



Larry Hogan, Governor
Boyd Rutherford, Lt. Governor
Mark Belton, Secretary
Joanne Throwe, Deputy Secretary

Quality Assurance Project Plan

for the
Maryland Department of Natural Resources
Chesapeake Bay
Water Quality Monitoring Program-
Chemical and Physical Properties Component
for the period July 1, 2017 - June 30, 2018

May 31, 2017

Tawes State Office Building • 580 Taylor Avenue • Annapolis, Maryland 21401
410.260.8DNR or toll free in Maryland 877.620.8DNR • TTY users call via Maryland Relay

**Quality Assurance Project Plan
for the
Maryland Department of Natural Resources
Chesapeake Bay Water Quality Monitoring Program -
Chemical and Physical Properties Component
for the period July 1, 2017 - June 30, 2018**

Prepared by:
Ben Cole and Thomas Parham
Tidewater Ecosystem Assessment
Maryland Department of Natural Resources
Tawes Building, D-2
580 Taylor Avenue
Annapolis, MD 21401

Website Address:
www.dnr.maryland.gov

Toll Free in Maryland:
1-877-620-8DNR, ext: 8630
Out of state call: 410-260-8630
TTY users call via the MD Relay:
711 (within MD)
Out of state call: 1-800-735-2258

© 2017 Maryland Department of Natural Resources

The facilities and services of the Maryland Department of Natural Resources are available to all without regard to race, color, religion, sex, sexual orientation, age, national origin or physical or mental disability. This document is available in alternative format upon request from a qualified individual.

Larry Hogan, Governor

Boyd Rutherford, Lt. Governor



Printed on Recycled Paper

**Quality Assurance Project Plan
for the
Maryland Department of Natural Resources
Chesapeake Bay
Water Quality Monitoring Program—
Chemical and Physical Properties Component
for the period July 1, 2017 - June 30, 2018**

May 31, 2017

Jerome Frank, Manager Nutrient Analytical Services Laboratory
Chesapeake Biological Laboratory
University of Maryland, Center for Environmental Science

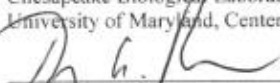
Thomas Parham, Principal Investigator
Director, Tidewater Ecosystem Assessment Division
Maryland Department of Natural Resources

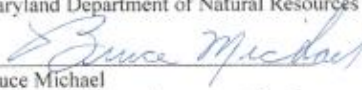
Bruce Michael
Director, Resource Assessment Services
Maryland Department of Natural Resources

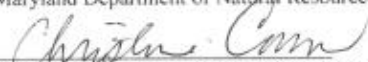
Christine Conn, Ph.D., Quality Assurance Officer
Director, Office of Science and Stewardship
Maryland Department of Natural Resources

James Hargett, Project Officer
Chesapeake Bay Program Office
U.S. Environmental Protection Agency

Richard Batiuk, Quality Assurance Officer
Chesapeake Bay Program Office
U.S. Environmental Protection Agency

PREFACE

This document is intended to describe in detail the activities conducted under the Chemical and Physical Properties Component of the Maryland Department of Natural Resources Chesapeake Bay Water Quality Monitoring Program. This is a coordinated program consisting of several components conducted in a similar manner for identical purposes in both the tributaries and mainstem of Maryland's Chesapeake Bay. This program is funded through the Maryland Department of Natural Resources and the U.S. Environmental Protection Agency.

DRAFT

LIST OF PREPARERS

Editors:

Ben Cole, Natural Resource Biologist, Tidewater Ecosystem Assessment, Resource Assessment Service, Maryland Department of Natural Resources, 580 Taylor Avenue, D-2, Annapolis, Maryland 21401.

Thomas Parham, Director, Tidewater Ecosystem Assessment, Maryland Department of Natural Resources, 580 Taylor Avenue, D-2, Annapolis, Maryland 21401.

Contributors:

Rebecca Burrell, Tidewater Ecosystem Assessment, Resource Assessment Service, Maryland Department of Natural Resources, 580 Taylor Avenue, D-2, Annapolis, Maryland 21401

Diana Domotor, Tidewater Ecosystem Assessment, Resource Assessment Service, Maryland Department of Natural Resources, 580 Taylor Avenue, D-2, Annapolis, Maryland 21401.

Laura Fabian, Resource Assessment Service, Maryland Department of Natural Resources, 1919 Lincoln Drive, Annapolis, Maryland 21401.

Jerry Frank, Manager, Nutrient Analytical Services Laboratory, Chesapeake Biological Laboratory, University of Maryland, Center for Environmental Science, Solomons, Maryland, 20688-0038.

Greg Gruber, Resource Assessment Service, Maryland Department of Natural Resources, 1919 Lincoln Drive, Annapolis, Maryland 21401.

Kristen Heyer, Manager, Water Quality Monitoring, Resource Assessment Service, Maryland Department of Natural Resources, 1919 Lincoln Drive, Annapolis, Maryland 21401.

Renee Karrh, Tidewater Ecosystem Assessment, Resource Assessment Service, Maryland Department of Natural Resources, 580 Taylor Avenue, D-2, Annapolis, Maryland 21401.

Nancy Kaumeyer, Chesapeake Biological Laboratory, University of Maryland, Center for Environmental Science, Solomons, Maryland, 20688-0038.

Deborah McKay, Resource Assessment Service, Maryland Department of Natural Resources, 1919 Lincoln Drive, Annapolis, Maryland 21401.

Brian Smith, Tidewater Ecosystem Assessment, Resource Assessment Service, Maryland Department of Natural Resources, 580 Taylor Avenue, D-2, Annapolis, Maryland 21401.

TABLE OF CONTENTS

PREFACE	iv
LIST OF PREPARERS	v
LIST OF FIGURES	vii
LIST OF TABLES	vii
ACRONYMS AND ABBREVIATIONS	viii
1. INTRODUCTION	2
2. MEASURED PARAMETERS	15
3. FIELD MEASUREMENTS AND SAMPLING	23
4. LABORATORY ANALYSIS	24
5. DATA MANAGEMENT, VERIFICATION AND DOCUMENTATION	24
6. PROJECT QUALITY ASSURANCE/QUALITY CONTROL	29
7. DATA ANALYSIS AND REPORTING	31
8. PROJECT ORGANIZATION AND RESPONSIBILITY	33
9. PROCEDURAL CHANGE PROTOCOL	34
10. LOG OF SIGNIFICANT CHANGES	34
11. REFERENCES	35

APPENDICES

Appendix I.	Water Column Sampling and Sample Processing Procedures
Appendix II.	Field, Laboratory, and Chlorophyll Sheets, Documentation and Procedures
Appendix III.	Cross Reference Sheet, Documentation and Procedures
Appendix IV.	Cruise Report/Quarterly Progress Report, Documentation and Procedures
Appendix V.	Field Instrument Quality Assurance/Quality Control (Includes Equipment Calibration Log and Instrument Maintenance/Repair Log)
Appendix VI.	Field Procedures Quality Assurance/Quality Control
Appendix VII.	University of Maryland, Chesapeake Biological Laboratory Nutrient Analytical Services Laboratory Standard Operating Procedures and Methods
Appendix VIII.	Split Sample Program and Split Sample Custody Log
Appendix IX.	Data Status Form, Documentation and Procedures
Appendix X.	Codes for Water Quality Sheets
Appendix XI.	Data Entry Request Form, Documentation and Procedures
Appendix XII.	Sample Verification Reports and Plots and Edit Form

Appendix XIII	Chesapeake Bay Monitoring Program Procedure Modification Tracking Form
Appendix XIV	Chesapeake Bay Monitoring Program Log of Significant Changes

LIST OF FIGURES

Figure 1	Map of Maryland Department of Natural Resources Chesapeake Bay Mainstem and Bay Tributary Water Quality Monitoring Stations.	6
Figure 2	Data Management Flow Chart.....	27
Figure 3	Data Tracking Flow Chart.....	28

LIST OF TABLES

Table 1	Mainstem and Tributary sample locations and descriptions.....	7
Table 2	NASL methods.....	16
Table 3	Water Column Parameters, Detection Limits, Methods References, Holding Times and Conditions.	18
Table 4	Minimum Detection Limits for Field Measurements	31

ACRONYMS AND ABBREVIATIONS

AA - autoanalyzer
Ag - silver
AgCl - silver chloride
AP - above pycnocline
ARS - Analysis Request Sheet
Au - gold
B - bottom sample
BP - below pycnocline OR barometric pressure
C - carbon
CBP - EPA's Chesapeake Bay Program
CBPO - EPA's Chesapeake Bay Program Office
CBL - University of Maryland's Chesapeake Biological Laboratory
CIMS - Chesapeake Information Management System
cm - centimeter
CMC - chlorophyll measurement computer
CSSP - Coordinated Split Sample Program
DHMH - Maryland Department of Health and Mental Hygiene
DAWG - Data Analysis Workgroup
DI - de-ionized
DIWG - Data Integrity Workgroup (a Chesapeake Bay Program workgroup, formerly AMQAW - Analytical Methods and Quality Assurance Workgroup)
DL - Detection Limit
DNR - Maryland Department of Natural Resources
DO - dissolved oxygen
DOC - dissolved organic carbon
EPA - U.S. Environmental Protection Agency
g - gram
H₂O - dihydrogen oxide (water)
H₂S - hydrogen sulfide
HCL - hydrochloric acid
ITAT - Integrated Trends Analysis Team
Hg - mercury
L - liter
LDO - Luminescent Dissolved Oxygen
m - meter
MASC - Chesapeake Bay Program Monitoring and Analysis Subcommittee
MDE - Maryland Department of the Environment
MDL - Minimum Detection Limit
MgCO₃ - magnesium carbonate
min. - minute
mg - milligram
ml - milliliter
mm - millimeter
N - nitrogen
NaHCO₃ - sodium bicarbonate

NASL - Chesapeake Biological Laboratory, Nutrient Analytical Services Laboratory
NIST - National Institute of Standards and Technology
nm - nanometer
no. - number
NO₂ - nitrite
NO₃ - nitrate
NPS - National Park Service
NTU - Nephelometric Turbidity Units
OD - optical density
P - phosphorus
PAR - Photosynthetic Active Radiation
PC - particulate carbon
PC - personal computer
PIP - Particulate Inorganic Phosphorus
PN - particulate nitrogen
PO₄ - phosphate
PP - particulate phosphorus
ppt - parts per thousand
QAO - Quality Assurance Officer (unless otherwise noted, this refers to the DNR QAO)
QAPP - Quality Assurance Project Plan
ROX - YSI 6150 Reliable Oxygen Sensor
RP - replicate
R/V - research vessel
S - surface sample
SAS - Statistic Analysis System
STAR - Scientific, Technical Assessment & Reporting
SIF - silica
Si - Dissolved Silicate
SOP - Standard Operating Procedure
TMAW - Tidal Monitoring and Analysis Workgroup
TDN - total dissolved nitrogen
TDP - total dissolved phosphorus
TPP - Total Particulate Phosphorus
trib - Bay Tributary
TSS - total suspended solids
TVS - Total Volatile Solids
USDI - U.S. Department of the Interior
USGS - U.S. Geological Survey
µg - Microgram
VSS - Volatile Suspended Solids
YSI - Yellow Springs Instruments

°C - degrees Celsius

1. INTRODUCTION

1.1 Background

At the completion of the U.S. Environmental Protection Agency's (EPA's) \$27 million study of Chesapeake Bay, the Agency published a document entitled *Chesapeake Bay: A Framework for Action* (EPA 1983). This report strongly recommended a long-term water quality monitoring program to serve the Bay's management community by accurately describing the current state of the Bay mainstem and tidal tributaries (baseline or 'status') and detecting long-term changes (trends) resulting from human activities. Management strategies at that time were hindered by the lack of precise information about the Bay and its response to increasing or decreasing pollution.

Managers, scientists, and statisticians recognized that to establish baseline conditions and then begin to identify trends would require a multi-year effort on the order of a decade or more. Long-term data was needed to overcome the natural year-to-year variability that can obscure changes due to human activities. As the EPA study drew to a close, scientists and managers convened in workshops to formulate plans on several topics, including water quality monitoring. The monitoring workshop recommendations for chemical and physical measurements were published in the appendices of *Chesapeake Bay: A Framework for Action*. The appendices described the chemical/physical monitoring plan in terms of station locations, parameters to be measured, and sampling frequency.

This Quality Assurance Project Plan (QAPP) describes Maryland's implementation of the coordinated Maryland, Virginia, and EPA Chesapeake Bay monitoring program as outlined in *Chesapeake Bay: A Framework for Action* (EPA 1983). This part of Maryland's Chesapeake Bay Water Quality Monitoring Program is known as the "Chemical and Physical Properties Component" and covers monitoring in the Maryland portion of the mainstem as well as the tidal tributaries. Other components of the water quality program measure biological and process oriented indicators of water quality; those components are not described in this document.

1.2 Objectives

The Maryland Department of Natural Resources (DNR) uses the data generated by means of the procedures in this QAPP to meet the five water quality monitoring objectives of the Chesapeake Bay Water Quality Monitoring Program:

1. Characterize the present state of the Bay mainstem and its tributaries, including spatial and seasonal variation, using key water quality indicators.
2. Determine long-term trends or changes in key water quality indicators in relation to pollution control programs.
3. Integrate the information collected in all components of the monitoring program to gain a more comprehensive understanding of water quality processes and the relationship between water quality and living resources.

4. Track the progress of management strategies to reduce nutrient pollution.
5. Provide data for the Chesapeake Bay watershed and ecological models.

1.3 Sampling Design and Data Quality Objectives

1.3.1 *Parameters*

The scope of work for this component of the coordinated Chesapeake Bay Water Quality Monitoring Program includes the measurement of chemical and physical parameters in the water column. Parameters such as nutrients, total suspended solids, chlorophyll *a*, dissolved oxygen and water clarity were selected to (1) provide information on eutrophication trends; (2) calibrate Bay water quality models; and, (3) correlate living resources data to water quality data. Other parameters such as salinity and temperature are necessary to provide a more rigorous interpretation of these key water quality indicators. The same parameters are collected in the mainstem, large tributaries (Potomac and Patuxent Rivers), and minor tributaries except for dissolved organic carbon and silica.

Dissolved organic carbon sample collection during mainstem cruises was discontinued from 1996-2016. Beginning in May 2017, DOC sampling resumed at stations CB1.1, CB1.2, CB3.3C, CB4.3 and CB5.2. Mainstem DOC samples will be collected from March through September only.

Silica (SIF) samples will be collected monthly, from the surface and above pycnocline layers, January through June 2018 at the plankton sampling stations (CB1.1, CB2.2, CB3.3C, CB4.3C, CB5.2, TF2.3, RET2.2, TF1.5, LE1.1, ET5.1 and WT5.1). Silica samples will not be collected at any mainstem or tributary stations July through December 2017.

Nutrient samples will not be collected during the second mainstem cruises in July 2017. Nutrient samples will be collected during the second mainstem cruises in August 2017 and June 2018.

(A complete list of parameters measured and detection limits is provided in Section 2, Table 3.)

The information gained from analyzing the entire suite of parameters allows managers to determine whether or not water quality goals established for living resources have been met and aids managers in establishing programs to control point and non-point sources of pollutants to the Bay.

1.3.2 *Spatial Aspects*

A total of 22 mainstem stations and 60 tributary stations are included in Maryland's Chemical and Physical Properties Component of the Chesapeake Bay Water Quality Monitoring Program (Figure 1 and Table 1). Station locations were selected to provide data that would satisfy the five objectives of the program stated above for the major tributaries and the mainstem. The following describes the four sets of criteria used to determine the general location for stations:

Primary Selection Criteria. During the initial phases of the Bay Program, EPA developed a segmentation/characterization scheme of the Chesapeake Bay and its tributaries published in the appendices

of *Chesapeake Bay: A Profile of Environmental Change* (EPA 1983). This scheme provided guidance for station selection by delimiting different regions (based on circulation, salinity, and geomorphology) such as tidal fresh, oligohaline, and mesohaline. Several primary goals were considered in selecting station locations. Selecting a suite of stations such that each segment would be characterized was the foremost goal. Another important criterion was the location of boundaries between segments (e.g. mouths of major tributaries and the upper boundary of the deep trough region). Boundary areas are important because of their influence on a particular region of the Bay or their relevance to problem areas. In large systems, i.e., the Potomac and Patuxent Rivers and the mainstem, multiple stations were located in some of the major salinity zones due to the large size of these systems and their importance to management concerns. Existing water quality monitoring stations in the Potomac River and Patuxent River were incorporated into the Bay-wide network because of the wealth of historical data at these stations.

Secondary Selection Criteria. Locations of documented water quality problems in certain areas served as secondary considerations in locating stations. For example, additional stations were included in the lateral dimension of the deep trough region of the mainstem to characterize the deepwater anoxic/hypoxic conditions. Another example was the siting of stations in some of the smaller tributary segments in areas that were profoundly impacted by point sources. Stations sited in these affected areas provide excellent opportunities to assess the effectiveness of control strategies targeted at reducing these major impacts.

Tertiary Selection Criteria. Another consideration in siting stations was their proximity to important living resource habitats and living resource monitoring sites. This criterion was accommodated only if the primary and secondary criteria above were also satisfied. These stations provide valuable data to correlate with living resources monitoring and thereby help to resolve the link between water quality and fluctuations in living resources.

Final Selection Criteria. The fourth and final consideration in locating stations was the historical record of water quality sampling. If a station already had a record of previous water quality data *and* it satisfied the three sets of criteria stated above, the station was adopted for this program to permit comparisons with historical databases. In selecting stations for the Patuxent and Potomac Rivers, this criterion was elevated to a primary criterion. Additional historical stations in the Patuxent and Potomac were adopted into the Chesapeake Bay Program sampling program even if they did not fulfill all three sets of criteria above, because of the very long-term data sets associated with these stations.

Establishing Mid-Channel and Near-shore Stations. In both the mainstem and tributaries, stations were selected in mid-channel locations to provide a characterization of the entire water column in that region and to capture the lowered oxygen levels in the deeper layers. The water column at mid-channel also provides a more stable environment than shallow locations, which are subject to ephemeral influences such as wind-driven resuspension of bottom sediments and periodic advection of deep-channel water masses; thus, mid-channel stations provide data with less short-term variability. Minimizing short-term variability is desirable in order to detect long-term trends. As mentioned above, in the mainstem's deep trough region, lateral stations were established to track a particular concern. Two near-shore stations were located beside each of the four mid-channel stations. These near-shore stations were located at the 30-foot depth contour or at the boundary of adjacent embayments. Stations also were located at the boundary between the mainstem and the two largest tributaries in Maryland—the Susquehanna and Potomac Rivers—to assess the water quality interactions occurring across these critical regions.

Updating the Segmentation Scheme. During 1997, a workgroup was established to re-evaluate the segmentation scheme using the data generated by the program from 1985-1996. DNR uses the current

segmentation scheme established by the EPA Chesapeake Bay Program (CBP) to classify stations and analyze data (see Table 1). Under the new segmentation scheme, four segments (CHOTF, NANO, HNGMH, and POCOH) do not include long-term stations. The *Chesapeake Bay Program, Analytical Segmentation Scheme, Revisions, Decisions and Rationales, 1983-2003, 2005 Addendum*, December, 2005 and the Chesapeake Bay Program Monitoring and Analysis Subcommittee Tidal Monitoring and Analysis Workgroup, October 2004 document: *Chesapeake Bay Program, Analytical Segmentation Scheme, Revisions, Decisions and Rationales 1983-2003* provide detailed descriptions of the CBP's segmentation and its development. *Ambient Water Quality Criteria for Dissolved Oxygen, Water Clarity and Chlorophyll a for the Chesapeake Bay and Its Tidal Tributaries, 2008 Technical Support for Criteria Assessment Protocols Addendum* summarizes previous segmentation work and documents recommended refinements of the segmentation scheme to address dissolved oxygen and water clarity assessment issues.

1.3.3 *Temporal Aspects*

Water column samples are collected at least once a month at most stations, for a minimum of twelve samplings per year. In the Chesapeake mainstem, sampling will be conducted twice monthly in July and August of 2017 and June of 2018, and once monthly during the remaining months, for a total of fifteen samplings in the period of July 1, 2017 - June 30, 2018. Sampling during the second July 2017 surveys will be comprised of water-column profiles only. Eastern and western transect mainstem station samples will not be collected from November through February, resulting in only eleven samplings a year. On the Potomac and Patuxent and smaller tributaries, twelve samplings will be conducted per year. See Appendix XIV, Log of Significant Changes, for details. Sampling frequency for each station is shown in Table 1. This frequency of sampling permits assessments to be made on a seasonal basis, which is a time scale consistent with many of the natural intra-annual changes in water quality indicators.

Because of the relatively small sample sizes resulting from only two to four sampling events per season, it is more difficult to detect seasonal trends in data from stations sampled only once per month. Nevertheless, with a long-term program, sufficient data can be collected to determine seasonal patterns in most water quality parameters at each site with high statistical confidence.

At its inception in 1984, the Chesapeake Bay monitoring program included 20 cruises each year in the mainstem, Patuxent, Potomac, and smaller tributaries. In 1994, *An Assessment of the Power and Robustness of the Chesapeake Bay Program Water Quality Monitoring Program: Phase II - Refinement Evaluations* (Alden et al. 1994) concluded that although the 12-cruise scenario was less statistically powerful than the 20-cruise scenario, the 12-cruise scenario was adequate for the Chesapeake Bay mainstem monitoring to capture long-term annual trends; the Chesapeake Bay Program decided on a 14-cruise scenario for the monitoring program. Based on these recommendations, in January 1996, Maryland dropped its Chesapeake Bay mainstem January and February cruises and reduced its cruises in March, June, September, and October to once per month. Experience has since shown that this reduced sampling frequency can miss some extremely important climatic and biological events (e.g., the 100-year flood of January 1996). Therefore, CBP restored funding in Maryland for its January and February monitoring cruises beginning in January 1999, for a total of 16 cruises. When funding was available, a second June mainstem cruise was also added to the sample schedule to better characterize the onset of summer hypoxia/anoxia conditions in deep water.

In November 2009, EPA funding reductions resulted in a resumption of a fifteen-cruise scenario. The mainstem was sampled monthly and there are second cruises in June, July and August. Vertical profiles were executed but nutrient samples were not always collected on the second cruises.

Beginning in January 2010, due to further funding reductions, the number of times samples were collected at all stations in embayments, large tributaries, smaller tributaries, C&D Canal and Tangier Sound were reduced from previous levels to twelve times per year.

Due to funding cutbacks sample collection ended at nine tributary stations in December 2013, Chicamacomico River: CCM0069; Manokin River: BXK0031, MNK0146; Nanticoke River: XDJ9007; Pocomoke River: POK0087, XAK7810; Transquaking River: TRQ0088, TRQ0146; and Wicomico River: XCI4078.

This level of sampling frequency is judged to be the optimal allocation of effort given the limited level of resources. It provides for wide spatial coverage of almost every major tributary in Maryland as well as for information on the major systems that are the focus of major management strategies.

Figure 1. Map of Maryland Department of Natural Resources Chesapeake Bay Mainstem and Bay Tributary Water Quality Monitoring Stations. Red squares indicate the stations monitored since 1985 (or earlier).

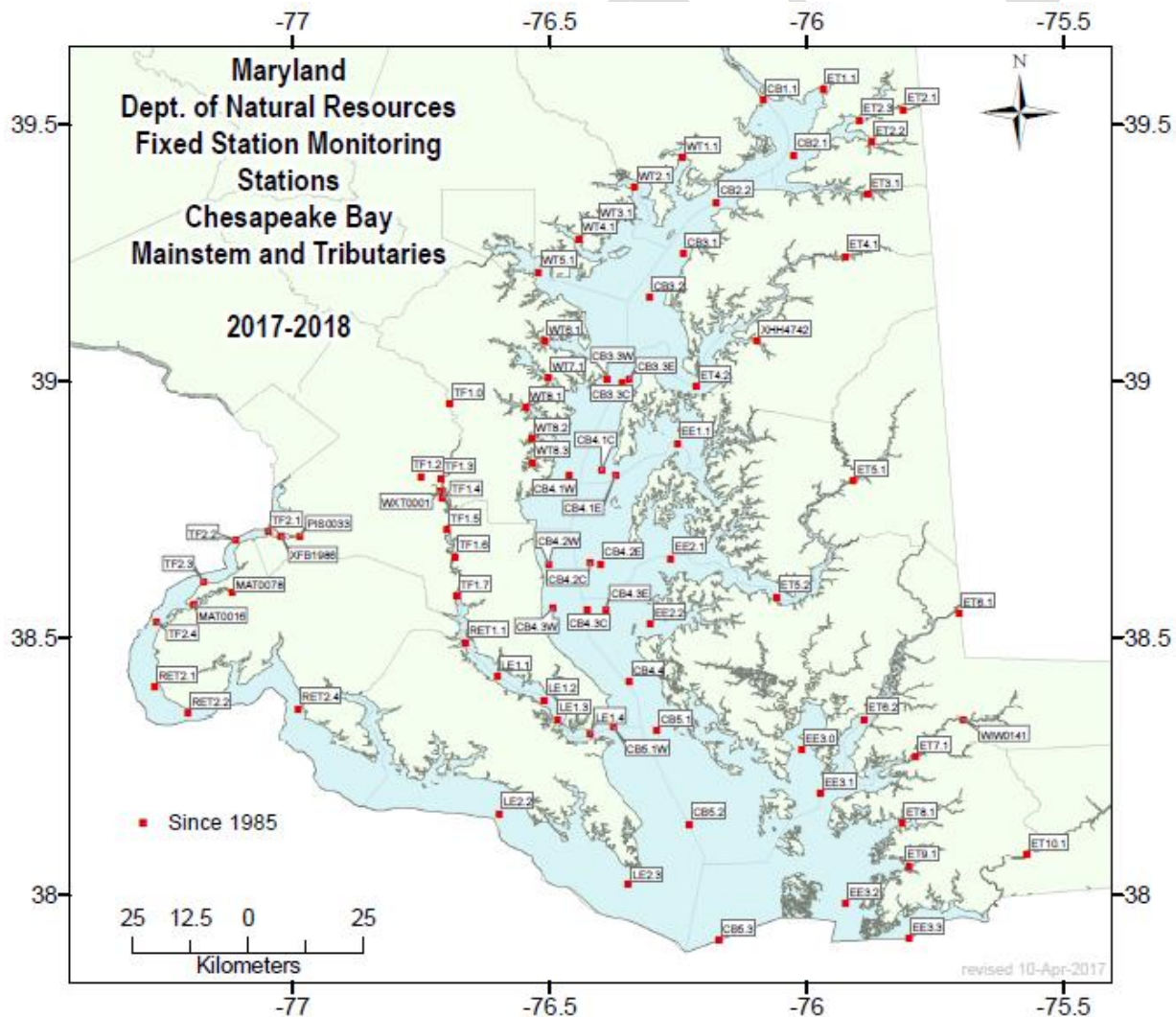

Table 1. Mainstem and Tributary sample locations and descriptions

Station	Longitude	Latitude	Component	Ches. Bay Program Segment	Location/Depth	Sampling Coordination	Historical Station names	Annual Sample Freq. x No. Of Depths
CB1.1	-76.084808	39.54794	Mainstem	CBTF1	Mouth of Susquehanna River (700 yds from abandoned Light House on Hdg 040, 400 yds NNW of N 18 on line with N 20); 5.7 m	PAR, VSS, plankton Mar - Nov whole water column composite live & fixed, DOC Mar-Sep	OEP XKH3147	15x2 14 sampling trips + 1 readings only
CB2.1	-76.025993	39.44149	Mainstem	CBTF1	SW of Turkey Point (1 nm from Turkey Pt Light on Hdg 240, 800 yds SE of RG A); 6.1m	PAR	CBI 927SS; OEP XJH6680	15x2 14 sampling trips + 1 readings only
CB2.2	-76.175789	39.34873	Mainstem	CB2OH	W of Still Pond (500 yds W of G 49, 1.75 nm S of Taylor Island Pt off Still Pond); 11.5m	PAR, VSS, plankton Mar - Nov whole water column composite live & fixed: Jul-Sep-whole water column composite picoplankton, DOC Mar-Sep	CBI 92OU, 921W, 922Y; OEP XJG0999	15x4 14 sampling trips + 1 readings only
CB3.1	-76.240501	39.2495	Mainstem	CB2OH	SE of Gunpowder Neck (2.1nm from south tip of Poole's Island Hdg 146, halfway between buoys 31 and 33); 11.2 m.	PAR	CBI 913R, 914S	15x4 14 sampling trips + 1 readings only
CB3.2	-76.306313	39.16369	Mainstem	CB3MH	NW of Swan Pt (400 yds NW of Tolchester Channel 13, 1.9 nm from Swam Point on Hdg 328); 11.5 m	PAR	CBI 909; OEP XHG4953, XHG9915	15x4 14 sampling trips + 1 readings only
CB3.3C	-76.359673	38.99596	Mainstem	CB3MH	N of Bay Bridge (1.6 nm, from Sandy Pt Light on Hdg 145, 0.4 nm NNE of bridge at edge of cable cross); 20.7 m.	PAR, VSS, DNR plankton Jan-Dec- Above pycnocline composite-live & fixed. Jul-Sep-above pycnocline composite picoplankton, DOC Mar-Sep	CBI 858C, 859B; OEP XFH1373, XGF9784; EPA D2	15x4 14 sampling trips + 1 readings only
CB3.3E	-76.345169	39.00412	Mainstem	CB3MH	NE of Bay Bridge (1.9nm from Sandy Pt Light on Hdg 260, 1 nm NNE of Bridge in East Channel); 8.2 m	PAR	CBI 859A; OEP XFH0293; EPA D3	11x2 Mar-Oct 10 sampling trips +1 readings only
CB3.3W	-76.3881	39.00462	Mainstem	CB3MH	NW of Bay Bridge (0.7 nm from Sandy Pt Light on Hdg 210, 0.7 nm SE Sandy Pt Water Tank); 9.1m.	PAR	CBI 859D; OEP XHF0366; EPA D1	11x2 Mar-Oct 10 sampling trips +1 readings only

Station	Longitude	Latitude	Component	Ches. Bay Program Segment	Location/Depth	Sampling Coordination	Historical Station names	Annual Sample Freq. x No. Of Depths
CB4.1C	-76.399452	38.82593	Mainstem	CM4MH	SW of Kent Pt (0.5nm from Bloody Pt Light just West of line from Bloody Pt to G 83); 31.0 m	PAR	CBI 845G, 848E; OEP XFF9178; EPA '83DO	15x4 14 sampling trips + 1 readings only
CB4.1E	-76.371437	38.81809	Mainstem	CB4MH	S of Kent Pt (1.4 nm SE Bloody Pt Light, 300 yds SW buoy 1 for Eastern Bay); 23.7 m	PAR	CBI 851N; EPA '83DO; OEP XFF9178	11x4 Mar- Oct 10 sampling trips +1 readings only
CB4.1W	-76.462715	38.81498	Mainstem	CB4MH	SE of Horseshoe Pt (3.5nm from Bloody Pt. Light on Hdg 260, 1.6 nm E of Franklin Manor); 9.1 m	PAR	CBI 848G, H, I; OEP XFF1844, XFF8922	11x2 Mar-Oct 10 sampling trips +1 readings only
CB4.2C	-76.421265	38.64618	Mainstem	CB4MH	SW of Tilghman Island (2nm from Sharps Island Light on Hdg 290, 300 yds NE of CR buoy) 26.2 m.	PAR	EPA '83DO; OEP XEF8648	15x4 14 sampling trips + 1 readings only
CB4.2E	-76.401314	38.64499	Mainstem	CB4MH	SW of Tilghman Island (1.3nm from Sharps Island Light on Hdg 305, 0.9 nm E of CR buoy); 9.1 m	PAR	OEP XEF8859	11x2 Mar-Oct 10 sampling trips +1 readings only
CB4.2W	-76.502167	38.64354	Mainstem	CB4MH	NW of Plum Pt (6nm from Sharps Island. Light on Hdg 280, 1.0 nm E of Camp Roosevelt); 9.1 m	PAR	OEP XEF8699; EPA '83DO	11x2 Mar-Oct 10 sampling trips +1 readings only
CB4.3C	-76.42794	38.55505	Mainstem	CB4MH	E of Dares Beach (0.5 nm W of R 78, 5.7 nm from Sharps Island Light, Hdg 220); 25.6 m.	PAR, VSS, plankton Mar-Nov-Above pycnocline composite-live & fixed. Jul-Sep-above pycnocline composite picoplankton, DOC Mar-Sep	OEP XEF3343	15x4 14 sampling trips + 1 readings only
CB4.3E	-76.391212	38.55624	Mainstem	CB4MH	Mouth of Choptank River (1.7 nm. East of R78, 5 nm. from Sharps Island Light on Hdg 195); 21.6 m	PAR	OEP XEF3465	11x4 Mar-Oct 10 sampling trips +1 readings only
CB4.3W	-76.494019	38.55728	Mainstem	CB4MH	E of Dares Beach (1nm. East of Dares Beach, 3nm. West of R78); 9.7 m	PAR	CBI 834H, J; OEP XEF3405	11x2 Mar-Oct 10 sampling trips +1 readings only

Station	Longitude	Latitude	Component	Ches. Bay Program Segment	Location/Depth	Sampling Coordination	Historical Station names	Annual Sample Freq. x No. Of Depths
CB4.4	-76.34565	38.41457	Mainstem	CB4MH	NE of Cove Pt (2.4 nm from Cove Pt on Hdg 055); 28.6 m	PAR, Quarterly Split Sample Location	OEP XDF4693	15x4 14 sampling trips + 1 readings only
CB5.1	-76.292145	38.3187	Mainstem	CB5MH	E of Cedar Pt (1 nm. ENE of mid-channel buoy HI, 4nm. from Cedar Pt. on Hdg 070); 33.2 m	PAR	CBI 818N, 818P, 819N, 819O; OEP XCG9223	15x4 14 sampling trips + 1 readings only
CB5.2	-76.227867	38.13705	Mainstem	CB5MH	Mid Bay E of Pt No Point (3 nm. From Point No Point Light on Hdg 080); 29.0 m	PAR, VSS, plankton Jan-Dec-Above pycnocline composite-live & fixed. Jul-Sep-above pycnocline composite picoplankton, DOC Mar-Sep	Benthos #58 (Versar); OEP XBG8262	15x4 14 sampling trips + 1 readings only
CB5.3	-76.171371	37.91011	Mainstem	CB5MH	NE of Smith Point (2nm. from Smith Point Light toward on Hdg 020, intersect MD/VA line and transect from Smith Pt to Holland bar Light); 25.3 m	PAR	USGS 37524807, 6094200; OEP XAG4699	15x4 14 sampling trips + 1 readings only
TF1.0	-76.694107	38.95557	Patuxent	PAXTF	At bridge on US Rt. 50 (upstream side of bridge; USGS Gage No 59440); 3 m		OEP PXT0603; USGS 01594440; EPA E	12x1
TF1.2	-76.75087	38.8143	Patuxent	WBRTF	Midstream of Western Branch at Water Street crossing in Upper Marlboro, MD; 3 m		OEP WXT0045	12x1
WXT0001	-76.713432	38.78539	Patuxent	WBRTF	Western Brach from pier at Mt Calvert House in Upper Marlboro, 0.1 miles above mouth; 1.0 m			12x1
TF1.3	-76.712273	38.81092	Patuxent	PAXTF	Mid-channel from MD Rt. 4 bridge near Wayson's Corner; 3.7 m		OEP PXT0494; EPA E5, 5	12x1
TF1.4	-76.709267	38.77302	Patuxent	PAXTF	West Shore from main pier at Jackson Landing; just below confluence with Western Branch; 3.0 m		OEP PXT0456; EPA E6A	12x1
TF1.5	-76.701462	38.71012	Patuxent	PAXTF	Mid-channel at Nottingham, 11.1m	PAR, VSS, plankton Mar-Nov whole water column composite live and fixed, DOC Mar-Sep	OEP PXT0402; EPA E8	12x4
TF1.6	-76.683815	38.65845	Patuxent	PAXOH	Mid-channel off the wharf at Lower Marlboro, 6 m.	PAR	OEP XED9490; EPA E9; J.H. 5945	12x3

Station	Longitude	Latitude	Component	Ches. Bay Program Segment	Location/Depth	Sampling Coordination	Historical Station names	Annual Sample Freq. x No. Of Depth
TF1.7	-76.681007	38.58211	Patuxent	PAXOH	Mid-channel on a transect heading of approx. 115 degrees from Jack's Creek; 3.1 m	PAR, VSS	OEP XED4892; J.H. 5946	12x2
RET1.1	-76.664291	38.4909	Patuxent	PAXMH	Mid channel, 0.5 km ENE of Long Point, 11.1 m	PAR	OEP XDE9401; EPA E14, 4, CB 1	12x4
LE1.1	-76.601761	38.42535	Patuxent	PAXMH	Mid-channel SSW of Jack Bay sand-spit. NE of Sandgates; 12.5	PAR, VSS, Jan-Dec above the pycnocline live and fixed composite plankton sample; July-September a fixed picoplankton sample from the above pycnocline composite, DOC Mar-Sep	OEP XDE5339; EPA E15	12x4
LE1.2	-76.511322	38.37887	Patuxent	PAXMH	Mid-channel, 1.6 km SW of Petersons Pt.; 17.8 m	PAR	OEP XDE2792	12x4
LE1.3	-76.484901	38.3398	Patuxent	PAXMH	Mid-channel 1200 m due N of Pt. Patience, ESE of Half Pone Pt; 23.1 m	PAR, Mar-Nov Live plankton collected from the surface	OEP XDF0407	12x4
LE1.4	-76.421509	38.312	Patuxent	PAXMH	Mid-channel on a transect between Drum Pt. and Fishing Pt; 16.5m	PAR	OEP XCF8747	12x4
CB5.1W	-76.37574	38.32522	Patuxent	PAXMH	Mid-channel on a transect between Cedar Pt and Cove Pt; 8.9m	PAR	OEP XCF9575	12x4
PIS0033	-76.986732	38.69842	Potomac	PISTF	Piscataway Creek at Maryland Rt 210 crossing; 1 m	Sampled in coordination with mainstem		12x1
XFB1986	-77.02317	38.69787	Potomac	PISTF	Piscataway Creek off Ft. Washington Marina between DM4 and DM6, SW of dredged channel; 2m	Sampled in coordination with mainstem, plankton Mar-Nov live surface		12x1
MAT0078	-77.118645	38.58852	Potomac	MATTF	Mattawoman Creek at MD. Rt 225 crossing; 1 m	Sampled in coordination with mainstem		12x1
MAT0016	-77.193451	38.56508	Potomac	MATTF	Mattawoman Creek at green day beacon 5 off Sweden Pt; 2 m	Sampled in coordination with mainstem, plankton Mar-Nov live surface	OEP XEA3687	12x1
TF2.1	-77.048759	38.70664	Potomac	POTTF	At Fl buoy 77 off mouth of Piscataway Creek; 19 m	Sampled in coordination with mainstem, plankton Jul-Sep-live surface	OEP XFB2470; EPA – several	12x3

Station	Longitude	Latitude	Component	Ches. Bay Program Segment	Location/Depth	Sampling Coordination	Historical Station names	Annual Sample Freq. x No. Of Depth
TF2.2	-77.111107	38.69067	Potomac	POTTF	Buoy 67 off mouth of Dogue Creek; 8 m	Sampled in coordination with mainstem, plankton Jul-Sep-live surface	OEP XFB1433; USGS 3841360 77054600; EPA – Several	12x3
TF2.3	-77.173897	38.6082	Potomac	POTTF	Buoy N54 mid-channel off Indian Head; 15 m	Sampled in coordination with mainstem, VSS, plankton Mar-Nov whole water column composite live & fixed, DOC Mar-Sep	OEP XEA6596	12x3
TF2.4	-77.265404	38.5301	Potomac	POTTF	Buoy 44 between Possum Pt. And Moss Point; 9 m	Sampled in coordination with mainstem, plankton Jul-Sep-live surface	OEP XEA1840; USGS 06158710; EPA - Several	12x3
RET2.1	-77.269096	38.4035	Potomac	POTOH	Buoy 27 SW of Smith Point; 8 m	Sampled in coordination with mainstem	OEP XDA4238; EPA – Several	12x2
RET2.2	-77.205101	38.3525	Potomac	POTOH	Buoy 19 mid-channel off Maryland Point; 11 m	Sampled in coordination with mainstem, VSS, plankton Jan-Dec-whole water column composite live & fixed, DOC Mar-Sep	OEP XDA1177; EPA - Several	12x3
RET2.4	-76.990631	38.3626	Potomac	POTMH	Mid-channel at Morgantown bridge (US Rt. 301); 19 m	Sampled in coordination with mainstem, VSS, plankton Jan-Dec live surface	OEP XDC1706; USGS 01660800; EPA - Several	12x4
LE2.2	-76.598	38.1576	Potomac	POTMH	Potomac River off Ragged Point at Buoy 51B; 10 m	Sampled in coordination with mainstem, VSS, DOC Mar-Sep	OEP XBE9541	12x4
LE2.3	-76.347702	38.0215	Potomac	POTMH	Mouth of Potomac River (1.6 nm from Pt Lookout on Hdg 240, 0.5 nm NW of Whistle A); 19.8 m	Sampled on mainstem cruise	OEP XBF0893	14x4
ET1.1	-75.967819	39.56976	Tributary	NORTF	Northeast River at Daymarker 12 off Hance Pt, mid-channel; 3 m		OEP XKI4220, XKI3717, XKI4523, XKI5025	12x2
ET2.1	-75.811348	39.5293	Tributary	C&DOH	C&D Canal E of Rt 213 Bridge at Chesapeake City; 13 m		OEP XKJ1810, XKJ1811	12x2

Station	Longitude	Latitude	Component	Ches. Bay Program Segment	Location/Depth	Sampling Coordination	Historical Station names	Annual Sample Freq. x No. Of Depths
ET2.2	-75.87368	39.46704	Tributary	BOHOH	Bohemia River off Hack Pt, 75 yds ENE of daymarker R 4, mid-channel; 3 m		OEP XJI8076, XJI7678; EPA U9	12x2
ET2.3	-75.897827	39.50873	Tributary	ELKOH	Elk River SE of Old Cornfield Pt at G 21, mid-channel; 12 m		OEP XKI0661; EPA U10	12x2
ET3.1	-75.882034	39.36416	Tributary	SASOH	Sassafras R from end of pier at Georgetown Yacht Basin, NW side of MD. Rt. 213 bridge; 5 m		OEP XJI1970; EPA U1	12x2
ET4.1	-75.924896	39.2437	Tributary	CHSOH	Chester River at Rt 290 bridge near Crumpton; 6 m		OEP CHE0367	12x2
ET4.2	-76.215096	38.99233	Tributary	CHSMH	Lower Chester River South of Easter Neck Island 200 yds SW of buoy FL G 9; 16m	plankton Jan-Dec-above pycnocline composite; Jul-Sep-above pycnocline composite picoplankton, DOC Mar-Sep	OEP XGG9572; CBI CHO9C	12x4
EE1.1	-76.251503	38.88	Tributary	EASMH	Eastern Bay between Tilghman Pt and Parsons Island, N of buoy R4; 13m	Mar-Nov-live plankton at surface	OEP XGG2649; CBI 851N	12x4
ET5.1	-75.909706	38.80645	Tributary	CHOOH	Upper Choptank River 200 yds upriver from Ganey's Wharf, downstream of confluence with Tuckahoe Creek; 6 m	Mar-Nov-whole water column composite -live & fixed plankton	OEP CHO0429	12x2
ET5.2	-76.058701	38.5807	Tributary	CHOMH2	Lower Choptank River, mid-river 50yds NNE of G I, W of Rt 50 bridge at Cambridge; 11 m	Mar-Nov-above pycnocline composite-live & fixed. Jul-Sep-above pycnocline composite picoplankton, DOC Mar-Sep	OEP XEH4766	12x4
EE2.1	-76.264297	38.6549	Tributary	CHOMH1	Choptank embayment between Todd's Point and Nelson Pt; 8 m		OEP XEG9440, XEG9652	12x4
EE2.2	-76.304077	38.52609	Tributary	LCHMH	Little Choptank River mid-channel West of Ragged Point, W of Buoy FI g 3; 14 m		OEP XEG1617	12x2
EE3.0	-76.01033	38.28093	Tributary	FSBMH	Fishing Bay at daymarker 3, W of Roasting Ear Pt; 7 m	VSS, plankton Mar-Nov-live surface	OEP XCH6994, XCH5991	12x2
ET6.1	-75.703056	38.54833	Tributary	NANTF	Upper Nanticoke River at old Rt. 313 bridge (fishing pier, 1987) in Sharptown; 5 m	VSS, Mar-Nov-live surface plankton	OEP NAN0302 1	12x2

Station	Longitude	Latitude	Component	Ches. Bay Program Segment	Location/Depth	Sampling Coordination	Historical Station names	Annual Sample Freq. x No. Of Depths
ET6.2	-75.888336	38.34133	Tributary	NANMH	Lower Nanticoke River mid-channel near FI G 11; 3.5 m	VSS	Near OEP XDI0567, Near OEP XDI0567	12x2
EE3.1	-75.973206	38.19685	Tributary	TANMH	North Tangier Sound, NW of Haines Pt, 100 yds N of buoy R16; 13 m	Jan-Dec-above pycnocline composite plankton-live & fixed; Jul-Sep-above pycnocline picoplankton, DOC Mar-Sep	OEP XCI1717	12x4
WW0141	-75.695686	38.34156	Tributary	WICMH	Wicomico River at upper ferry crossing on Upper Ferry Road	DNA probe, Pfiesteria sampling 1998-2002		12x1
ET7.1	-75.787933	38.26783	Tributary	WICMH	Lower Wicomico River at Whitehaven, 150 yds downriver of Ferry Road, mid-channel; 7m	VSS, plankton Mar-Nov-live surface	OEP WIW0050	12x2
ET8.1	-75.81411	38.13794	Tributary	MANMH	Manokin River at upper extent of channel; approx. 100 yds NNE of buoy R 8, mid-channel; 6 m	VSS	OEP XBJ8215	12x2
ET9.1	-75.801666	38.055	Tributary	BIGMH	Big Annemessex River, NW of Long Pt in channel S of daymarker G5; 5m	VSS	OEP XBJ3312	12x2
EE3.2	-75.924232	37.98139	Tributary	TANMH	South Tangier Sound, mid-channel East of Smith Island, 500 yds NNW of buoy R8; 28 m	plankton Mar-Nov-live surface	OEP XAI8845, Near OEP XBI3003	12x4
EE3.3	-75.801483	37.91455	Tributary	POCMH	Pocomoke Sound, near buoy W S"A" midway between Oystershell Pt and Long Pt	Plankton Mar-Nov-live surface	Near OEP XAJ4719, Near VA EE3.1	12x2
WT1.1	-76.24205	39.43511	Tributary	BSHOH	Bush River E of Gum Point, E of FI G9 on power line support; 2 m		OEP XJG6254	12x2
WT2.1	-76.334648	39.37747	Tributary	GUNOH	Gunpowder River, 200 yds E of Oliver Point at buoy G15; 2.5 m		OEP XJF2798	12x2
WT3.1	-76.409538	39.30538	Tributary	MIDOH	Middle River East of Wilson Point at channel junction daymarker WP; 3 m	plankton Mar-Nov-live surface	OEP XIF5484; EPA M2	12x2
WT4.1	-76.44368	39.27755	Tributary	BACOH	Back River, East of Stansbury Point, East of daymarker R12; 2 m		OEP XIF6633, Near OEP XIF6732	12x2
WT4.1	-76.44368	39.27755	Tributary	BACOH	Back River, East of Stansbury Point, East of daymarker R12; 2 m		OEP XIF6633, Near OEP XIF6732	12x2

Station	Longitude	Latitude	Component	Ches. Bay Program Segment	Location/Depth	Sampling Coordination	Historical Station names	Annual Sample Freq. x No. Of Depths
WT5.1	-76.522537	39.21309	Tributary	PATMH	Patapsco River East of Hawkins Point at Buoy G3; 14 m	Plankton Mar-Nov-above pycnocline composite-live & fixed. Jul-Sep-above pycnocline composite picoplankton, DOC Mar-Sep	OEP XIE2885	12x4
WT6.1	-76.510048	39.07851	Tributary	MAGMH	Magothy River N of South Ferry Pt, mid-channel at buoy R12 and daymarker G11; 5 m	plankton Mar-Nov-live surface; Jul-Sep picoplankton at surface	OEP XHE4794	12x2
WT7.1	-76.503502	39.00764	Tributary	SEVMH	Severn River, 200 yds upstream of Rt 50/301 bridge and 150 yds off NE shore; 9 m	plankton Mar-Nov-live surface	OEP XHE0497	12x2
WT8.1	-76.546097	38.9496	Tributary	SOUMH	South River South of Poplar Point at daymarker R16; 9m	plankton Mar-Nov-live surface; Jul-Sep picoplankton at surface	OEP XGE6972	12x2
WT8.2	-76.534904	38.88696	Tributary	RHDMH	Rhode River between Flat Island and Big Island; 3 m		OEP XGE3279	12x2
WT8.3	-76.534103	38.8425	Tributary	WSTMH	West River just upstream of daymarker R6; 4 m		OEP XGE0579	12x2
XHH4742	-76.097198	39.07807	Tributary	CHSMH	Mid-Channel, 0.6 km ESE of Rocky Point; 4m./mid-channel, .8 km NW of Jacobs Nose			12x2

KEY FOR Historical Stations:

Abbreviation	Description
CBI	Chesapeake Bay Institute, Johns Hopkins University, 1949-1980
EPA/AFP	EPA, Annapolis Field Office studies, 1969-1970
EPA	EPA, Water Quality Office, Chesapeake Technical Support Laboratory, 1967-1969
USDI	U.S. Department of the Interior, Federal Water Pollution Control Administration, Chesapeake Technical Support Laboratory, 1965-1968
U.S.G.S	U.S. Geological Survey Water Quality of the Potomac River and Estuary Hydrologic Data Report, 1978-1981
OEP	Office of Environmental Programs, Maryland Department of Health and Mental Hygiene, 1984-1987; this program was moved to Maryland Department of the Environment 1987-1996 and to the Maryland Department of Natural Resources 1996-present; the current sampling site names were adopted in 2000 to conform to EPA Chesapeake Bay Program station names.

For logistical reasons, Potomac component station LE2.3 is sampled with mainstem stations and mainstem component station CB5.1W is sampled during Patuxent boat cruises.

For analytical purposes, LE2.3 is often considered a tributary station because the water body is “Potomac River”, and station CB5.1W is often considered a mainstem station because the water body is “Chesapeake Bay”. Care should be used when aggregating station water quality data by water body, or

Chesapeake Bay segment. In cases where limits of detection are used in analyses, there may be challenges. (See Appendix XIV for yearly component detection limits).

NOTE: Refer to Appendix I for details on the physical/chemical parameter sampling. Refer to the following work plan/scope of work for details on the plankton monitoring component:

MD Department of Natural Resources. 2017. Quality Assurance Documentation Plan for the Phytoplankton Monitoring Component of the Chesapeake Bay Water Quality Monitoring Program. Annapolis, Maryland, 37 p.

2. MEASURED PARAMETERS

The Chemical and Physical Properties Component of the Chesapeake Bay Water Quality Monitoring Program measures a broad suite of physical and chemical parameters that are indicative of the Bay's eutrophication problem. Several "natural" properties such as salinity and temperature in the water column provide important information for interpretation of water quality indicators.

Some parameters, such as; specific conductance, temperature, dissolved oxygen, and pH, are measured in situ using multiparameter water quality instrumentation manufactured by Hydrolab or Yellow Springs Instruments (YSI). Salinity is calculated from conductivity and temperature. Photosynthetic Active Radiation (PAR) measurements are made in situ using a LI-COR[®] quantum meter and probe. Secchi depth is measured using a weighted 20 cm diameter limnological Secchi disc with alternating white and black quadrants. The disc is attached to a graduated line.

Several Series of Hydrolab multi-parameter instruments have been used by this monitoring program since 1984. Advances in sensor design and measurement technology, and the switch from analog to digital technology have been implemented in the newer Series. Beginning in February 2009, YSI Series 6 instruments were added to the field instrument inventory. Sensor differences on each Series of Hydrolab and YSI instruments are noted in Table 3 and Appendix V, section III B, Routine Sensor Maintenance and Performance Verification.

Hydrolab Series 4041, 2, 3, 4a and 5 instruments had Standard Clark Polarographic Dissolved Oxygen Sensors. Beginning in 2009 all existing Hydrolab Series 5 instruments were converted from Standard Clark Polarographic Dissolved Oxygen Sensors to Optical Dissolved Oxygen Sensors known as Luminescent Dissolved Oxygen (LDO), but temperature, pH, specific conductance and depth sensors were not changed. Since then, Hydrolab Series 4a instruments were systematically replaced with Series 5 instruments equipped with LDO Sensors. In March 2015 all remaining Series 4a instrument equipped with Standard Clark Polarographic Dissolved Oxygen Sensors were replaced with Series 5 instruments equipped with LDO Sensors. Hydrolab Series 4041, 2 and 3 instruments have not been in service for several years. Calibration logs for each instrument will list the date taken out-of-service. Sensor differences for each instrument Series are noted under Routine Sensor Maintenance (see App. V III B).

YSI instruments are equipped with an optical dissolved oxygen sensor (ROX) instead of the Standard Clark Polarographic sensor. YSI temperature, pH, specific conductance and depth sensors are different than their respective Hydrolab sensors, but perform similarly. Both the Hydrolab and YSI optical dissolved oxygen sensors use similar luminescent technology to measure dissolved oxygen.

During 2014 YSI pH sensors in all YSI sondes will be switched from Model 6561 to Model 6589. These sensors are identical and will perform exactly as Model 6561. Model 6561 were only lasting 6 to 9 months of field deployment before replacement was required. Model 6589 is amplified, should respond faster and should last up to two years of field deployment. This trial will determine which model pH sensor is more cost effective to use based on its field deployment longevity and response. Compared to YSI pH sensor Model 6561, YSI pH sensor Model 6589 have greater longevity and reliability. Henceforth, all YSI Series 6 instruments will be equipped with YSI pH sensor Model 6589. These sensors will be replaced once per year.

Since February 2009, Mainstem and Patuxent River cruises have exclusively used YSI Series 6. Prior to February 2009, these cruises exclusively used various Series of Hydrolab instruments. Whether Hydrolab or YSI, field sheets document which instruments were used on each Mainstem and Patuxent River cruises. All other sampling activities use Hydrolab or YSI instruments.

This document may be amended when new Hydrolab and YSI instruments are purchased and instrument protocols changed, and their use and protocols receive approval from the Chesapeake Bay Program Quality Assurance Officer.

The other measured parameters – including nitrogen, phosphorus, carbon and silicon species, total suspended solids, volatile suspended solids and chlorophyll *a* – are determined in the laboratory. Table 3 lists the parameters measured, their detection limits, methods references, and holding times and conditions. Details of sample collection, sample processing and storage, and analytical procedures are described in Appendices I and VII.

The Chesapeake Biological Laboratory Nutrient Analytical Services Laboratory (NASL) has revised all Standard Operating Procedures (SOP) to reflect changes in procedures and instrumentation. These SOPs are reviewed annually and revised when needed. When made, revisions are documented and EPA Chesapeake Bay Program is notified prior to the publication of the affected QAPP.

All laboratory methods used by NASL for DNR analyses have been updated. The updated methods were written to comply with EPA Chesapeake Bay Program Guidelines for Sampling and Analysis (2016) and National Environmental Laboratory Accreditation Conference (NELAC 2003) guidance and recommendations. An organization chart has been created. Documentation of procedures for logging-in and tracking samples, standards and reagents has been developed and is in place.

Appendix VII is an aggregation of NASL methods documents. Table 2 lists the documents in Appendix VII.

Table 2. NASL methods

Water Column Chemistry	Method	Revised
Ammonium Method	<i>Standard Operating Procedure for Determination of Dissolved Inorganic Ammonium (NH₄) in Fresh/Estuarine/Coastal Waters (References Standard Methods 4500-NH₃ G-1997)</i>	26-Apr-2017
Cadmium Nitrate Method	<i>Standard Operating Procedure for Determination of Dissolved Inorganic Nitrate plus Nitrite (NO₃+NO₂) in Fresh/Estuarine/Coastal Waters Using Cadmium Reduction (References EPA 353.2)</i>	26-Apr-2017

Table 2. NASL methods cont.		
Water Column Chemistry	Method	Revised
Enzyme Catalyzed Nitrate Method	<i>Standard Operating Procedure for Determination of Dissolved Inorganic Nitrate plus Nitrite (NO₃+NO₂) in Fresh/Estuarine/Coastal Waters Using Enzyme Catalyzed Reduction (References EPA 353.2, Standard Methods #4500-N C, 4500-NO₃ F)</i>	26-Apr-2017
Inorganic Carbon Method	<i>Standard Operating Procedure for Determination of Aqueous Inorganic Carbon and calculated Carbonate Alkalinity in waters of Fresh/Estuarine/Coastal Waters. (References: ASTM D7573-09)</i>	27-Apr-2017
Nitrite Method	<i>Standard Operating Procedure for Determination of Dissolved Inorganic Nitrite (NO₂) in Fresh/Estuarine/Coastal Waters (References EPA 353.2)</i>	26-Apr-2017
Orthophosphate Method	<i>Standard Operating Procedure for Determination of Dissolved Inorganic Orthophosphate (PO₄) in Fresh/Estuarine/Coastal Waters (References EPA 365.1)</i>	26-Apr-2017
Silicate Method	<i>Determination of Silicate from Fresh, Estuarine, and Coastal Waters Using the Molybdosilicate Method (Reference Method: EPA Method 366.0)</i>	26-Apr-2017
Total Dissolved Nitrogen Enzyme Catalyzed Nitrate Method	<i>Standard Operating Procedure for Determination of Total Dissolved Nitrogen (TDN) and Total Nitrogen (TN) in Fresh/Estuarine/Coastal Waters Using Alkaline Persulfate Digestion of Nitrogen to Nitrate and Measured Using Enzyme Catalyzed Reduction (References EPA 353.2, Standard Methods #4500-N C, 4500-NO₃ F)</i>	26-Apr-2017
Total Dissolved Nitrogen Cadmium Nitrate Method	<i>Standard Operating Procedure for Determination of Total Dissolved Nitrogen (TDN) and Total Nitrogen (TN) in Fresh/Estuarine/Coastal Waters Using Alkaline Persulfate Digestion of Nitrogen to Nitrate and Measured Using Cadmium Reduction (References EPA 353.2, Standard Methods #4500-N C, 4500-NO₃ F)</i>	26-Apr-2017
Total Dissolved Phosphorus Discrete Photometric Analyzer Method	<i>Standard Operating Procedure for Determination of Total Dissolved Phosphorus (TDP) and Total Phosphorus (TP) in Fresh/Estuarine/Coastal Waters Using Alkaline Persulfate Digestion of Phosphorus to Orthophosphate (PO₄) with Colorimetric Analysis by Random Access Discrete Photometric Analyzer (References Standard Methods #4500-P.B.5, #4500 P.E, and EPA Method 365.1)</i>	26-Apr-2017
Total Dissolved Phosphorus Auto Analyzer II System Method	<i>Standard Operating Procedure for Determination of Total Dissolved Phosphorus (TDP) and Total Phosphorus (TP) in Fresh/Estuarine/Coastal Waters Using Alkaline Persulfate Digestion of Phosphorus to Orthophosphate (PO₄) (References Standard Methods #4500-P.B.5, #4500 P.E, and EPA Method 365.1)</i>	26-Apr-2017
Total and Dissolved Organic and Inorganic Carbon Method	<i>Standard Operating Procedure for Determination of Dissolved Organic Carbon/Non-Purgeable Organic Carbon (DOC/NPOC), and Total Organic Carbon (TOC) in Fresh/Estuarine/Coastal Waters using High Temperature Combustion and Infrared Detection. (References: SM5310B, EPA 415.1)</i>	26-Apr-2017
Particulates & Sediments		
Particulate Carbon and Nitrogen Method	<i>Standard Operating Procedure for Determination of Carbon and Nitrogen in Particulates and Sediments of Fresh/Estuarine/Coastal Waters, Plant and Animal Tissue, and Soils Using Elemental Analysis. (Reference Method: EPA 440.0)</i>	26-Apr-2017
Particulate Phosphorus Method	<i>Determination of Total Particulate Phosphorus (TPP) and Particulate Inorganic Phosphorus (PIP) in Fresh/Estuarine/Coastal Waters (Reference Method: EPA 365.1, Rev. 2.0)</i>	26-Apr-2017

Table 2. NASL methods cont.		
Particulates & Sediments	Method	Revised
Total Suspended Solids and Total Volatile Solids Methods	<i>Determination of Total Suspended Solids (TSS) and Total Volatile Solids (TVS) in Waters of Fresh/Estuarine/Coastal Waters. (Reference Method: EPA Method 160.2 and Standard Methods 208 E.)</i>	26-Apr-2017
Chlorophyll Spectrophotometric Method	<i>Standard Operating Procedure for Spectrophotometric Determination of Chlorophyll a in waters and sediments of Fresh/Estuarine/Coastal Areas. (References: SM10200H, EPA 446.0)</i>	27-Apr-2017

The most current versions of NASL methods documents and detection limits are normally maintained on-line by NASL and may be accessed at the following URL: <http://nasl.cbl.umces.edu>.

The Chesapeake Biological Laboratory, Nutrient Analytical Services Laboratory assumed responsibility in January 2009 for analyzing chlorophyll samples. Prior to year 2009, chlorophyll analyses were conducted by the Maryland Department of Health and Mental Hygiene.

Table 3 Water Column Parameters, Detection Limits, Methods References, Holding Times and Conditions.

IN SITU MEASUREMENTS				
Parameter (Units)	Instrument	Detection Limit (or Range)	Method Reference	Holding Time and Condition
Temperature (° C)	Hydrolab Series 4041 and 2	-5 to +45°C	Linear thermistor (HWQIUM-S4041, HWQIUM-S2)	Not applicable <i>in situ</i>
	Hydrolab Series 3, 4a, and 5	-5 to +50°C	Linear thermistor (HWQIUM-S3, HWQIUM-S4a, HWQIUM-S5)	
	YSI Series 6	-5 to +50°C	Thermistor of sintered metallic oxide (YSIUM-S6)	
Depth (m)	Hydrolab Series 2	0-200 m	Strain gauge pressure transducer, non-vented (HWQIUM-S2)	
	Hydrolab Series 3, 4a, and 5	0-100 m	Strain gauge pressure transducer, non-vented, stainless steel (HWQIUM-S3, HWQIUM-S4a, HWQIUM-S5)	
	YSI Series 6	0-61 m	Differential strain gauge transducer, non-vented (YSIUM-S6)	

Table 3 (continued)

IN SITU MEASUREMENTS				
	Instrument	Detection Limit or Range	Method (Reference)	Holding Time and Condition
Dissolved Oxygen (mg/L)	Hydrolab Series 4041, 2, 3, and 4a	0-20 mg/L	Standard Clark Au/Ag Polarographic Cell (HWQIUM-S4041, HWQIUM-S2, HWQIUM-S3, HWQIUM-S4a)	Not applicable <i>in situ</i>
	Hydrolab Series 5	0-50 mg/L	Standard Clark Au/Ag Polarographic Cell (HWQIUM-S5)	
	Hydrolab Series 5	0-20 mg/L	Optical Probe – Luminescent Dissolved Oxygen Probe (LDO) (HWQIUM-S5)	
	YSI Series 6	0-50 mg/L	Optical Sensor – ROX Optical Dissolved Oxygen (YSIUM-S6)	
Specific Conductance	Hydrolab Series 4041	0-200 mS/cm	Four nickel electrode cell with saltwater cell block (HWQIUM-S4041)	
	Hydrolab Series 2	0-150 mS/cm	Six nickel electrode cell with saltwater cell block (HWQIUM-S2)	
	Hydrolab Series 3	0-100 mS/cm	Six nickel electrode cell with saltwater cell block (HWQIUM-S3)	
	Hydrolab Series 4a and 5	0-100 mS/cm	0.25" x 1" oval bore with four graphite electrodes (HWQIUM-S4a, HWQIUM-S5)	
	YSI Series 6	0-100 mS/cm	Four electrode cell (YSIUM-S6)	
pH	Hydrolab Series 4041 and 2	0-14 pH units	Paired bulb type Ag/AgCl glass <i>in situ</i> and rebuildable reference probes – reference probe in sleeve filled with saturated KCl/pH7 buffer and capped with replaceable porous Teflon™ junction (HWQIUM-S4041, HWQIUM-S2)	
	Hydrolab Series 3, 4a, and 5	0-14 pH units	Paired bulb type Ag/AgCl glass <i>in situ</i> probe and Silver pellet reference probe – reference probe in sleeve filled with 4M KCl saturated with AgCl and capped with replaceable porous Teflon™ junction (HWQIUM-S3, HWQIUM-S4a, HWQIUM-S5)	
	YSI Series 6	0-14 pH units	Combined glass bulb type electrode with Ag/AgCl reference electrode (YSIUM-S6)	

Table 3 (continued)				
IN SITU MEASUREMENTS				
	Instrument	Detection Limit or Range	Method (Reference)	Holding Time and Condition
Secchi Depth (m)		0.1 - 7.0 m	20 cm diameter disk with alternating black and white quadrants (Welch, 1948)	Not applicable <i>in situ</i>
Light Attenuation* (Photosynthetic Active Radiation) (two measurements - one from boat and one taken at depth with an up sensor)	LI-COR Model LI1400	400–700 nm	Parsons (1977); Smith (1969), CBP F01	
* Light Attenuation is not measured by MD DNR on Tributary cruises except the Patuxent River. Light attenuation is measured on Mainstem cruises.				
GRAB SAMPLES				
Parameter (Units)	NASL Detection Limit	Method (Reference)		Holding Time and Condition
Ammonium (mg/L as N)	0.001 mg N/L	EPA method 350.1 (EPA 1993) and SM 4500-NH ₃ G (1997) Aquakem 250		Freezing-28 d
Chlorophyll <i>a</i> (µg/L)	0.62 µg/L	Standard Methods 10200H, 21st Ed, EPA 446.0		Freezing-28 d
Dissolved Organic Carbon (mg/L as C)	0.24 mg/L	Sugimura and Suzuki (1988), EPA 415.1		Freezing-28 d
Dissolved Silicate (mg/L as Si)	0.0536 mg/L	EPA method 366.6 (EPA 1997) Aquakem 250, EPA 366.0.		4°C - 28 d
Nitrite (mg/L as N)	0.0007 mg/L	EPA method 353.2 (EPA 1993) Aquakem 250		Freezing-28 d
Nitrite + Nitrate (mg/L as N)	0.0007 mg/L	EPA method 353.2 (EPA 1993) and enzymatic nitrate method. Instrumentation used: Aquakem 250 (enzyme reduction) and AutoAnalyzer II (cadmium reduction), ASTM D7781		Freezing-28 d

Table 3 (continued)			
GRAB SAMPLES			
Parameter (Units)	NASL Detection Limit	Method (Reference)	Holding Time and Condition
Orthophosphate (mg/L as P)	0.0006 mg/L	EPA method 365.1 (EPA 1993) Aquakem 250	Freezing-28 d
Particulate Carbon (mg/L as C)	0.0633 mg/L	EPA method 440.0 (EPA 1997)	Freezing-28 d
Particulate Nitrogen (mg/L as N)	0.0105 mg/L	EPA method 440.0 (EPA 1997)	Freezing-28 d
Particulate Phosphorus (mg/L as P)	0.0035 mg/L	Aspila et al. 1976 Aquakem 250, EPA 365.1.	Freezing-28 d
Pheophytin a (µg/L)	0.74 µg/L	Standard Methods 10200H, 21st Ed, EPA 446.0	Freezing-28 d
Total Dissolved Nitrogen (mg/L as N)	0.05 mg/L	Aquakem 250 and AutoAnalyzer II D'Elia et al. 1977; Valderrama 1981, Alkaline persulfate digestion. (Analysis by both by cadmium reduction and enzyme reduction post Alkaline persulfate digestion), EPA 353.2	Freezing-28 d
Total Diss. Phosphorus (mg/L as P)	0.0015 mg/L	Aquakem 250 and AutoAnalyzer II Valderrama 1981, Alkaline persulfate digestion, EPA 365.1	Freezing-28 d
Total Suspended Solids (mg/L)	2.4 mg/L	Standard Method (APHA 19th or 20th edition) Method 2540 D	Freezing-28 d
Volatile Suspended Solids (mg/L)	0.9 mg/L	Standard Method (APHA 19th or 20th edition), Method 2540 E	Freezing-28 d

REFERENCES for Table 3:

American Public Health Association (APHA), *Standard Methods for the Examination of Water and Wastewater, Method Number 10200H*, 21st Edition, 2005.

American Public Health Association (APHA), *Standard Methods for the Examination of Water and Wastewater, Method Number 2540 D*, 20th Edition, 1998.

American Public Health Association (APHA). 1975. Method 208D, total non-filterable residue dried at 103-105°C (total suspended matter), in *Standard Methods for the Examination of Water and Wastewater*, 14th Edition. APHA: Washington, D.C. 1193 p.

Aspila, I., H. Agemian and A. S. Y. Chau. 1976. A semi-automated method for the determination of inorganic, organic and total phosphate in sediments. *Analyst* 101:187-197.

D'Elia, C. F., P. A. Steudler and N. Corwin. 1977. [Determination of total nitrogen in aqueous samples using persulfate digestion](#). *Limnol. Oceanogr.* 22:760-764.

Hydrolab Corporation. June 1981. *Hydrolab Digital 4041 Operation and Maintenance Instructions*. Austin, TX. (HWQIUM-S4041)

Hydrolab Corporation. Revision A, February 1985. *Hydrolab Surveyor II Operating Manual*. Austin, TX. (HWQIUM-S2)

Hydrolab Corporation. Revision B, April 1995. *H2O Water Quality Multiprobe – Operating Manual*. Austin, TX. (HWQIUM-S3)

Hydrolab Corporation. Revision G, April 1999. *DataSonde 4 and Minisonde Water Quality Probes – User's Manual*. Austin, TX. (HWQIUM-S4a)

Hydrolab Corporation. Edition 3, February 2006. *Hydrolab DS5X, DS5, and MS5 Water Quality Probes – User Manual*. Loveland, CO. (HWQIUM-S5)

Parsons, T. R., Takahashi, M. and B. Hargrave. 1977. *Biological Oceanographic Processes*. Pergammon Press. Oxford. 332 p. (Pages 71-85).

Patton, C. J., A.E. Fischer, W.H. Campbell and E.R. Campbell. 2002. [Corn leaf nitrate reductase- A nontoxic alternative to cadmium for photometric nitrate determinations in water samples by air-segmented continuous-flow analysis](#). *Env Sci. and Technology* 36(4):729-735

Smith, R. C. 1969. An underwater spectral irradiance collector. *J. Mar. Res.* Vol. 27: 341-351.

Sugimura, Y. and Y. Suzuki. 1988. [A high temperature catalytic oxidation method for the determination of non-volatile dissolved organic carbon in seawater by direct injection of a liquid sample](#). *Mar. Chem.* 24:105 - 131.

US Environmental Protection Agency (EPA). 1997. US EPA Method 440.0. [Determination of Carbon and Nitrogen in Sediments and Particulates of Estuarine/Coastal Waters Using Elemental Analysis. Revision 1.4](#). National Exposure Research Laboratory, Office of Research and Development, US Environmental Protection Agency: Cincinnati, OH.

US Environmental Protection Agency (EPA). 1993. [Methods for the Determination of Inorganic Substances in Environmental Samples](#) EPA-600/R-93/100.

US Environmental Protection Agency (EPA). 1979. [Methods for Chemical Analysis of Water and Wastes](#). EPA-600/4-79-020. 460 p.

Valderrama, J. C. 1981. [The Simultaneous Analysis of Total Nitrogen and Total Phosphorus in Natural Waters](#). *Mar. Chem.* 10:109-122.

Welch, P.S. 1948. Chapter 11 in *Limnological Methods*. Blakiston: Philadelphia, PA. pp. 159-167.

3. FIELD MEASUREMENTS AND SAMPLING

Sampling procedures have been formulated for each part of Maryland's Chemical and Physical Properties Component of the Chesapeake Bay Water Quality Monitoring Program to take measurements that meet the program objectives in an efficient, cost-effective, and logistically practical manner.

As defined in the Scope of Work, a total of 22 mainstem stations and 60 tributary stations are included in the Chemical and Physical Properties Component of the monitoring program (see Figure 1 and Table 1 above in Section 1). Water column samples are collected at least once a month at most stations, for a minimum of twelve samplings per year. In the Chesapeake mainstem, sampling will be conducted twice monthly in July and August of 2017 and June 2018, and once monthly during the remaining months, for a total of fifteen samplings in the period of July 1, 2017 - June 30, 2018. However, at eastern and western transect mainstem stations, samples will not be collected from November through February, resulting in only eleven samplings a year. Nutrient samples will not be collected during the second July 2017 survey. On the Potomac and Patuxent and smaller tributaries, twelve samplings will be conducted per year. The current frequency of sampling for each station is shown in Table 1 (provided above in Section 1).

The water column will be profiled for temperature, conductivity, dissolved oxygen, and pH using an *in situ* probe that transmits data to a shipboard readout via cable. Profiling will be conducted at a minimum resolution of 2 m sampling intervals. In strata where there is appreciable change in conductivity or dissolved oxygen (i.e., at the pycnocline), 1 m intervals will be sampled. The protocols for determining profiling depths are detailed in Appendix I.

Water column grab samples collected for subsequent analysis in the laboratory will be taken by submersible pump or water bottle. The number of depths sampled per station is listed in the last column of Table 1.

One or two depths will be sampled at stations that do not normally exhibit vertical density stratification. For stations where samples are collected at a single depth, the grab will be collected from depth of either 0.0 m or 0.5 m depending on the site. The depths of 0.5 m and 1 m above bottom will be sampled at sites where grabs are made at two depths.

Four depths will be sampled at stations that are normally density stratified: 0.5 m below the surface, 1.5 m above the upper limit of the pycnocline, 1.5 m below the lower limit of the pycnocline, and 1 m above the bottom. Grab sampling depths relative to the pycnocline will be determined according to the protocols described in Appendix I.

Above pycnocline depth and below pycnocline depth grab samples are collected at the following stations: CB2.2, CB3.1, CB3.2, CB3.3C, CB4.1C, CB4.1E, CB4.2C, CB4.3C, CB4.3E, CB4.4, CB5.1, CB5.1W, CB5.2, CB5.3, EE1.1, EE2.1, EE3.1, EE3.2, ET4.2, ET5.2, LE2.2, LE2.3, RET2.4 and WT5.1.

Four depth grab samples are also collected at six other sites where mid-water sampling is conducted at fixed depths to maintain consistency with historical-station sampling depths. In addition to surface and bottom water samples at the six Patuxent boat survey stations, upper mid-water samples are collected at 3 meters

depth. At stations RET1.1 and TF1.5, lower mid-water samples are collected at 6 meters. Lower mid-water samples are collected at 9 meters at stations LE1.1 and LE1.4. At stations LE1.2 and LE1.3 lower mid-water samples are collected at the depth of 12 meters.

Grab samples on the Potomac boat survey are collected at three depths at five stations. In addition to surface and bottom water samples, to maintain consistency with historical-station sampling depths, mid-depth samples (M) are collected at 4.6 meters at stations RET 2.2, TF2.4, TF 2.3 and TF 2.2. The station TF 2.1 mid-depth sample is collected at 9.1 meters.

Details on filtration, containers, and storage techniques can also be found in Appendix I. This sampling protocol provides one or two measurements of the water column in well-mixed non-stratified regions and two additional measurements - one in the surface mixed layer, and one in the bottom mixed layer - where the estuary is stratified into the typical two-layered flow pattern.

For the mainstem stations only, when there is an odor of hydrogen sulfide present in the bottom sample or the below pycnocline sample, a Hach Kit test for hydrogen sulfide presence on the bottom and/or below pycnocline sample(s) will be performed.

Water transparency will be measured by Secchi depth, determined in meters using a 20 cm standard Secchi disc lowered into the water column with a calibrated rope. Observations will be made on the shady side of the boat.

4. LABORATORY ANALYSIS

All laboratory-measured parameters will be analyzed at the University of Maryland Center for Environmental Science (UMCES), Chesapeake Biological Laboratory (CBL), Nutrient Analytical Services Laboratory (NASL). See Appendix VII for the NASL Standard Operating Procedures and analytical methods.

The NASL assumed responsibility for analyzing active chlorophyll *a* and pheophytin *a* in January 2009. See Appendix VII for NASL chlorophyll analysis methods. Maryland Department of Health and Mental Hygiene's (DHMH) Environmental Chemistry Division analyzed chlorophyll and pheophytin samples prior to January 2009.

5. DATA MANAGEMENT, VERIFICATION AND DOCUMENTATION

Data collection for the Chemical and Physical Properties Component of the Chesapeake Bay Water Quality Monitoring Program will begin when measurements from field recording instruments are entered onto field data sheets. A field log book will be used to document any problems encountered in the field that might affect the field parameters or samples brought back to the laboratory. The senior scientist, on board each cruise, will ensure that all measurements are taken properly. All data acquisition processes in the field and laboratory measurements will be recorded in the Cruise Report to ensure data quality. After field personnel complete data sheets for a given calendar month, they will make photocopies of the sheets to keep in the Field Office, and send the original field sheets to data management staff at the DNR Tawes Building. The Field Office will also generate a Cross Reference Sheet for each set of field sheets, which is sent to the

DNR data management personnel along with the field data sheets. The Cross Reference Sheet allows data management personnel to know what field, nutrient, lab, and chlorophyll lab sheets to expect. See Appendix II for field sheets and associated documentation, Appendix III for a Cross Reference Sheet and documentation, and Appendix IV for Cruise Report Documentation and Procedures.

Nutrient laboratory data sheets (nutrient volume sheets) will be initiated in the field. The nutrient lab sheets will be used to record basic information about samples, such as station, date, depth, and volume filtered. The sheets will serve as sample transfer sheets, traveling with the samples to CBL's Nutrient Analytical Services Lab for nutrient or chlorophyll analysis. Both the sheets and the samples will be logged in at the NASL.

At CBL, data generated from nutrient analyses will be recorded directly to an electronic file. CBL keeps active control charts. Each instrument has an operator dedicated to that instrument. The dedicated operator is responsible for keeping track of the slopes of the regression analysis for that instrument to determine if the analyses are "in control." The analyst will review the data and, if the data exceed their control limits, the entire run will be re-analyzed. Re-analysis can occur for any number of reasons, such as; a poor r-squared (R^2) on the standard curve, the wrong set of pump tubes (which would provide abnormally low peaks), or high blank values (in the case of DOC). See Appendix VII for CBL's procedures and methods.

When laboratory staff members complete the nutrient lab sheets and chlorophyll lab sheets, the sheets will be sent to the DNR Tawes Building along with any electronic files that have been generated. See Appendix II for nutrient/chlorophyll lab sheets, and associated documentation. See Appendix X for a list of codes used on the sheets and to qualify analytical results when necessary.

Data review and verification will be conducted at four levels by DNR data management personnel.

At the first level, DNR data management personnel will review cross reference sheets and field data sheets: (1) comparing field sheets to cross reference sheets to ensure that all field sheets have been received; (2) reviewing all field sheets to check that they are filled out completely and legibly, and; (3) sending the sheets to a data entry service for keypunch (see Appendix XI for procedures). At the data entry service, the field sheet data values will be double-entered to minimize errors at the keypunch stage. The entered field data will be sent back to DNR as electronic files for further processing.

At the second level, a Data Processing Programmer will generate reports and plots for data verification using the Water Quality Import v3 software. The WQ Import v3 software was designed in late 1998 and completely developed in 2000 in Microsoft Access. The WQ Import v3 software will be used to import data and cross reference files and to conduct data management activities, such as performing initial data checks, conducting major key field checks, performing parameter range checks (including measured and calculated parameters), conducting combination checks for specific parameters, generating error reports

and verification plots, generating a "data verified list," reformatting data, creating a database, and submitting data. Data checks are listed in Exhibit 1.

Third, system printouts or PDF files of each data set will be sent to a biologist and the Quality Assurance Officer for verification and editing. The Quality Assurance Officer and DNR biologists will ensure that measured or calculated information for all types of data are correct and that the codes associated with parameters are properly established. In addition, the Quality Assurance Officer will identify data problems, provide data correction instructions, and coordinate data correction activities. Possible errors will be identified, and sent to the laboratory or field office for verification or verified over the phone. Any necessary corrections will be written on an edit form, which will be given to a programmer. The programmer will make changes to correct the electronic data set, re-run the verification programs, and update the verification reports and plots. This procedure will be repeated until a clean data set is produced. Sample verification reports and plots and an example of an edit request are provided in Appendix XII.

The fourth step will be for data management staff to ensure that the overall data verification processes are completed, all data errors are corrected, and that the finalized data sets are created and formatted to be consistent with historical data sets. The final data set combining the field, lab, and chlorophyll data is created as an "MDB file" after the completion of data verification processes. This final data set will be stored in the designated DNR data library subdirectory on Local Area Network server for data user access. A formatted submission data set and associated data documentation will also be transferred to the Chesapeake Bay Program Data Center on a monthly basis.

The data management process is diagrammed in Figure 2.

Exhibit 1. Data Verification Conducted on Water Quality Data

- (1) Individual Data Parameter Checks:
 - (a) Range check for numeric data parameters (reports error if data are outside the normal range for that parameter).
 - (b) Character validation check for character data parameters (reports error if the character data are not appropriate for that parameter).
- (2) Parameter Combination Checks:
 - (a) Field Data:
 - Sample layer depth check (checks to make sure layer depths are appropriate, e.g., reports error if surface layer depth is greater than 1.0 m, surface depth is greater than bottom depth, etc.).
 - Upper and lower pycnocline check (reports error if pycnocline depths are outside expected range).
 - Maximum and minimum wind parameter check (reports error if minimum wind exceeds maximum wind).
 - (b) Laboratory Data:
 - APC code check for all laboratory related parameters (reports if APC code has been reported).
 - G code (greater than or less than detection limit flag) check for all laboratory related parameters (reports if lab has flagged values as greater or less than the detection limit).
 - Parameter combination check for the following parameters:
 - Parameters PO4 and TDP (reports error if $PO4 > TDP$).
 - Parameters NO23, NH4, and TDN (reports error if $NO23 + NH4 > TDN$).
 - Parameters NO2 and NO23 (reports error if $NO2 > NO23$).
 - (c) Chlorophyll Data: APC code checks with light path, extraction volume, and/or optical density parameters (reports error if values are outside expected range).
- (3) Verification Plots for Review: Sampling dates and times and values for all chemical and physical parameters are plotted by station for review by biologists and the Quality Assurance Officer (QAO). Biologists and the QAO look at patterns and identify any outliers or unusual values to be checked for errors.

Data management flow chart
Data Entry through production of Final Master Data Set

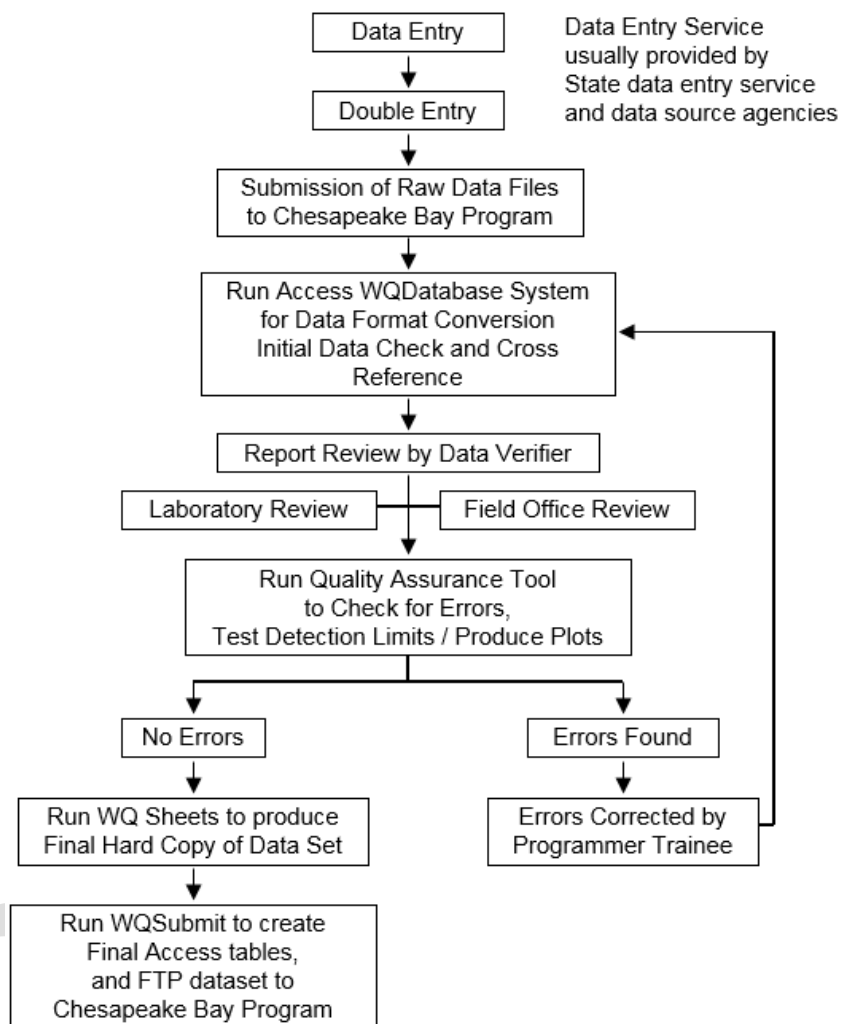

Figure 2. Data Management Flow Chart

A data tracking system has been designed and implemented to track the progress of data through the data management system. Data Status Forms will be assigned to all data files received (see Appendix IX for example sheet and documentation). Data sheets and tracking sheets used in data management will be stored at the DNR Tawes Building for seven years. The data tracking system is diagrammed in Figure 3.

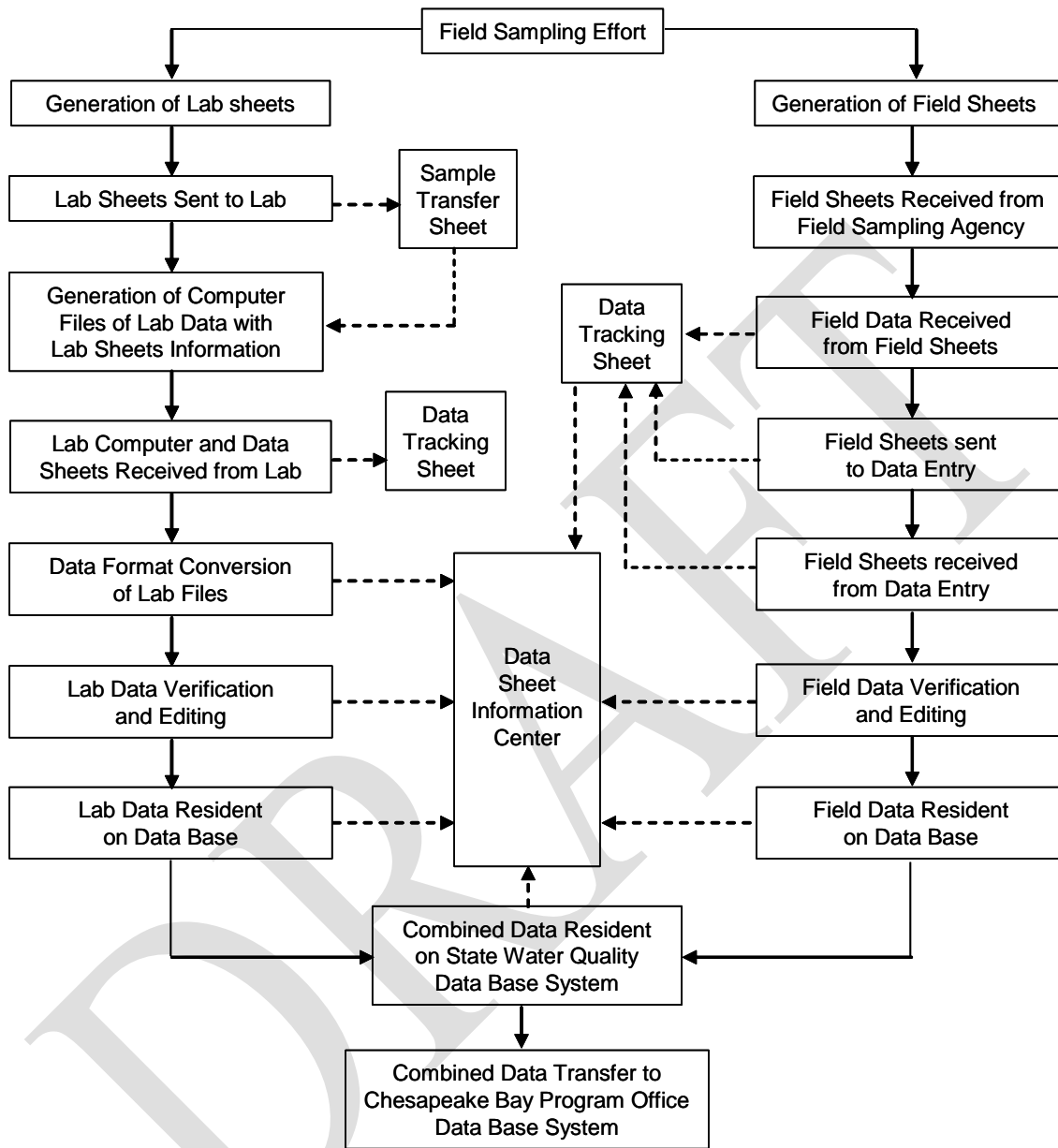

Figure 3. Data Tracking Flow Chart

Additionally, data from duplicate field samples will be reviewed by a data analyst.

6. PROJECT QUALITY ASSURANCE/QUALITY CONTROL

The data collected as part of the Chemical and Physical Properties Component of the Chesapeake Bay Water Quality Monitoring Program are used in making management decisions regarding Chesapeake Bay water quality as described in the Introduction. DNR will follow specific procedures to ensure that the design is properly implemented and that monitoring measurements are made and managed with sufficient accuracy, precision, and detection limits. General discussions of quality assurance and quality control aspects associated with accuracy, precision, data management, reporting, and audits are provided in the subsections below. For detailed descriptions of quality assurance and control procedures used in the field, the laboratories, and data management, see the attached appendices.

6.1 Accuracy

The accuracy (closeness to the true value) of the collected data will be controlled and assured by the proper use, calibration, and maintenance of both field and laboratory equipment for the measurement of physical and chemical parameters. All instruments are identified by a unique number, used as an index for documentation of calibration, repair, and preventive maintenance. Where possible, standards used for calibration purposes will be validated against a primary standard such as those available from the National Institute of Standards and Technology (NIST).

Daily quality control checks (including the running of blanks and standards) will be used to control and assure laboratory accuracy. See Appendix VII for details on the frequency of running blanks and standards and for additional procedures for laboratory quality assurance and control.

Accuracy of laboratory results will also be assessed through DNR's participation in the Chesapeake Bay Coordinated Split Sample Program ([CSSP](#)), a split sampling program in which the coordinated split samples are analyzed by five laboratories involved in Chesapeake Bay monitoring. CSSP was established in June 1989 to establish a measure of comparability between sampling and analytical operations for water quality monitoring throughout the Chesapeake Bay and its tributaries. DNR follows the protocols in the [Chesapeake Bay Coordinated Split Sample Program Implementation Guidelines Rev. 4](#) (EPA 2010) and its revisions. Split samples are collected quarterly. Results are analyzed by appropriate statistical methods to determine if results differ significantly among labs. When a difference occurs, discussion begins regarding techniques and potential methods changes to resolve discrepancies. A summary of the coordinated split sample program and a copy of the split sample custody log are provided in Appendix VIII.

Additionally, CBL's Nutrient Analytical Services Laboratory will participate two times per year in the United States Geologic Survey (USGS) reference sample program and will permit USGS to release the results to the Chesapeake Bay Program Quality Assurance Officer.

Procedures to control and assure the accuracy of field measurements involve the calibration of field instruments, the verification of these calibrations, equipment maintenance, and collection of filter blanks. These procedures are detailed in Appendices V and VI.

When field replicate control limits are exceeded, or when field blank values exceed lowest calibration standards, information about the issue is presented to the Data Integrity Work Group (DIWG). DIWG may suggest corrective actions to field and laboratory procedures.

6.2 Precision

Precision (repeatability) of the chemical analytical methods will be determined and documented from duplicate analyses. Precision of the entire measurement system for laboratory-analyzed parameters, including field processing, storage, and chemical analysis, can be assessed from duplicate field samples. Duplicate field samples will be routinely collected approximately every 20 samples, as described in Appendix I. Differences between the laboratory results for duplicate field samples will be examined using control charts. Comparisons of field replicates that result in a relative percent difference exceeding the upper control limit will be documented in quarterly reports to the EPA Chesapeake Bay Program. The protocols for duplicate analyses in the laboratory are described in the Standard Operating Procedures for the Nutrient Analytical Services Laboratory in Appendix VII.

6.3 Data Review and Data Verification

Data review and data verification ensure the quality assurance and quality control of data. Corrective actions routinely taken when data checks fail are detailed above in Section V, DATA MANAGEMENT, VERIFICATION AND DOCUMENTATION.

6.4 Audits

Performance audits for chemical analyses conducted at the University of Maryland Center for Environmental Science, Chesapeake Biological Laboratory, Nutrient Analytical Services Laboratory (NASL) are based on the results of samples distributed by the EPA Chesapeake Bay Program Blind Audit Program. These samples must fall within the 95% confidence interval for acceptance. If results fall outside this range, corrective actions for each parameter and measurement are taken. NASL prepares the blind audit samples for all participating laboratories and also analyzes some of those samples. For dissolved nitrogen and dissolved phosphorus, a laboratory quality assurance officer determines the concentrations in the ampules, prepares the concentrates, and seals the ampules. A different person then analyzes the sample blindly. For the particulate fractions (particulate carbon/particulate nitrogen and particulate phosphorus), samples are filtered and then placed in pouches in the freezer until they are ready to be sent to the other CBP participating laboratories. As of 26-April-2017 the following labs were participating in the Blind Audit program: [College of William and Mary - Virginia Institute of Marine Science, Analytical Services Lab](#); [Delaware DNREC-DWR](#); [Hampton Roads Sanitation District - CEL](#); [Maryland Dept. of Health and Mental Hygiene](#); Klamath Tribe Research Station; [Massachusetts Water Resource Authority](#); [New Jersey Public Health, E&A Lab, New Jersey State Police HQ Campus](#); [Old Dominion University, Water Quality Laboratory](#); [Patrick Center for Environmental Research - Academy of Natural Sciences of Philadelphia](#); [Pennsylvania Department of Environmental Protection - Bureau of Laboratories](#); [University of Connecticut Center for Environmental Science and Engineering](#); [University of Maryland, CES, Chesapeake Biological Laboratory](#); [University of Maryland, CES, Horn Point Laboratory](#); [USGS - Indiana Water Science Center](#); [Virginia Division of Consolidated Laboratory Services](#) and [Virginia Polytechnic Institute - Occoquan Laboratory](#).

Once annually, the EPA Chesapeake Bay Program quality assurance officer will conduct an on-site audit of the mainstem laboratory and field programs. The DNR Quality Assurance Officer will communicate on a weekly basis with the field program staff and confers with the laboratory quality assurance officers to ensure that all aspects of the program are being conducted properly.

Internal audits of field sampling will be regularly conducted annually by the Field Quality Assurance Officer. Field sampling audit results will be communicated to the Quality Assurance Officer.

6.5 Reporting

Quality assurance information for field duplicate samples in the mainstem and tributaries will be stored within the routine computerized water quality data sets as replicate observations that can be used to assess precision. For both the tributary and mainstem chemistry, laboratory quality assurance/control information on duplicates and spikes will be stored in a computerized data set as a companion to the regular data sets and submitted to the Chesapeake Bay Program Office (CBPO) quarterly. The DNR Quality Assurance Officer will provide a summary of any relevant quality assurance/control information in quarterly progress reports for the mainstem program. The EPA Chesapeake Bay Program quality assurance officer will report on results of field and laboratory audits for the mainstem program.

6.6 Data Quality Indicators

To ensure that data are of the quality required to support Chesapeake Bay Program management decisions, Maryland's Chesapeake Bay Water Quality Monitoring Program will strive to provide monitoring data of known and consistent quality to the CBPO by generally following the guidelines outlined in Chapter II, Section E of the *Recommended Guidelines for Sampling and Analysis in the Chesapeake Bay Monitoring Program, August 1996* (EPA 1996). These guidelines recommend precision goals of field and lab measurements of <20 percent of the coefficient of variation; accuracy goals within 80 to 120 percent, and the completeness goals of 100 percent. Detection limit ranges are provided in Table 3 above. Field measurement minimum detection limits are listed in Table 4.

Table 4. Minimum Detection Limits for Field Measurements

PARAMETER	MINIMUM DETECTION LIMIT
Water Temperature	0.1 °C
Depth	0.5 m
Dissolved Oxygen	0.0 mg/L
Conductance, Specific	Down to 1 micromhos/cm at low levels (accurate to 3 significant digits)
pH	0.1 pH units
Secchi Depth	0.1 m
Salinity	0.1 ppt
Light Attenuation (PAR)	0.05% at 100% light

7. DATA ANALYSIS AND REPORTING

The key objectives of the Chesapeake Bay water quality monitoring program are to accurately describe the current state of the Bay mainstem and tidal tributaries and to detect long-term trends. Trends are analyzed using techniques recommended by the Chesapeake Bay Program's Tidal Monitoring and Analysis Work Group (TMAW, formerly the Data Analysis Work Group—DAWG), including the *Guidance for the Analysis of Water Quality Trends in the Chesapeake Bay* (Eskin et al. 1993) developed by DAWG in 1993. This published guidance provides general discussion on developing analytical objectives, reviewing and assembling data, and interpreting results. Data analysis topics covered in the document include:

- Selecting appropriate spatial and temporal scales;

- Exploring data characteristics such as distribution, censoring, trend characteristics (step versus monotonic), variances, seasonality, persistence, and missing data;
- Adjusting for flow variability; and,
- Considering the power and robustness of the tests.

The document also briefly discusses specific statistical tests, such as the seasonal Kendall test, Van Belle and Hughes intrablock tests, and Mann-Kendall tests, and corrections for serial dependence. TMAW made recommendations and had a goal of updating the *Guidance for the Analysis of Water Quality Trends in Chesapeake Bay* to help analysts reach technically sound conclusions and interpretations and to foster a consistent approach to trend analysis among the various investigators and multiple jurisdictions involved in the monitoring and analysis of Chesapeake Bay water and habitat quality.

In 2014, the Scientific, Technical Assessment & Reporting ([STAR](#)) team formed the Integrated Trends Analysis Team (ITAT). Many TMAW goals have been subsumed by similar ITAT goals. ITAT goals are listed below.

- Gather researchers and analysts from various governmental, academic, non-profit, and private organizations for biannual meetings to identify the broad scope of on-going work related to trends and patterns of water quality in the Chesapeake watershed and estuary.
- Discover previously un-identified linkages among the ongoing research activities of participating individuals and organizations.
- Develop a standard set of analysis tools that can be applied in any relevant ecosystem within the Chesapeake watershed and estuary.
- Foster increased collaboration and awareness of ongoing research.
- Provide a forum for bringing findings to the broader Chesapeake Bay management community

Beyond analysis of the Maryland monitoring data, DNR staff members participate in Chesapeake Bay Program monitoring activities to produce Bay-wide analyses and reports with cooperating state, federal and local agencies. This activity leads to a better Bay-wide understanding of water and habitat quality and addresses the linkage between water quality and living resources. The Bay Agreement of 1987 also called for a re-evaluation of the nutrient strategies in 1991 and in 1997. Annual updates of water and habitat quality status and trends also were analyzed and summarized in *The State of the Chesapeake Bay and the Watershed: A Progress Report January 3, 2008*, the *Chesapeake Bay Nutrient Reduction Progress & Future Directions Nutrient Reduction Reevaluation Summary Report* (CBP 1997), *Bay Barometer: Health and Restoration in the Chesapeake Bay Watershed* (2015-2016), and Basin Summary Reports.

Beginning in 2011, [water quality status and trends analytical results](#) became available via an internet mapping application, rendered on MD DNR's Eyes on the Bay web site that allows users to select parameters and metrics. [Detailed methods for Status and Trend calculations](#) are available via the application. Status and Trend information including 2013 data were made available in 2014.

The monitoring data also are used extensively in mathematical modeling efforts to project the water quality response of Chesapeake Bay to various management alternatives. Bay models are regularly updated and refined. *The 2010 Chesapeake Bay Eutrophication Model* combines interactive models. Additional related information may be accessed by downloading the *Chesapeake Bay Program Environmental Modeling – Backgrounder*. Results for earlier versions of the model have already been used to set nutrient reduction goals agreed to in the 1987 Bay Agreement and affirmed by the 1991 and 1997 Re-evaluations.

Other components of the DNR Chesapeake Bay Water Quality Monitoring Program are required to produce cumulative "Level I" data reports annually that describe the results of that component from the inception of the programs. These components include the Benthic, Ecosystem Processes, and River Input Programs. In addition to documenting the results of the individual monitoring components, these cumulative reports are intended to serve as "building blocks" for more integrated levels of analysis among the coordinated components.

8. PROJECT ORGANIZATION AND RESPONSIBILITY

This section lists the individuals responsible for the major aspects of the Chemical and Physical Properties Component of Maryland's Chesapeake Bay Water Quality Monitoring Program.

Director and Principal Investigator: Thomas Parham, Tidewater Ecosystem Assessment, DNR.

RESPONSIBILITIES: The director and principal investigator is responsible for overseeing the administrative aspects of the program including fiscal management, coordination among other DNR managers and coordination with cooperating agencies and institutions. This individual is also responsible for the technical design, conduct and data analysis of the program.

Quality Assurance Officer: Christine Conn, Chesapeake and Coastal Watershed Services, DNR.

RESPONSIBILITIES: The quality assurance officer is responsible for documenting and assuring the conduct of field, laboratory, and data management procedures that comprise this study.

Field Sampling Operations: Kristen Heyer, Monitoring Field Office, DNR.

RESPONSIBILITIES: This individual is responsible for administration of the field sampling activities including sample collection, sample storage and sample delivery to laboratories.

Field Sampling Quality Assurance Officer: Greg Gruber, Monitoring Field Office, DNR.

RESPONSIBILITIES: This individual is responsible for assuring the quality of field procedures and equipment used in this study.

Laboratory Analyses/Water Column Chemistry: Jerry Frank, University of Maryland, Chesapeake Biological Lab, Nutrient Analytical Services Laboratory.

RESPONSIBILITIES: This individual is responsible for analysis of water samples collected in the mainstem and tidal tributaries.

Communications - Field: Thomas Parham, Tidewater Ecosystem Assessment, DNR.

RESPONSIBILITIES: This individual is responsible for communications with Field Supervisors.

Communications - Laboratory: Renee Karrh, Thomas Parham, Tidewater Ecosystem Assessment, DNR

RESPONSIBILITIES: These individuals are responsible for communications with Laboratory Supervisors.

Data Management: Mark Trice, Tidewater Ecosystem Assessment, DNR

RESPONSIBILITIES: This individual is responsible for overseeing the management of field and laboratory data collected under this program; managing historical field and laboratory data collected under this program; and maintaining existing data management software.

9. PROCEDURAL CHANGE PROTOCOL

Any permanent changes to field, laboratory or data management procedures must be approved by the Chesapeake Bay Program Office Quality Assurance Officer. Proposed changes are to be documented and submitted within 30 days using the Chesapeake Bay Program Procedure Modification Tracking Form (PMTF). (See Appendix XIII for example Chesapeake Bay Program Procedure Modification Tracking Form).

The CBP Quality Assurance Coordinator must be notified of the intent to make any substantial or long-term change to a procedure or method, either in the field or laboratory. These changes include items such as instrument type and sampling stations.

The effects of any change in analytical instruments, reagents, calibration, digestion procedure, etc., should be quantified, documented and submitted to the CBP QA Coordinator prior to implementing.

All modifications should be documented using the Chesapeake Bay Monitoring Program Procedure Modification Tracking Form (PMTF). The completed PMTF should be submitted to the State agency Monitoring Coordinator, CBP Quality Assurance Coordinator and CBP Water Quality Database Manager.

Minor changes in field or laboratory procedures, including detection limit changes, should be documented in the CIMS metadata and data submission tables.

Minor events and problems encountered during Chesapeake Bay mainstem cruises may be reported in the CBP Monitoring Cruise Report and submitted to the State agency, who will then forward the information to the Chesapeake Bay Program Office. For smaller sampling events, all remarks relating to field work may be reported in the CIMS WQ_Cruise and WQ_Event tables.

Modifications due to emergencies during a sampling cruise are authorized by the Chief Scientist with priorities for safety and completion of the cruise. The change should be documented within 30 days after the cruise, in either the PMTF or the Monitoring Cruise Report, depending on size or potential impact of the deviation on the data.

10. LOG OF SIGNIFICANT CHANGES

Procedural changes have been made over the years to address evolving water quality sampling program requirements, goals, budgetary changes, recommendations of the Analytical Methods and Quality

Assurance Work Group and other issues. (See Appendix XIV, LOG OF SIGNIFICANT CHANGES).

The Change Log is a chronological list of changes to the monitoring program. The Log will be updated annually. The list is comprised of change implementation-dates and brief descriptive summaries of modified procedures. Additionally, changes in measured parameter analytical detection limits are summarized in tabular form.

11. REFERENCES

Alden, R.W., M.F. Lane, H. Lakkis, and J.C. Seibel. 1994. *An Assessment of the Power and Robustness of the Chesapeake Bay Program Water Quality Monitoring Program: Phase II - Refinement Evaluations*. Prepared for Virginia Department of Environmental Quality by Old Dominion University, Applied Marine Research Laboratory. AMRL Technical Report No. 965.

<http://archive.chesapeakebay.net/pubs/calendar/MONSC_06-05-09_Handout_4_10309.pdf>.

BAY BAROMETER 2015 – 2016, Health and Restoration in the Chesapeake Watershed

< http://www.chesapeakebay.net/documents/2015-2016_Bay_Barometer.pdf >.

Cerco, C., S. Kim, M. Noel. 2010. *The 2010 Chesapeake Bay Eutrophication Model*.

<http://www.chesapeakebay.net/content/publications/cbp_55318.pdf>.

Chesapeake Bay Program, Analytical Segmentation Scheme, Revisions, Decisions and Rationales, 1983-2003, 2005 Addendum. December, 2005

<http://www.chesapeakebay.net/content/publications/cbp_13378.pdf>.

Chesapeake Bay Program Environmental Modeling – Backgrounder

<http://archive.chesapeakebay.net/pubs/backgrounder_CBP_Models.pdf>.

Chesapeake Bay Program Monitoring and Analysis Subcommittee Tidal Monitoring and Analysis Workgroup. October 2004. *Chesapeake Bay Program, Analytical Segmentation Scheme, Revisions, Decisions and Rationales 1983-2003*.

<http://www.chesapeakebay.net/content/publications/cbp_13272.pdf>.

ChesapeakeStat. 2015. <<http://www.chesapeakestat.com/overview>>.

Eyes on the Bay. 2016. < <http://eyesonthebay.dnr.maryland.gov>>.

Eskin, R., R. Alden, R. Batiuk, S. Bieber, S. Brunenmeister, C. Haywood, R. Hoffman, R. Magnien, and M. Olson. 1993. *Guidance for the Analysis of Water Quality Trends in Chesapeake Bay*. Chesapeake Bay & Watershed Management Administration, Maryland Department of the Environment (MDE): Baltimore, MD. <<http://www.dnr.state.md.us/irc/docs/00011539.pdf>>.

Lyerly, C.M., A.L. Hernández Cordero, K.L. Foreman, S.W. Phillips, W.C. Dennison (eds.). 2014. *New Insights: Science-based evidence of water quality improvements, challenges, and opportunities in the Chesapeake* < http://ian.umces.edu/pdfs/ian_report_438.pdf>.

Magnien, R.E, D.K. Austin, and B.D. Michael. 1993. *Chemical/Physical Properties Component: Level I Data Report (1984-1991)*. Maryland Department of the Environment (MDE): Baltimore, MD. <<http://www.dnr.state.md.us/irc/docs/00016315.pdf>>. (50MB).

Maryland's Tributary Strategy Statewide Implementation Plan (DNR). 2008. *Maryland Tributary Teams - Annual Report 2000*. <<http://www.dnr.state.md.us/irc/docs/00013238.pdf> >.

Maryland Department of Natural Resources (DNR). 2012. *Choptank, Little Choptank and Honga Rivers Water Quality and Habitat Assessment* <<http://eyesonthebay.dnr.maryland.gov/eyesonthebay/documents/ChoptankSummaryWQandHAssessment2012.pdf>>.

Maryland Department of Natural Resources (DNR). 2013. *Choptank and Little Choptank Rivers Water Quality and Habitat Assessment Overall Condition 2010-2012* <<http://eyesonthebay.dnr.maryland.gov/eyesonthebay/documents/ChoptankLittleChoptankupdatesummary2014.pdf> >.

Maryland Department of Natural Resources (DNR). 2014. *Choptank and Little Choptank Rivers Water Quality and Habitat Assessment Overall Condition 2011-2013* <<http://eyesonthebay.dnr.maryland.gov/eyesonthebay/documents/ChoptankLittleChoptankupdatesummary2014.pdf> >.

Maryland Department of Natural Resources (DNR). 2015. *Choptank Basin Rivers Water Quality and Habitat Assessment Overall Condition 2012-2014*. <<http://eyesonthebay.dnr.maryland.gov/eyesonthebay/documents/ChoptankLittleChoptankupdatesummary2015.pdf>>.

Maryland Department of Natural Resources (DNR). 2012. *Lower Eastern Shore Water Quality and Habitat Assessment* <<http://eyesonthebay.dnr.maryland.gov/eyesonthebay/documents/LowerEasternShoreWQandHAssessment2012.pdf>>.

Maryland Department of Natural Resources (DNR). 2013. *Lower Eastern Shore Water Quality and Habitat Assessment Overall Condition 2010-2012* <<http://eyesonthebay.dnr.maryland.gov/eyesonthebay/documents/LowerEasternShoreupdatesummary2013.pdf>>.

Maryland Department of Natural Resources (DNR). 2014. *Lower Eastern Shore Water Quality and Habitat Assessment Overall Condition 2011-2013* <<http://eyesonthebay.dnr.maryland.gov/eyesonthebay/documents/LowerEasternShoreupdatesummary2014.pdf> >.

Maryland Department of Natural Resources (DNR). 2014. *Lower Eastern Shore Water Quality and Habitat Assessment Overall Condition 2012-2014* <<http://eyesonthebay.dnr.maryland.gov/eyesonthebay/documents/LowerEasternShoreupdatesummary2015.pdf>>.

Maryland Department of Natural Resources (DNR). 2012. *Lower Western Shore Water Quality and Habitat Assessment*
<<http://eyesonthebay.dnr.maryland.gov/eyesonthebay/documents/LowerWesternShoreWQandHAssessment2012.pdf>>.

Maryland Department of Natural Resources (DNR). 2013. *Lower Western Shore Water Quality and Habitat Assessment Overall Condition 2010-2012*
<<http://eyesonthebay.dnr.maryland.gov/eyesonthebay/documents/LowerWesternShoreupdatesummary2013.pdf>>.

Maryland Department of Natural Resources (DNR). 2014. *Lower Western Shore Water Quality and Habitat Assessment Overall Condition 2011-2013*
<<http://eyesonthebay.dnr.maryland.gov/eyesonthebay/documents/LowerWesternShoreupdatesummary2014.pdf>>.

Maryland Department of Natural Resources (DNR). 2015. *Lower Western Shore Water Quality and Habitat Assessment Overall Condition 2012-2014*
<<http://eyesonthebay.dnr.maryland.gov/eyesonthebay/documents/LowerWesternShoreupdatesummary2015.pdf>>.

Maryland Department of Natural Resources (DNR). 2012. *Patapsco and Back Rivers Water Quality and Habitat Assessment*
<<http://eyesonthebay.dnr.maryland.gov/eyesonthebay/documents/PatapscoandBackRiverWQandHAssessment2012.pdf>>.

Maryland Department of Natural Resources (DNR). 2013. *Patapsco River and Back River Water Quality and Habitat Assessment Overall Condition 2010-2012*
<<http://eyesonthebay.dnr.maryland.gov/eyesonthebay/documents/PatapscoandBackRiverupdatesummary2013.pdf>>.

Maryland Department of Natural Resources (DNR). 2014. *Patapsco River and Back River Water Quality and Habitat Assessment Overall Condition 2011-2013*
<<http://eyesonthebay.dnr.maryland.gov/eyesonthebay/documents/PatapscoBackRiverupdatesummary2014.pdf>>.

Maryland Department of Natural Resources (DNR). 2015. *Patapsco River and Back River Water Quality and Habitat Assessment Overall Condition 2012-2014*
<<http://eyesonthebay.dnr.maryland.gov/eyesonthebay/documents/PatapscoAndBackRiveUpdateSummary2015.pdf>>.

Maryland Department of Natural Resources (DNR). 2013. *Patuxent River Water Quality and Habitat Assessment*
<http://eyesonthebay.dnr.maryland.gov/eyesonthebay/documents/Patuxent_WQ_and_H_Assessment_2013.pdf>.

Maryland Department of Natural Resources (DNR). 2013. *Patuxent River Water Quality and Habitat Assessment Overall Condition 2010-2012*

<<http://eyesonthebay.dnr.maryland.gov/eyesonthebay/documents/PatuxentRiverupdatesummary2013.pdf>>
>.

Maryland Department of Natural Resources (DNR). 2014. *Patuxent River Water Quality and Habitat Assessment Overall Condition 2011-2013*

<<http://eyesonthebay.dnr.maryland.gov/eyesonthebay/documents/PatuxentRiverupdatesummary2014.pdf>>
>.

Maryland Department of Natural Resources (DNR). 2015. *Patuxent River Water Quality and Habitat Assessment Overall Condition 2012-2014*

<<http://eyesonthebay.dnr.maryland.gov/eyesonthebay/documents/PatuxentRiverupdatesummary2015.pdf>>
>.

Maryland Department of Natural Resources (DNR). 2013. *Potomac River Water and Habitat Quality Assessment*

<http://eyesonthebay.dnr.maryland.gov/eyesonthebay/documents/Potomac_WQ_and_H_Assessment_2013.pdf>.

Maryland Department of Natural Resources (DNR). 2013. *Potomac River Water Quality and Habitat Assessment Overall Condition 2010-2012*

<<http://eyesonthebay.dnr.maryland.gov/eyesonthebay/documents/PotomacRiverupdatesummary2013.pdf>>
>.

Maryland Department of Natural Resources (DNR). 2014. *Potomac River Water Quality and Habitat Assessment Overall Condition 2011-2013*

<<http://eyesonthebay.dnr.maryland.gov/eyesonthebay/documents/PotomacRiverupdatesummary2014.pdf>>
>.

Maryland Department of Natural Resources (DNR). 2015. *Potomac River Water Quality and Habitat Assessment Overall Condition 2012-2014*

<<http://eyesonthebay.dnr.maryland.gov/eyesonthebay/documents/PotomacRiverupdatesummary2015.pdf>>
>.

Maryland Department of Natural Resources (DNR). 2012. *Upper Eastern Shore Basin Water Quality and Habitat Assessment*

<<http://eyesonthebay.dnr.maryland.gov/eyesonthebay/documents/UpperEasternShoreWQandHAssessment2012.pdf>>.

Maryland Department of Natural Resources (DNR). 2013. *Upper Eastern Shore Basin Water Quality and Habitat Assessment Overall Condition 2010-2012*

<<http://eyesonthebay.dnr.maryland.gov/eyesonthebay/documents/UpperEasternShoreupdatesummary2013.pdf>>.

Maryland Department of Natural Resources (DNR). 2014. *Upper Eastern Shore Basin Water Quality and Habitat Assessment Overall Condition 2011-2013*

<<http://eyesonthebay.dnr.maryland.gov/eyesonthebay/documents/UpperEasternShoreupdatesummary2014.pdf>>.

Maryland Department of Natural Resources (DNR). 2015. *Upper Eastern Shore Basin Water Quality and Habitat Assessment Overall Condition 2012-2014*

<<http://eyesonthebay.dnr.maryland.gov/eyesonthebay/documents/UpperEasternShoreupdatesummary2015.pdf>>.

Maryland Department of Natural Resources (DNR). 2012. *Upper Western Shore Basin Water Quality and Habitat Assessment*

<<http://eyesonthebay.dnr.maryland.gov/eyesonthebay/documents/UpperWesternShoreWQandHAssessment2012.pdf>>.

Maryland Department of Natural Resources (DNR). 2013. *Upper Western Shore Water Quality and Habitat Assessment Overall Condition 2010-2012*

<<http://eyesonthebay.dnr.maryland.gov/eyesonthebay/documents/UpperWesternShoreupdatesummary2013.pdf>>.

Maryland Department of Natural Resources (DNR). 2014. *Upper Western Shore Water Quality and Habitat Assessment Overall Condition 2011-2013*

<<http://eyesonthebay.dnr.maryland.gov/eyesonthebay/documents/UpperWesternShoreupdatesummary2014.pdf>>.

Maryland Department of Natural Resources (DNR). 2015. *Upper Western Shore Water Quality and Habitat Assessment Overall Condition 2012-2014*

<<http://eyesonthebay.dnr.maryland.gov/eyesonthebay/documents/UpperWesternShoreupdatesummary2015.pdf>>.

Maryland Department of Natural Resources (DNR). 2007. *Maryland Tributary Strategy Choptank Basin Summary Report for 1985-2005 Data*. <<http://www.dnr.state.md.us/irc/docs/00015905.pdf>>.

Maryland Department of Natural Resources (DNR). 2007. *Maryland Tributary Strategy Lower Eastern Shore Basin Summary Report for 1985-2005 Data*. <<http://www.dnr.state.md.us/irc/docs/00015910.pdf>>.

Maryland Department of Natural Resources (DNR). 2007. *Maryland Tributary Strategy Lower Potomac River Basin Summary Report for 1985-2005 Data*. <<http://www.dnr.state.md.us/irc/docs/00015903.pdf>>.

Maryland Department of Natural Resources (DNR). 2007. *Maryland Tributary Strategy Lower Western Shore Basin Summary Report for 1985-2005 Data*. <<http://www.dnr.state.md.us/irc/docs/00015908.pdf>>.

Maryland Department of Natural Resources (DNR). 2007. *Maryland Tributary Strategy Middle Potomac River Basin Summary Report- 1985-2005 Data*. <<http://www.dnr.state.md.us/irc/docs/00015902.pdf>>.

Maryland Department of Natural Resources (DNR). 2007. *Maryland Tributary Strategy Patapsco/Back Basin Summary Report for 1985-2005 Data*. <<http://www.dnr.state.md.us/irc/docs/00015906.pdf>>.

Maryland Department of Natural Resources (DNR). 2007. *Maryland Tributary Strategy Patuxent River Basin Summary Report for 1985-2005 Data*. <<http://www.dnr.state.md.us/irc/docs/00015901.pdf>>.

Maryland Department of Natural Resources (DNR). 2007. *Maryland Tributary Strategy Upper Eastern Shore Basin Summary Report for 1985-2005 Data*. <<http://www.dnr.state.md.us/irc/docs/00015909.pdf>>.

Maryland Department of Natural Resources (DNR). 2007. *Maryland Tributary Strategy Upper Potomac River Basin Summary Report for 1985-2005 Data*. <<http://www.dnr.state.md.us/irc/docs/00015904.pdf>>.

Maryland Department of Natural Resources (DNR). 2007. *Maryland Tributary Strategy Upper Western Shore Basin Summary Report for 1985-2005 Data*. <<http://www.dnr.state.md.us/irc/docs/00015907.pdf>>.

U.S. Environmental Protection Agency (EPA). 2008. *Ambient Water Quality Criteria for Dissolved Oxygen, Water Clarity and Chlorophyll a for the Chesapeake Bay and Its Tidal Tributaries, 2008 Technical Support for Criteria Assessment Protocols Addendum* September 2008. EPA 903-R-08-001, CBP/TRS 290-08. Region III Chesapeake Bay Program Office, Annapolis, MD. <http://www.chesapeakebay.net/content/publications/cbp_47637.pdf>.

U.S. Environmental Protection Agency (EPA). 2005. *Chesapeake Bay Program Analytical Segmentation Scheme - Revisions, Decisions and Rationales 1983-2003, 2005 Addendum* <http://www.chesapeakebay.net/content/publications/cbp_13378.pdf>.

U.S. Environmental Protection Agency (EPA). 1997. *Chesapeake Bay Nutrient Reduction Progress & Future Directions: Nutrient Reduction Reevaluation Summary Report*. Chesapeake Bay Program, October 1997. CBP/TRS 189/97. <http://www.chesapeakebay.net/content/publications/cbp_12305.pdf>.

U.S. Environmental Protection Agency (EPA). 1996. *Recommended Guidelines for Sampling and Analysis in the Chesapeake Bay Monitoring Program*. Chesapeake Bay Program, August 1996. CBP/TRS 148/96; EPA 903-R-96-006. <http://www.chesapeakebay.net/content/publications/cbp_13101.pdf>.

U.S. Environmental Protection Agency (EPA). 2008. *The State of the Chesapeake Bay and the Watershed: A Progress Report January 3, 2008*. Chesapeake Bay Program. <<http://www.chesbay.us/Presentations/January08/CBC%20Ches%20State%20of%20the%20Bay%20Update.pdf>>.

U.S. Environmental Protection Agency (EPA). 2010. *Chesapeake Bay Coordinated Split Sample Program Implementation Guidelines, December 2010*. Chesapeake Bay Program: Annapolis, MD. <http://archive.chesapeakebay.net/pubs/quality_assurance/CSSP_Guidelines_12-17-10.pdf>.

U.S. Environmental Protection Agency (EPA). 1983. *Chesapeake Bay: A Framework for Action*. Chesapeake Bay Program: Annapolis, MD. 186 p. <http://www.chesapeakebay.net/content/publications/cbp_12405.pdf>.

U.S. Environmental Protection Agency (EPA). 1983. *Chesapeake Bay: A Profile of Environmental Change*. <http://www.chesapeakebay.net/content/publications/cbp_13260.pdf>.

Welch, P.S. 1948. Chapter 11 in *Limnological Methods*. Blakiston: Philadelphia, PA. <<http://www.worldcat.org/title/limnological-methods/oclc/962656>>.

APPENDIX I

MARYLAND DEPARTMENT OF NATURAL RESOURCES CHESAPEAKE BAY WATER QUALITY MONITORING PROGRAM

WATER COLUMN SAMPLING AND SAMPLE PROCESSING PROCEDURES

I. DEPTH SAMPLING PROTOCOLS

A. Hydrolab/YSI Depth Sampling Protocols (Mainstem and Tributary)

1. Take readings of temperature, specific conductance, salinity, dissolved oxygen, and pH at 0.5 m, 1.0 m, 2.0 m and 3.0 m. Thereafter, take readings at a minimum of 2.0 m intervals (subject to conditions specified in A.2. below) and at the bottom sample depth. Mainstem bottom sample depth is equal to the nearest whole meter that is at least one meter above the total depth. Tributary bottom sample depth is equal to the total depth minus one meter (not rounded).
2. If the change in DO exceeds 1.0 mg/l OR if the change in specific conductance equals or exceeds 1,000 micromhos/cm over any 2.0 m interval, take readings at the 1.0 m interval between these two readings. Take readings at 1.0 m intervals for total depths less than or equal to 10.0 m.
3. If the above pycnocline (AP) or below pycnocline (BP) sample depth has not been sampled for *in situ* parameters, obtain readings at this depth.
4. At a minimum, take readings at 0.5, 1.0, 2.0, 3.0 m, bottom, and every odd-numbered whole meter depth.

B. Grab Sampling Depth Protocols

1. At stations where two depths are sampled, take collections at:
 - a. 0.5 m below surface.
 - b. 1.0 m above bottom (total depth) to nearest 1.0 m that is at least one full m from the bottom (mainstem).
 - c. 1.0 m above bottom (trib).

NOTES: If total station depth is ≤ 1.5 m, take bottom sample at 0.5 m. Exercise caution when taking bottom samples; if disturbed bottom sediments appear to have been included in a sample, resample after sediment has settled or take sample slightly higher in the water column. If resampling occurs, note this on the field sheet.

2. ***Pycnocline Exists***: At stations where 4 depths are sampled and a pycnocline exists (see Section C, below), take collections at:

- a. 0.5 m below surface.
- b. 1.5 m above upper boundary of pycnocline.
- c. 1.5 m below lower boundary of pycnocline.
- d. 1.0 m above bottom to nearest 1.0 m that is at least one full m from bottom (mainstem).
- e. 1.0 m above bottom (trib).

NOTE: Above pycnocline depth and below pycnocline depth grab samples are collected at the following stations: CB2.2, CB3.1, CB3.2, CB3.3C, CB4.1C, CB4.1E, CB4.2C, CB4.3C, CB4.3E, CB4.4, CB5.1, CB5.2, CB5.3, EE1.1, EE2.1, EE3.1, EE3.2, ET4.2, ET5.2, LE2.2, LE2.3, RET2.4 and WT5.1.

Grab samples on the Patuxent Boat survey are collected at four depths at seven other sites. In addition to surface and bottom water samples, upper mid-water samples (designated as AP) are collected at 3 meters depth. At stations RET1.1 and TF1.5, lower mid-water samples (designated as BP) are collected at 6 meters. Lower mid-water samples are collected at 8 meters at station CB5.1W. Lower mid-water samples are collected at 9 meters at stations LE1.1 and LE1.4. At stations LE1.2 and LE1.3 lower mid-water samples are collected at the depth of 12 meters.

Grab samples on the Potomac Boat survey are collected at three depths at five stations. In addition to surface and bottom water samples, mid-depth samples (M) are collected at 4.6 meters at stations RET 2.2, TF2.4, TF 2.3 and TF 2.2. The station TF 2.1 mid-depth sample is collected at 9.1 meters.

3. ***No Discernable Pycnocline***: At stations where 4 depths are sampled and there is no discernable pycnocline (see Section C, below), take collections at:

- a. 0.5 m below surface.
- b. at closest profile depth one third the distance from the surface to the bottom.
- c. at closest profile depth two thirds the distance from the surface to the bottom.
- d. 1.0 m above bottom (total depth) to nearest 1.0 m that is at least one full m from the bottom (mainstem).
- e. 1.0 m above bottom (tributary).

C. Pycnocline Determination (Only for Stations Sampled at four depths)

The pycnocline is a region in which the water density changes appreciably with increasing depth and thus forms a layer of much greater stability than is provided by overlying surface waters.

1. The pycnocline Calculated Threshold Value (CTV) is used to determine the

boundaries of the pycnocline and to calculate the depths at which grab samples should be collected. The pycnocline Calculated Threshold Value (CTV) is derived using the equation below.

$$CTV = \frac{C_b - C_s}{D_b - D_s} \times 2$$

Where:

- C_b = bottom conductivity (micromhos/cm),
- C_s = surface conductivity (micromhos/cm),
- D_b = depth of bottom conductivity measurement (m),
- D_s = depth of surface conductivity measurement (m),
- CTV = calculated threshold value (micromhos/cm)

- ex. bottom conductivity: 15800 micromhos/cm
 surface conductivity: 9500 micromhos/cm
 depth of bottom conductivity measurement: 14.6 m
 depth of surface conductivity measurement: 0.5 m

$$CTV = \frac{15800 - 9500}{14.6 - 0.5} \times 2 = 893.6 \text{ micromhos/cm}$$

NOTE: micromhos/cm is equivalent to microsiemens/cm ($\mu\text{S/cm}$)

2. If the Calculated Threshold Value is greater than 500 micromhos/cm, a pycnocline exists with boundaries at the first and last depths where the change in conductivity is greater than the CTV. For example, continuing with the CTV value: 893.6 derived in the example calculation above, and evaluating conductivity readings moving up in the water column from the bottom, the lower boundary of the pycnocline occurs at first depth where the change in conductivity from that measured at the preceding depth exceeds 893.6. Moving upward in the water column, the upper boundary of the pycnocline occurs at last depth where the change in conductivity from that measured at the preceding depth exceeds 893.6. Samples will be taken as described above in section B. 2.

NOTE: In the rare cases when the sample is theoretically 'below the bottom' or 'above the surface', use following procedures. If the below pycnocline (BP) sample is determined to be below the bottom sample, collect the BP sample at the bottom sample depth. If the above pycnocline (AP) sample is determined to be above the surface sample, collect the AP sample at 0.5 m.

3. Take samples as described in section B. 3. (No Discernable Pycnocline), above, if either of the following two conditions are true:
 - a. the CTV is less than 500 micromhos/cm.
 - b. the CTV is equal to or greater than 500 micromhos/cm BUT no depth interval exceeds that CTV.

NOTES: Upper and lower boundaries of the pycnocline may be the same point. If this is the case, collect the Above Pycnocline sample 1.5 m above the upper pycnocline limit and collect the Below Pycnocline sample 1.5 m below the lower pycnocline limit.

D. Hydrogen Sulfide Protocols

1. For the mainstem only, when there is an odor of hydrogen sulfide present in the bottom sample or the below pycnocline sample, perform a Hach Kit test for hydrogen sulfide presence on the bottom and/or below pycnocline sample(s).
2. Immediately upon collection of the sample that meets the requirements in D. 1. above, transfer a portion of sample from the sample bottle to the 25 ml Hach Test glass container (from the Hach Hydrogen Sulfide Test Kit, Model HS-6), for hydrogen sulfide determination.
3. Immediately perform test for H₂S presence following instructions in Hach Hydrogen Sulfide Test Kit. Record results on the Cruise Report.

E. Secchi Depth

Measure water transparency using Secchi disc. Determine Secchi depth in meters to the nearest 0.1 meter using a 20-cm standard Secchi disc lowered into the water column with a calibrated rope. Make observations on the shady side of the boat. Do not wear sunglasses while taking a Secchi reading.

F. Photosynthetic Active Radiation (PAR)

PAR readings (in $\mu\text{Moles/square meter/second}$) are taken in the field in order to calculate a light attenuation coefficient. Take PAR measurements with a LICOR quantum meter (Model LI-1400 Data Logger) with an attached underwater probe (Model LI-192SA). The probe is a flat, upwardly-directed probe. Each underwater reading is paired with a reading from a flat, upwardly-directed ambient light probe (model LI-190SA).

Begin a vertical profile of light penetration by taking an initial reading with the underwater sensor just below the surface of the water (0.1 m). Take subsequent measurements at either 0.25-m or 0.50-m intervals depending on the turbidity of the water column, (taking shallower measurements in more turbid water). Continue to take readings until a value less than ten percent (10 %) of the surface reading (0.1 m) is

attained. Once the readings stabilize, allow at least five readings to flash on the display before recording the data reading for a specific depth. Record in the data logger the mean of the previous five readings that appear on the instrument display. Alternatively, the mean value may be recorded on the field datasheet. Underwater water and ambient readings must be recorded simultaneously. Be sure to collect additional profile readings if the ambient readings decreased significantly from the starting ambient reading.

The light measurements made for each profile are log-scale regressed against depth to determine the compensation depth, i.e., the depth of penetration of one percent (1 %) of the surface PAR. The compensation depth is used in computing the integrated carbon production for that water column. When light profiles are not available, the secchi disk depth is used to calculate the compensation depth. Over the study period, 1984-1996, a regression has been made between the secchi depth and the compensation depth for the same water column (for those stations where both secchi data and LICOR data are taken). By using this regression, a compensation depth can be estimated from a secchi depth.

The following table lists the parameters measured and the associated qualifiers to be recorded for light attenuation:

FIELD	DESCRIPTION
SOURCE (PK, FK)	Code identifying agency or contractor that measured the data
PROJECT (PK, FK)	Agency monitoring project code
STATION (PK, FK)	CBP station name
SAMPLE_DATE (PK)	Date on which the PAR readings were taken
SAMPLE_TIME (PK)	Time at which the PAR readings were taken
DEPTH (PK)	Depth at which the PAR readings were taken (meters)
EPAR_S	PAR reading ($\mu\text{M}/\text{m}^2/\text{s}$) taken at the boat just before or during the measurement of PAR readings at depth
EPARU_Z	PAR reading ($\mu\text{M}/\text{m}^2/\text{s}$) taken at depth (up sensor)
UNITS	Units for PAR ($\mu\text{M}/\text{m}^2/\text{s}$)
METHOD	Method code identifying the field measurement procedure
COMMENTS	Comments related to the collection of PAR readings

II. SAMPLE COLLECTION

- A. Lower submersible pump to desired depth.
- B. Allow hose to flush completely before taking sample (flush time is pump dependent).
- C. Rinse pre-marked sample container (plastic bottle) and cap three times with sample water.
- D. Collect sample, cap the bottle, and begin water sample processing and appropriate storage/preservation.
- E. Any time a field duplicate is required (whenever indicated on the station lab data sheet), follow the procedures in the section "Split-sample collection method for field duplicates".
- F. Enter all identifying information pertinent to samples collected on the lab and field sheets.

III. SPLIT-SAMPLE COLLECTION METHOD FOR FIELD DUPLICATES

- A. Samples for field duplicates are generated approximately one for every 20 samples collected.
- B. Collect sample as in section II. A and II. B above.
- C. Rinse duplicate collection container three times and fill with sample water.

NOTE: Collection container must be large enough to generate two complete samples. If more than one gallon of sample is needed for samples, fill a plastic bucket (2.5 to 5 gallon) with sample water and draw all samples from the bucket, taking care to maintain a homogeneous mixture as water is drawn from the duplicate container.

- D. Begin water sample processing and appropriate storage/preservation.
- E. Enter all identifying information pertinent to samples collected on lab and field sheets.

NOTE: Lab and field sheets must have a replicate number entered for each duplicate generated.

IV. FILTRATION, PROCESSING AND STORAGE OF CHLOROPHYLL SAMPLES

- A. For every depth sampled, clean bell and frit with deionized water (DI-H₂O; stored in a high density polyethylene container) generated at the Field Office. Set up bell and frit for filtering. Ensure that there is a trap in line between the manifold and the vacuum source.

B. Place a Whatman GF/F glass fiber filter pad (pore size = 0.7 μm) on the filter frit. When handling the pad, use clean forceps.

C. Mix sample thoroughly by agitating plastic sample container vigorously, then rinse graduated cylinder three times with sample.

D. Fill graduated cylinder with sample and filter desired volume through filtration unit. Keep the vacuum below 10 inches of Hg. Filter sufficient volume of sample (100 - 1500 ml) to solidly color the filter pad. Do not suck the filter dry. In order to avoid cell damage, decrease the amount of vacuum as the final volume approaches the level of the filter and release the vacuum as the last of the water is pulled through the pad. Record the total volume filtered.

E. Add approximately 1 ml of MgCO_3 suspension (Laboratory grade from Fisher Scientific prepared in a 1.0 g MgCO_3 to 100 ml of DI- H_2O ratio) to the last 50 ml of sample in the filtration bell. This is equivalent to less than 1 mg of MgCO_3 per 15 ml extract.

NOTE: Filtrate for nutrient analysis should not be saved from this filtration.

F. Remove filter pad with forceps, fold filter in half with sample inside, place in pre-marked foil square, and carefully fold square in thirds, horizontally and vertically, to seal filter inside. Be sure forceps do not touch sample residue on the filter pads, because the sample will adhere to the forceps.

G. Be sure that foil square is marked with date, station, sample layer code, volume of sample filtered, sample number, and "CHLA".

H. Place sample FOIL into pre-marked zip-lock plastic bag. Store bag of chlorophyll samples in Research Vessel freezer for mainstem samples or an ice chest for tributary samples. If samples are stored on ice, place in freezer on return to Field Office.

I. Record sample identifier, date, volume filtered (L), depth (m), layer, start time, end time, study code, submitter code, data category code, field scientist sign off, and replicate number, if necessary, on chlorophyll calculation sheet. This sheet is submitted to the laboratory with the samples.

NOTE: Filter pad with chlorophyll sample should be exposed to as little direct sunlight as possible. Store filter pad in foil as soon as possible.

NOTE: A lab replicate pad (different from the field replicate) is generated every 10 samples. Filter the exact same volume as the first pad. Place the second pad alongside the first pad in to foil. The label on the foil will indicate "2 pads" to denote when to generate a replicate pad.

V. FILTRATION, PROCESSING AND STORAGE FOR PARTICULATE FRACTIONS (PARTICULATE P, C, N AND TOTAL SUSPENDED SOLIDS)

A. Processing and storage - PC, PN:

For each depth sampled, thoroughly clean all bells and frits with DI-H₂O, set up filter apparatus, filters (two pre-combusted 25 mm GF/F filters, pore size = 0.7 μm), and bells for filtering. Filter 10-300 ml through each filter. Filter enough of the sample to leave noticeable color on the filter pad. Make sure filter is sucked dry. Using forceps, fold each filter in half. Place both filters in a foil square labeled with date, PC/PN-CBL sample number, station, sample layer, and volume filtered. Fold as described in IV.F. and then place folded foil in zip-lock bag, and put in freezer (large boats) or on ice (small boats).

B. Processing and storage - PP, TSS:

For each depth sampled, thoroughly clean all glassware with DI-H₂O. Set up one flask, filter (one pre-weighed and numbered 47 mm GF/F filter placed with the pad number facing down), and bell for filtering. After rinsing a graduated cylinder three times with sample water, measure 50 - 300 ml of sample into the filter bell. Use the filtrate as an equipment rinse and discard. Note amount filtered through the filter. Then filter enough additional (another 50 -400 ml) to leave a noticeable color on the filter pad. Use this filtrate as required for filtered parameter analysis.

After collecting filtrate, make sure filter is sucked dry, and rinse three times with 10 ml rinses of water, sucking dry after each rinse. Using forceps, fold filter in half. Make sure the pad number is clearly legible on one side only and not on the crease. Place filter in a foil square labeled with date, TSS/PP-CBL sample number, station, sample layer, and volume filtered. Fold as described in IV.F. Write sample number on foil with Sharpie permanent marker to facilitate post-combustion sample identification. Place foil square in zip-lock bag, and put in freezer (large boats) or on ice in (small boats).

NOTE: A lab replicate pad (different from the field replicate) is generated every 10 samples. Filter the exact same volume as the first pad. Place the second pad alongside the first pad in to foil. The label on the foil will indicate “2 pads” to denote when to generate a replicate pad.

Ten percent of the filters that CBL supplies for field filtering TSS must be pre-rinsed 3 times with deionized water, dried at 103-105 °C for 1 hour, then weighed, re-dried and reweighed until a constant weight is obtained.

C. Processing and storage - VSS:

VSS samples are collected from the surface and AP samples at pre-determined stations. Thoroughly clean all glassware with DI-H₂O. Set up one flask, filter (1 pre-weighed, pre-combusted and numbered 47 mm GF/F filter), and bell for filtering. The number for the pad is written on the individual Petri dish that the pad came in. You must write this

number on the foil square label and volume sheet. After rinsing a graduated cylinder three times with sample water, measure 50 - 300 ml of sample into the filter bell. Use the filtrate as an equipment rinse and discard. Note amount filtered through the filter. Then filter enough additional (another 50 -400 ml) to leave a noticeable color on the filter pad. You may use this filtrate as required for filtered parameter analysis.

After collecting filtrate, make sure filter is sucked dry, and rinse three times with 10 ml rinses of water, sucking dry after each rinse. Using forceps, fold each filter in half. Place the filter in a foil square labeled with date, VSS-CBL sample number, pad number, station, sample layer, and volume filtered. Fold as described in IV.F. and write sample number on foil with Sharpie permanent marker to facilitate post-combustion sample identification. Place foil square in the TSS/PP zip-lock bag, and put in freezer (large boats) or on ice in (small boats).

VI. FILTRATION, PROCESSING AND STORAGE FOR "DISSOLVED" FRACTIONS (NH₄, NO₂, NO₃, PO₄, Si, TDN, TDP, DOC)

A. This filtrate always comes from particulate phosphorus/TSS filters, section V, above. It is acceptable to use the filtrate from the VSS filtration if more volume is needed. Use GF/F filters, and pre-rinse the filter and flask with at least 50 ml of sample water. The sample must be collected prior to rinsing the pads with DI-H₂O.

B. Processing and storage - NH₄, NO₂ + NO₃, NO₃, PO₄, Si:
Triple rinse, with filtrate, three like-numbered autoanalyzer (AA) vials and caps. Fill approximately 7/8 full, allowing for sample expansion upon freezing. Place the AA vials in a rack in the freezer. A fourth vial is collected for silica at a subset of stations. The silicate vial should be stored at 4 °C in the R/V refrigerator. On small boats, keep all samples iced in a cooler, and then freeze all but silica upon return to Field Office. Place the silica samples in the refrigerator upon return to the Field Office.

NOTE: The number on all vials and tubes is the CBL sample number and should match the number on TSS/PP and PC/PN foil pouches for each particular sample.

C. Processing and storage - TDN, TDP:

Triple rinse test tube, cap, and 10 ml graduated cylinder with filtrate. Be sure the number on test tube corresponds to the number on the vials and sample number. Use 10 ml graduated cylinder to measure EXACTLY 10.0 ml of filtrate. (The 10 ml graduated cylinders will be calibrated annually by the Chesapeake Biological Laboratory.) Shake any remaining rinse water out of the test tube. Pour into pre-rinsed test tube and cap sample, then freeze sample in test tube rack on large boats. On small boats, keep sample on ice in cooler, then freeze upon return to Field Office.

D. Processing and storage - DOC (collected at subset of Bay Tributary and mainstem survey stations): Triple rinse 50 ml test tube and cap with filtrate. Fill the 50 ml test tube 3/4 full with filtrate and cap sample, then freeze in test tube rack. On small boats, keep sample on ice, then freeze at Field Office.

VII. ROUTINE MAINTENANCE OF FILTRATION UNITS AND CONTAINERS FOR MAINSTEM CRUISES AND AFTER RETURNING FROM FIELD

A. After each day's sampling on mainstem cruises, filtration units, flasks, frits and graduated cylinders should be cleaned with a non-phosphorus liquid soap, rinsed with tap water three times, then rinsed with 10% HCl (prepared from concentrated HCL from Fisher Scientific diluted with DI-H₂O), tap rinsed, and finally rinsed three times with DI-H₂O. All open flasks, filtration units and graduated cylinders should then be covered to prevent contamination if filtering is not to begin immediately. The filtration unit used for chlorophyll *a* filters should be washed with soap and rinsed with tap and DI water and not be rinsed with 10 percent HCl.

B. Big boat units are cleaned at the end of each day's sampling. Small boat or land run units are rinsed with DI-H₂O at end of each day's use and cleaned (with acid) weekly, or after processing 20 to 30 samples.

VIII. FIELD FILTERED AND SOURCE WATER BLANKS

A. Mainstem - One field filtered equipment blank will be collected each day. One unfiltered (source water) blank will be collected each day. The filtered equipment blank and source water blank will be collected and submitted at the same time.

B. Tributary- One field filtered equipment blank collected will be each month. One unfiltered (source water) blank will collected each month. The filtered equipment blank and source water blank will be collected and submitted at the same time. The tributary field blanks will rotate through the sampling teams to ensure that all filtering equipment is being evaluated for contamination.

C. Both the Mainstem and Tributary blanks will be analyzed by CBL. If any of the blanks show results greater than the Minimum Detection Limit, MDDNR Field Office staff members will investigate the potential sources of contamination and will assess the significance of the contamination.

APPENDIX II

MARYLAND DEPARTMENT OF NATURAL RESOURCES CHESAPEAKE BAY WATER QUALITY MONITORING PROGRAM

FIELD SHEET AND LAB SHEET- DOCUMENTATION AND PROCEDURES

The following words describe procedures Maryland Department of Natural Resources uses to fill out Field Data Sheets, and Lab Volume Sheets (nutrient, suspended solids and chlorophyll) used for the Chesapeake Bay Mainstem and Tributaries water quality monitoring programs.

Examples of Field Data Sheets: A, B and Patuxent River are located at the end of this appendix. Lab volume sheet, raw and processed mainstem LiCor data are also shown.

Water quality data columns in field data sheets A and B are different from Patuxent Field Data Sheet water quality columns because of differences in how LiCor data are handled. LiCor data are logged on Patuxent Field Data Sheets. LiCor data collected on mainstem surveys are downloaded, stored, processed and submitted separately. Differences between Patuxent Field Sheets and Field Sheets A and B are noted below.

Beginning in 2009, chlorophyll analysis by the Maryland Department of Health and Mental Hygiene ceased and the Chesapeake Bay Laboratory, Nutrient Analytical Services Laboratory began analyzing chlorophyll samples.

Codes used for the water quality monitoring program are listed in Appendix X.

NOTE: Leave blank any boxes on the Field Sheet for which data are not collected.

Field Sheet A:

The Field Sheets are sent along with a Cross Reference Sheet from the Field Office to the Data Management Unit at the DNR Tawes Building. (See Appendix III for information on the Cross Reference Sheet.) The Field Office must provide the following information on the Field Sheet.

1. Sequence Number (boxes 3-9, upper right hand corner)

The following convention has been used to designate the 7-digit sequence number for the mainstem, where YY is last two digits of year, NNN is the cruise number (that year), and SS is the station order for that week's cruise:

MAINSTEM Convention YYNNNSS

For example, sequence number 8401204 is the 12th cruise in 1984 at station 4 for that week's cruise.

The following convention has been used to designate the 7-digit sequence number for the tributary sampling, where YY is last two digits of year, MM is month, T is for tributary, P is for Patuxent, M is for Potomac, C is for CORE, and XX is arbitrary ordering number:

TRIB Convention	YYMMTXX
PXT Convention	YYMMPXX
POT Convention	YYMMMXX
CORE Convention	YYMMCXX

For example, 9603P05 is the fifth field sheet for a March Patuxent cruise in 1996.

2. Sampling Station Number (boxes 10-18)

Enter the appropriate Chesapeake Bay Program station location (e.g. WT5.1, ET5.2) beginning with the box numbered 10. Put only one character (including decimal points) per box.

3. Start Date (boxes 20-25)

Enter the start date beginning with year, then month and then day. Use two numbers each for year, month and day. For example, March 2, 2017 would be entered 170302.

4. Start Time (boxes 27-30)

Enter the start time of the sampling effort at a station location in military time.

5. End Date (boxes 32-37)

If the end date for a particular station is the same as the start date, the end date boxes can be left blank.

6. End Time (boxes 39-42)

Enter the end time of the sampling collection effort at a station location in military time. The end time is the time at the end of *in situ* data collection (meter readings).

7. Number of Samples (boxes 44-45)

Enter the number of samples taken (including duplicates) at the station location. Routinely, there are two to five samples collected at stations for the Chesapeake Bay Monitoring program.

8. Submitter Code (boxes 47-48)

The submitter codes specify the collection group and the lab that will perform the analyses.

9. Data Category Code (boxes 50-51)

The data category codes, which are listed in Appendix X, specify the code for the type of sample being collected. For example, for the Chesapeake Bay Program Main Bay Sampling, the code is 'MB' - Chesapeake Bay Monitoring Sample- MD. Main Bay".

10. Total Depth (M) (boxes 53-55)

Enter the total depth at the station in meters to the nearest 0.1 m for tributary stations and to the nearest 0.5 m for mainstem stations.

11. Study Code (boxes 57-58)

The study codes, which are listed in Appendix X, indicate the type of monitoring program. For example, '01' is the study code for the "Chesapeake Bay Monitoring Program - Main Bay".

12. Sample Method (line #2, box 10)

The sample method codes, which are listed in Appendix X, indicate the sample method used for the sampling effort. For example, '1' is the code for 'Grab Samples'.

Note: If no water samples are collected, the code is '7', (FIELD MEASUREMENTS ONLY).

13. Air Temperature degrees Celsius (line #2, boxes 11-14)

Air temperature is reported in degrees Celsius to the nearest 0.5 degrees. The value is recorded in boxes 12-14. Box 11 is used to indicate whether the temperature is above, below or exactly zero. If the temperature is above zero, write a plus (+) in box 11. If the temperature is below zero, write a minus (-) and leave box 11 blank if the temperature is 0 degrees. If the air temp is a single digit (-/+ 4.0), a zero must be placed in box 12 of the field sheet for example: -04.0.

14. Tide State (line #2, box 18)

Tide state codes are listed in Appendix X. For example, the code 'E' specifies an ebb tide.

15. Weather Code Yesterday (line #2, boxes 20-21)

Enter the code for yesterday's weather in these boxes. The weather codes with their corresponding descriptions are listed in Appendix X. Additional weather information can be included in the comments section if appropriate.

16. Weather Code Today (line #2, boxes 23-24)

Enter the code for current weather (while at station) in these boxes. Additional weather information can be included in the comments section if appropriate.

17. Percent Cloud Cover (line #2, boxes 25-27)

Enter the amount of cloud cover in these boxes. Percent Cloud Cover is reported as values from 000 to 100 percent. Numbers must be **right** justified, e.g., __ 5 (not 5 __).

18. Wind Direction (line #2, boxes 28-30)

Record wind direction using the codes:

N - Northerly direction
 S - Southerly direction
 E - Easterly direction
 W - Westerly direction

Record wind direction in boxes 28-30 using up to three letters to designate the prevailing conditions. An example of wind direction would be 'north by north east' and the codes in boxes 28-30 would be 'NNE'. If only one or two letters are needed to designate the conditions, use the boxes beginning with box #28 for the codes. Letters must be **left** justified, e.g., S W (**not** S W)

19. Wind Velocity (knots) (line #2, boxes 31-32, 33-34)

Record wind velocity in knots in boxes 31-32, 33-34. Record the minimum (or lower range) velocity in boxes 31-32; record the maximum (or upper range) velocity in boxes 33-34. For example, if the wind is blowing from 7 to 10 knots, the minimum wind velocity is '07' and the maximum wind velocity is '10'. If only one number is needed to designate the wind velocity conditions, enter the identical numbers in both the boxes for minimum velocity as well as in the boxes for maximum velocity. Beaufort wind force scale values may be used when recording wind velocity. 01-03, 04-06, 07-10, 11-16, 17-21, 22-27, and 28-33.

number	Wind speed				Mean wind speed (kt / km/h / mph)	Description	Wave height		Sea conditions	Land conditions
	kt	km/h	mph	m/s			m	ft		
0	0	0	0	0-0.2	0 / 0 / 0	Calm	0	0	Flat.	Calm. Smoke rises vertically.
1	1-3	1-6	1-3	0.3-1.5	2 / 4 / 2	Light air	0.1	0.33	Ripples without crests.	Wind motion visible in smoke.
2	4-6	7-11	4-7	1.6-3.3	5 / 9 / 6	Light breeze	0.2	0.66	Small wavelets. Crests of glassy appearance, not breaking	Wind felt on exposed skin. Leaves rustle.
3	7-10	12-19	8-12	3.4-5.4	9 / 17 / 11	Gentle breeze	0.6	2	Large wavelets. Crests begin to break; scattered whitecaps	Leaves and smaller twigs in constant motion.
4	11-16	20-29	13-18	5.5-7.9	13 / 24 / 15	Moderate breeze	1	3.3	Small waves.	Dust and loose paper raised. Small branches begin to move.
5	17-21	30-39	19-24	8.0-10.7	19 / 35 / 22	Fresh breeze	2	6.6	Moderate (1.2 m) longer waves. Some foam and spray.	Smaller trees sway.
6	22-27	40-50	25-31	10.8-13.8	24 / 44 / 27	Strong breeze	3	9.9	Large waves with foam crests and some spray.	Large branches in motion. Whistling heard in overhead wires. Umbrella use becomes difficult.
7	28-33	51-62	32-38	13.9-17.1	30 / 56 / 35	Near gale	4	13.1	Sea heaps up and foam begins to streak.	Whole trees in motion. Effort needed to walk against the wind.

20. Secchi (M) (line #2, boxes 35-38)

Record Secchi depth in meters to the nearest 0.1 meter.

21. Flow Value (line#2, boxes 39-46)

Note that flow is not recorded in regular scientific notation, but is recorded as follows. Box #39 is the flow basis code, where:

- 1 = measured in cubic feet per second (CFS)
- 2 = estimated in cubic feet per second (CFS)
- 3 = measured in million gallons per second (MGS)
- 4 = estimated in million gallons per second (MGS)
- 5 = measured in gallons per day (GPD)
- 6 = estimated in gallons per day (GPD)

Boxes 40-44 are for the five-digit mantissa and box 45 is for the exponential value in base 10. These boxes are to be left blank at boat or other stations where flow is not recorded.

For example, estimated flow $4.5_{\text{cfs}} = 2.450001$, where "2" indicates that the flow is estimated in cubic feet per second, "45000" indicates that the mantissa is 4.5000, and "1" indicates multiply the mantissa by 10^1 .

The final box, #46, is for greater or less than (G or L).

Note: Flow value is not a required parameter and is seldom measured.

22. Senior Scientist (line #2, boxes 47-49)

The three initials of the senior scientist (the scientist in charge of the sampling effort for that day) are entered in these boxes. If the scientist has only 2 initials the letters are flush left with box 49 empty.

23. DO Method (line #3, box 50)

The codes for the dissolved oxygen (DO) methods are listed in Appendix XI. Method code values currently used are: 'H' for Hydrolab Clark Cell; 'L' for Hydrolab LDO; and 'R' for YSI ROX.

24. Equipment Set Unit # (line #3, boxes 51-52)

The numbers assigned to equipment packages is recorded in these boxes.

25. Probe Number (line #3, boxes 53-54)

Enter the Hydrolab or YSI probe number in these boxes. If using spares, enter the same equipment letter in probe number box and record spare number in comments boxes.

The text of the label over boxes 53-54 on the field sheets used on Patuxent River project is "LiCor Number" instead of "Probe Number". (See Patuxent field sheet example at the end of this appendix).

26. Flow/Tide Unit Number (line #3, boxes 55-56)

Enter in boxes 55-56 the number of the meter used to measure the flow value. These boxes should be left blank if flow was not recorded for the station.

The text of the label over boxes 55-56 on the field sheets used on Patuxent River project is “LiCor Method” instead of “Flow/Tide Unit Number”. (See Patuxent field sheet example at the end of this appendix).

27. Wave Height (M) (line #3, boxes 57-59)

Wave height is recorded in meters.

Values used for wave heights are

0.00 m=flat calm	0.09 m= slight ripple	0.20 m= ripple-1 foot
0.40 m= 1-2 feet	1.00 m 2-4 feet	1.5 m 4-6 feet

28. Upper Pycnocline Limit (M) (line #3, boxes 60-62)

The calculated value for the upper pycnocline limit is recorded in meters and is entered in these boxes. If no pycnocline exists, leave these boxes blank.

29. Lower Pycnocline Limit (M) (line #3, boxes 63-65)

The calculated value for the lower pycnocline limit is recorded in meters and is entered in these boxes. If no pycnocline exists, leave these boxes blank.

30. Scientist Signoff (line #3, boxes 66-68)

A DATA SHEET WITH NO SCIENTIST SIGNOFF WILL NOT BE SENT TO THE DATA ENTRY SERVICE.

The scientist who checked over the field sheet for:

- the correct codes
- the correct date
- the correct start time and end time
- the correct sampling station number
- reasonable values for the parameters

the values for the parameters are entered on the sheet properly enters his/her initials in these boxes.

Ideally, the individual who initiates the signoff is a separate individual from the one who enters the values on the data sheet. This process of using two separate individuals whenever possible, one to enter the values onto the sheet and one to check over the values that are entered, can help minimize transcription errors and correct aberrations in protocol. However, when a scientist works alone, the same scientist who enters the values checks the sheets before leaving the station.

31. Comments (beginning on line #3 - #5)

Any comments that are necessary to fully describe the sampling effort should be entered in the Comment section. Use one box for each character, decimal point, or period.

32. Replicate Number (line #6, box 11).
Patuxent River Survey Replicate Number (line #6, box 10)

If the values for specific conductance, water temperature, DO, etc. are repeated for a single depth and are entered on the field sheet, indicate this by entering the replicate number (from 2 to 9) in these boxes. A blank in line #6, box 11 defaults to 1. A blank in Patuxent River line #6, box 10 defaults to 1.

33. Depth (M) (line #6, columns 13-15)
Patuxent River Survey Depth (M) (line #6, columns 11-14)

Enter the depth at which the suite of parameters is measured (in meters).

34. Water Temperature degrees C (line #6, columns 17-20)

The water temperature is recorded in degrees Celsius. The value is recorded in columns 18-20; column #17 is to indicate a minus (-) value. Leave this column blank if temperature is greater than or equal to zero; write in a minus (-) sign if it is below zero.

Patuxent River Survey Water Temperature (line #6, columns 15-18).

On the Patuxent River Survey the temperature value is recorded in columns 16-18; column #15 is used to indicate a minus (-) value. Leave this column blank if temperature is greater than or equal to zero; write in a minus (-) sign if it is below zero.

35. Field pH (line #6, columns 22-25)
Patuxent River Survey Field pH (line #6, columns 19-22)

Enter values for field pH in these columns (round pH to the nearest tenth).

36. Value Corrected (line #6, column 27)
Patuxent River Survey Value Corrected (line #6, column 23)

Use one of the three codes for DO correction in Appendix XI, (usually "C").

37. DO (mg/l) (line #6, columns 28-32)

Enter the DO value in columns 29-32. Column #28 is used to indicate greater than (G) or less than (L) values. A less than (L) in column #28 indicates that the value for DO in columns 29-32 is less than the detection limit for the DO probe. The code "A" may be used in the column designated for G/L when an adjustment has been made for drift found in the post calibration of the meter. The code "E" may be used in the column designated for G/L when the value in columns 29-32 is considered an "estimate" rather than a value that falls within the stated error range. Estimated values may reflect variability at that water depth (i.e., in the mixing zone) or they may reflect an estimate that

appears reasonable to the analyst but they have some reservations; see the comments section for notes explaining the "E" value.

Enter Patuxent River Survey DO value in columns 25-28. Column #24 is used to indicate greater than (G) or less than (L) values. A less than (L) in column #24 indicates that the value for DO in columns 25-28 is less than the detection limit for the DO probe. The code "A" may be used in the column designated for G/L when an adjustment has been made for drift found in the post calibration of the meter. The code "E" may be used in the column designated for G/L when the value in columns 25-28 is considered an "estimate" rather than a value that falls within the stated error range. Estimated values may reflect variability at that water depth (i.e., in the mixing zone) or they may reflect an estimate that appears reasonable to the analyst but they have some reservations; see the comments section for notes explaining the "E" value.

38. Specific Conductance (microSiemens/cm) (line #6, columns 34-39)
Patuxent River Survey Specific Conductance (microSiemens/cm) (line #6, columns 29-34)

Enter the values for specific conductance in columns 35-39. Use column #34 to indicate greater than (G) or less than (L) values. The code "A" may be used in the column designated for G/L when an adjustment has been made for drift in post-calibrating the meter. The code "E" may be used in the column designated for G/L when the analyst considers the value in columns 35-39 to be credible, but outside normal measurement variability.

Enter Patuxent River Survey values for specific conductance in columns 30-34. Use column #29 to indicate greater than (G) or less than (L) values. The code "A" may be used in the column designated for G/L when an adjustment has been made for drift in post-calibrating the meter. The code "E" may be used in the column designated for G/L when the analyst considers the value in columns 30-34 to be credible, but outside normal measurement variability.

NOTE: Hydrolab reports microSiemens/cm.

39. Salinity (ppt) (line #6, columns 40-43) salinity values are rounded to the nearest tenth.
Patuxent River Survey Salinity (ppt) (line #6, columns 35-38)

Enter a value for salinity in columns 40-43.
Enter a value for Patuxent River Survey salinity in columns 35-38.

40. Lab Login Section (line # 6, columns 49-63)
(See 40B below: Patuxent River Survey Layer Code and LiCor Section (line # 6, columns 39-49))

This section is used to record the number of replicate water samples which were collected, the depth at which the samples were collected, the layer from which the samples were collected, and the bottle numbers that the samples were assigned. (Note the designation AP and BP indicate above and below pycnocline only if a pycnocline actually was present. If no pycnocline they indicate below surface and above bottom at 1/3, 2/3 depths.)

A. Replicate (line #6, column 49)

If more than one sample is collected for analysis at an identical depth, indicate this by entering a 1, 2, 3, etc. to differentiate the replicates. Leaving this column blank results in a default to 1.

B. Sample Depth (M) (line #6, columns 50-52)

Record the depth in meters at which the samples were collected. Meter readings are required for this depth.

C. Layer Code (line #6, columns 53-54)

Indicate at which layer the samples were collected. The layer codes are listed in Appendix XI. Enter layer code (S=surface, B=bottom, AP=above pycnocline, BP=below pycnocline, M=mid water column). Left justify single-character codes (i.e., codes with only one letter).

D. Bottle Numbers (line #6, columns 55-63)

Enter the bottle numbers assigned to the samples. Up to nine alphanumeric characters can be used. If less than nine characters are used, left justify. These bottle numbers are the same as those indicated on lab sheets.

40B. Patuxent River Survey Layer Code and LiCor Section (line # 6, columns 39-49)

This section is used to record the layer from which the bottle samples were collected and Deck and Underwater LICor readings.

A. Layer Code (line #6, columns 39 and 40)

Indicate at which layer the samples were collected. The layer codes are listed in Appendix XI. Enter layer code (S=surface, B=bottom, AP=above pycnocline, BP=below pycnocline). Left justify single-character codes (i.e., codes with only one letter).

B. LICor Deck (micromols/m²) (line #6, columns 41-44)

Record the LICor deck value in micromols/m² at depths where readings were taken.

C. LICor Underwater (micromols/m²) (line #6, columns 41-44)

Record the LICor underwater value in micromols/m² at depths where readings were taken.

NOTE: Bottle Numbers on Patuxent River Surveys are entered in an unnumbered column to the left of Patuxent River Survey Replicate Number (line #6, column 10).

41. Pycnocline Threshold Calculations

This section is used as a worksheet to calculate the pycnocline. The following symbols are used in the formula.

Δ = Delta (used to indicate change)

—

\bar{X} = Mean

$\bar{X} \Delta M$ = indicates mean change (Delta) per meter

42. Date entered (entered by keypunch at bottom left of sheet)

Date returned from keypunching (entered by keypunch at bottom of sheet).

43. Page ____ of ____ (bottom right of sheet)

If only one sheet is generated at a station, leave this blank; the default value is 'page 1 of 1.' When two sheets are generated at one station, enter in this area 'page 1 of 2' for the first sheet generated, and 'page 2 of 2' for the second sheet generated. The second sheet generated at a sampling location is Field Sheet B, discussed next.

Field Sheet B:

Use Field Sheet B when two field sheets are generated at one sampling location.

1. Sequence Number

Use the same convention (described above) for sequence number for this field sheet. The second sheet generated at one location must have the identical sequence number as the first sheet. The two sheets should not be stapled together.

2. Top Half of Form

The top of this form only has lines for Sampling Station Number, Date, Start Time, and End Time (the boxes have been replaced with lines). Enter this information to alleviate the problem of mismatched or unidentifiable sheets.

3. Bottom Half of Form

The bottom half of this form is the same as the field sheet previously discussed. There is no need to enter information on the second sheet for the Lab Login or pycnocline calculation.

Lab Sheet (also called filtering volume sheet; for nutrient, suspended solids and chlorophyll analyses)

When nutrient, suspended solids and chlorophyll samples are collected, a lab sheet is generated, and serves as a Sample Transfer Sheet. The lab sheet lists multiple stations that contain information for several samples on one sheet. Information on the sheet includes the sample number, layer, depth, time, salinity, and volume sampled for each set of parameters (e.g., TSS/PP, PC/PN, CHLA). This sheet is filled out by field personnel and must accompany the samples to CBL. CBL produces electronic files which are for uploaded into MD DNR Water Quality Data Management system.

1. Cruise Identification Number (Mainstem stations only)

Enter the cruise identification number in the space provided (year and cruise number, e.g., 97018 for 1997, Cruise Number 18).

2. Date

Enter the date in the space provided. It does not need to be in any specific format.

3. Scientist Signoff

The scientist must check the sheet for completeness and accuracy, and then initial in the signoff space.

4. Station, Sample Number, Layer

Enter the station, sample number, and layer code (S=surface, B=bottom, AP=above pycnocline, BP=below pycnocline, M=mid water column), if not preprinted.

5. Sampling Time (column 5)

Enter the sampling time in military time in column 5.

6. Salinity (column 6)

Enter the salinity in parts per thousand (ppt) in column 6.

7. Vol. (ml) (final 3 or 4 columns)

In the final 3 or 4 columns, enter the volume sampled for each set of sample parameters (e.g., TSS/PP, PC/PN, VSS, CHLA) in milliliters.

C B 5 . 3 Sampling Station Number
0 4 0 2 0 7 Start Date Year Month Day
1 0 5 5 Start time
1 1 1 5 End Time
0 4 Number of Samples
7 9 Submitter code
M B Category Code
0 1 Study Code
0 1 Total Depth M
0 1 Sensor Code
0 1 DO Method
9 7 Air Temp °C
4 0 Air Temp °C
9 7 Probe Number
9 7 Equip. Set Unit #
0 7 Tide State Yesterday
1 0 Weather code Today
0 0 0 Cloud Cover (%)
0 7 Wind Direction
1 0 Wind Velocity (Knots) Max
0 7 Wind Velocity (Knots) Min
0 4 Secchi (M)
0 0 Basis
0 0 Flow Value
0 0 Exp. G/L
0 0 Scientist Sign Off
0 0 Comments

Rep No.	Depth M	Water Temp. °C	Field pH	DO mg/l	Conductivity Micromhos/cm	Salinity ppt	Sample Depth M	Layer Code	LAB LOGIN Bottle Number	Weather Codes
1	05	57	820C	1190	21700	1300	01	05S	#1	10 = none 11 = drizzle 12 = rain 13 = rain, heavy 14 = squally 15 = frozen precipitation
	10	57	820C	1180	21700	1300	01	06B	#2	Wind Velocity 1-3 = slight ripple 4-6 = small waves, not breaking 7-10 = scattered whitecaps 11-16 = numerous whitecaps 17-21 = moderate waves, many whitecaps 22-27 = large waves, many whitecaps 28-33 = sea heaps get of the water! NOW
	20	57	820C	1190	21700	1300	01	09AP	#3	
	30	57	820C	1180	21700	1300	01	190BP	#4	
	50	56	830C	1200	21700	1300				
	70	56	820C	1200	21800	1300				
	90	56	820C	1170	21800	1300				
	100	56	820C	1150	21800	1310				
	110	58	810C	1070	24000	1410				

Wave Height: 0.40m = 1-2 ft, 0.00m = flat calm, 0.09m = slight ripple, 0.20m = ripple - 1 ft, 1.50m = 4-6 ft
 Pycnocline Threshold Calculation: $\Delta \text{cond} / (\text{depth of bottom cond reading} - 0.5) \times \Delta M$
 $31700 - 31600 = 10000$
 $10000 / (25.5 - 25.0) = 20000$
 $X \Delta / M \times 2 = \text{Threshold value}$
 $20000 / 2 = 10000$

Field Sheet A example

Sequence Number
 060201
 3 (punch in 3-9 all cards) 9



Maryland Department of Natural Resources
 Field Sheet

Project Name: Main Bay:Smith Point
 Submitter: AFO-Fabian

Sample Station Number: CBS.3 DATE: 2-7-06 Start Time: 1055 End Time: 1115

Rep No.	Depth M	Water Temp. °C	Field pH	D.O. mg/l	Conductivity Microhos/cm	Salinity ppt	Sample Depth M	Layer Code	LAB LOGIN Bottle Number
11	1.20	5.9	8.00	9.60	29.90	18.50			
	1.30	5.9	7.90	9.60	30.00	18.60			
	1.40	5.9	8.00	9.60	30.10	18.60			
	1.50	5.9	7.90	9.50	30.20	18.70			
	1.60	5.9	7.90	9.50	30.30	18.70			
	1.70	5.9	7.90	9.50	30.50	18.90			
	1.80	6.0	7.90	9.50	31.30	19.40			
	1.90	6.0	8.00	9.50	31.40	19.50			
	2.10	6.1	8.00	9.60	31.60	19.70			
	2.30	6.1	8.00	9.50	31.70	19.70			
	2.50	6.1	8.00	9.60	31.70	19.70			
	2.60	6.1	8.00	9.60	31.70	19.70			

Field Sheet B example

Sequence Number
 3 (punch in 3-9 all cards) 9

Project Name: PXT: Cedar Point
 (KCF9575)

Submitter: MANTA Field Office-McKay
 Patuxent River

Sampling Station Number
 Year Month Day
 20 05 10
 Tide State
 10
 Air Temp °C
 11
 Equip. Set
 9
 LCoor
 1
 Method
 1

Start Date
 Year Month Day
 20 05 10
 Weather Yesterday
 20 05 10
 Weather Today
 20 05 10
 Wave Height (ft)
 20 05 10
 LCoor Method
 20 05 10
 Method
 20 05 10

End Date
 Year Month Day
 20 05 10
 Wind Direction
 20 05 10
 Wind Velocity (knots)
 20 05 10
 Max
 20 05 10
 Sign Off
 20 05 10

Number Samples
 04
 Submitter Code
 60
 Data Category Code
 IN
 Total Depth (M)
 02
 Study Code
 02
 Scientist
 0

Flow Value
 0
 Basis
 0
 G/L
 0
 Secchi (ft)
 0
 Scientist
 0

Start Comments Here:
 0

Weather Codes
 10 = none
 11 = drizzle
 12 = rain
 13 = rain, heavy
 14 = steady
 15 = heavy precipitation

Wind Velocity
 1-3 slight ripple
 4-6 small waves, not breaking
 7-10 scattered whitecaps
 11-16 numerous whitecaps
 17-21 moderate waves, many whitecaps
 22-27 large waves, many whitecaps
 28-33 sea heaps get off the water! NOW

Wave Height
 0.40 m = 1-2 ft
 0.09 m = slight ripple
 0.30 m = ripple-1 ft
 1.50 m = 4-6 ft

DO Method
 L-HydroLab LOO
 Re-YSI ROK

Rep No.	Depth M	Water Temp. °C	Field pH	D.O. %	Dissolved Oxygen mg/L	G/L	Specific Cond. µmhos/cm	Salinity ppt	Layer Code	LCoor Deck	Weather Codes
204	0 1 0										
	0 2 5										
	0 5 0		0 C				0 0	0 S			
	0 7 5										
	1 0 0		0 C				0 0	0			
	1 2 5										
	1 5 0										
	1 7 5		0 C				0 0	0			
	2 0 0										
	2 2 5										
	2 5 0										
	2 7 5										

Patuxent River Field Sheet example

Bay Tributary
Filtering
Volume Sheet
example

DEPARTMENT OF NATURAL RESOURCES
Monitoring and Non-Tidal Assessment
Bay Tributary Filtering Volume Summary
CBL

RUN NAME BT4

DATE _____

FIELD SIGNOFF _____

STATION	SAMPLE TIME (mlty)	FILTER TIME (mlty)	SAMPLE NUMBER	LAYER	DEPTH (M)	SALINITY (ppt)	TSS/PP (ml)	PC/PN (ml)	CHLA (ml)
ET 4.2			21	S	0.5				
			22	AP					
			23	BP					
			24	B					
EE 1.1			25	S	0.5				
			26	AP					
			27	BP					
			28	B					
XGG8251			145	S	0.3				
			R	DUP					

APPENDIX III

MARYLAND DEPARTMENT OF NATURAL RESOURCES CHESAPEAKE BAY WATER QUALITY MONITORING PROGRAM

CROSS REFERENCE SHEET DOCUMENTATION AND PROCEDURES

The following documentation outlines the conventions for filling out the Cross Reference Sheet.

(Note: Although the sheet has a subheading "Progress Report" or "Progress Report / Cross Reference Sheet", it is generally known as the Cross Reference Sheet and should not be confused with the "Cruise Reports/Quarterly Progress Report" described in Appendix IV.)

The Cross Reference Sheet is sent along with Field Sheets from the Field Office to the DNR Tawes Building, so that the DNR data management staff knows what data to expect in the form of field sheets and lab data.

The Cross Reference Sheet includes the name of the program, the sampling month and year, the name of the Field Office representative who originated the sheet. Columns with headings: Station, Day, Depth (m), Sequence #, Sample # list the samples and replicates that were collected. Columns with the headings: Nutrients (CBL), Chloro (CBL), Plankton (Wolny) are used to track whether analytical results have been received by DNR data management. The Comments column is used to enter information explaining missing samples, stations, field abnormalities, or potential data problems.

The structure of the Mainstem and Bay Tributaries cross reference sheets are the same.

Examples of Mainstem and Patuxent River cross reference sheets follow: (labeled "Progress Report/Cross Reference Sheet") follow.

Maryland Department of Natural Resources
RAS/MANTA

Chesapeake Bay **Mainstem**
Progress Report / Cross Reference Sheet

Month/ Year: April /2017

Submitted by: Laura Fabian

Station	Day	Depth (M)	Sequence #	Sample #	Nutrients (CBL)	Chloro. (CBL)	Plankton (Wolny)			Comments	
							Live composites	Fixed/Lugols composites	picoplankton		
CB5.3 Smith Point	11	26.0	1700401	1			N/S			Run postponed 1 day due to ill boat captain and wavy water	
		17.0		2			N/S				
		6.0		3			N/S				
		0.5		4			N/S				
LE2.3 Point Lookout	11	19.0	1700402	5			N/S				
		13.0		6			N/S				
		7.0		7			N/S				
		0.5		8			N/S				
CB5.2 Point No Point	11	30.0	1700403	9			Bottom sample discontinued Nov 2016				
		19.0		10							
		3.0		11			AP and above composite year round	AP and above composite year round			
		0.5/1		12							
		0.5/2		13							
CB5.1 Cedar Point	11	34.0	1700404	14			N/S				
		23.0		15			N/S				
		9.0		16			N/S				
		0.5		17			N/S				

Maryland Department of Natural Resources
MANTA
Chesapeake Bay Water Quality Monitoring
Progress Report – Patuxent River

Month/ Year: January 2015

Submitted by: Debbie McKay

Station	Day	Sample Depth	Sequence Number	Chloro (CBL)	Lab (CBL)	Plankton	Comments
CB5.1W (Cedar Pt.)	06	0.5	1501P01			n/s	No Licor. Boat and Land stations sampled on different days due to a snowstorm.
		3.0				n/s	
		6.0				n/s	
		8.0				n/s	
LE1.4 (Drum Pt.)	06	0.5	1501P02			n/s	Boat and Land stations sampled on different days due to a snowstorm.
		3.0				n/s	
		9.0				n/s	
		16.0				n/s	
LE1.3 (Above Pt. Patience)	06	0.5	1501P03			n/s	Boat and Land stations sampled on different days due to a snowstorm.
		3.0				n/s	
		12.0				n/s	
		22.0				n/s	
LE1.2 (St. Leonard)	06	0.5	1501P04			n/s	Boat and Land stations sampled on different days due to a snowstorm.
		3.0/ 1				n/s	
		12.0				n/s	
		15.0				n/s	
		3.0/ 2				n/s	
LE1.1 (Jack Bay)	06	0.5	1501P05		+VSS		Boat and Land stations sampled on different days due to a snowstorm. Licor data incomplete.
		3.0				n/s	
		9.0				n/s	
		11.0				n/s	

APPENDIX IV

MARYLAND DEPARTMENT OF THE NATURAL RESOURCES CHESAPEAKE BAY WATER QUALITY MONITORING PROGRAM

CRUISE REPORTS/QUARTERLY PROGRESS REPORT DOCUMENTATION AND PROCEDURES

The Cruise Report is filled out by Field Office personnel for each cruise and provided to the Quality Assurance Officer at DNR. Every three months, the Quality Assurance Officer combines and summarizes the Cruise Reports, creating a Quarterly Progress Report to submit to the Chesapeake Bay Program Office.

The Cruise Report includes the cruise identification number, name of the water quality monitoring program, scheduled sampling date, name of the Field Office representative who submits the sheet, additional sampling activities, station names, sampling dates and times, filtration completion times, station departure time, the presence or absence of hydrogen sulfide odor and results of any Hach tests conducted, the research vessel name, the names of the captain, crew, and scientific party, the departure-from-dock time and location, the return-to-dock time and location, weather conditions, air temperature, barometric pressure, estimated wind speed and direction, equipment conditions, morning dissolved oxygen check, sample status and additional comments.

Information filled out by Field Personnel:

Page 1

1. Cruise I.D. (top left of sheet)

Enter the cruise identification number in the space provided at top left of sheet.

2. Page ____ of ____ (top right of page)

When more than one sheet is generated and sent with samples, enter this information in the area provided, 'Page ____ of ____'. If only one sheet is generated, indicate this by entering page 1 of 1.

3. Day # (top right of page, under page number)

Provide the day number of the cruise (i.e., Day #1, Day #2, or Day #3)

4. Study Location (top of sheet)

If not preprinted, enter the name of the study location (e.g., Mainstem Cruise Report) at the

top center of the sheet.

5. Scheduled Sampling Date

Enter the scheduled sampling date in the space provided.

6. Submitted by

Enter the name of the field scientist who originates the sheet.

7. Station Sampled (1st column of sheet)

The station sampled should be preprinted in the first column of the sheet. If not preprinted, enter the station name. (For example, if the samples were collected from station CB5.3, the station sampled would be "CB5.3").

8. Date

Enter the actual date sampled in the space provided.

9. Time

Enter the time the samples are taken.

10. FF (finished filtering)

Enter the time that filtering is finished.

11. LS (left station)

Enter the time of leaving the station.

12. H₂S odor

For both below pycnocline (BP) and bottom (B) layer samples:

- If H₂S odor is present (rotten egg smell), enter "+" and perform a Hach test for hydrogen sulfide. Record the Hach reading.
- If no H₂S odor is present, enter "-".

13. Cruise I.D. (top left of sheet)

Provide the cruise identification number in the space provided at top left of sheet.

Cruise ID numbers consist of last 2 digits of year, 0, and cruise # of year. For example, the cruise ID for the third trip of 2008 would be 08003.

14. Date

Enter the actual sampling date in the space provided.

15. R/V Utilized

Enter the name of the research vessel in the space provided.

16. Captain, Crew and Scientific Party

Enter the names of the Captain, Mate, scientists and occasional collaborators or observers on board. Identify the agency/company that the scientists and observers represent (e.g. DNR, CBL, Baltimore Sun).

17. Departure Time and Location

Enter the departure time and location.

18. Return time and location

Enter the return time and location.

19. Weather conditions

- Enter the air temperature in degrees Celsius for the morning (AM) and afternoon (PM).
- Enter the barometric pressure in inches of mercury for the morning (AM) and afternoon (PM).
- Enter the estimated wind speed in knots and the direction from which the wind is blowing for the morning (AM) and afternoon (PM).

20. Equipment conditions

Enter the refrigerator (FRIDGE) temperature in degrees Celsius. Jan–Jun only (no samples Jul-Dec).

Enter the freezer temperature in degrees Celsius.

21. Morning Dissolved Oxygen (DO) Check

Enter the meter used, meter reading, and whether or not it changed.
Meter readings are logged in Cruise Report when a sonde is changed during a survey.

22. Sample Status

Enter the status of the sample in cases when unusual events might affect a sample. For example, a refrigerator/freezer failure, or samples transported at odd times.

23. Additional Comments

Enter additional comments as needed.

Pages 3 and 5 are the same as Page 1 (for additional stations).

Pages 4 and 6 are the same as Page 2 (for additional stations).

See below for examples of Mainstem and Patuxent Cruise Reports



CRUISE I.D. 14007

MARYLAND DEPARTMENT OF NATURAL RESOURCES

WATER QUALITY MONITORING DIVISION

MAINSTEM CRUISE REPORT

Scheduled Sampling Date: July 7, 2014 Submitted by: _____

Additional Sampling Activities: _____

TABLE OF STATIONS SAMPLED

STATION #	DATE	TIME	COMMENTS*
LE 2.3 Point Lookout	_____	_____	FF- LS- H2S odor BP () B ()
CB 5.3 Smith Point	_____	_____	FF- LS- H2S odor BP () B ()
CB 5.2 Point No Point	_____	_____	FF- LS- H2S odor BP () B ()
CB 5.1 Cedar Point	_____	_____	FF- LS- H2S odor BP () B ()
CB 4.4 Cove Point	_____	_____	FF- LS- H2S odor BP () B ()

* LS-LEFT STATION
 FF-FINISHED FILTERING
 (-) ODOR ABSENT
 (+) ODOR PRESENT (IF + THEN DO HACH KIT)

CRUISE I.D. _____

DATE _____

R/V UTILIZED:

PERSONNEL:

CPT:

DNR

Meter:

CREW:

TSS/PP:

Chla/PC/PN:

LOCATION & TIMES

Hose:

DEPARTED DOCK:

ARRIVED @ DOCK:

WEATHER CONDITIONS:

AM PM

general description:
eg. snotty, nice

Air Temp. _____°C _____°C

Barometer _____

Wind/Speed _____ Kts _____ kts
& Direction

EQUIPMENT CONDITIONS:

AM PM

Fridge _____°C _____°C

freezer temp. _____°C _____°C

MORNING D.O. CHECK:

meter # _____ changed: yes no

meter # _____ changed: yes no

SAMPLE STATUS:

ADDITIONAL COMMENTS:

MARYLAND DEPARTMENT OF NATURAL RESOURCES
 WATER QUALITY MONITORING DIVISION
 PATUXENT CRUISE REPORT

Scheduled Sampling Date: 1/7/13 Submitted by: Debbie McKay
 Additional Sampling Activities: phyto plankton

TABLE OF STATIONS SAMPLED			
STATION	DATE	TIME	COMMENTS
CB5.1W	1/7/13	0841	
LE1.4	1/7/13	0905	
LE1.3	1/7/13	0933	
LE1.2	1/7/13	1000	
LE1.1	1/7/13	1031	
RET1.1	1/7/13	1104	
TF1.7	1/7/13	1137	
TF1.6	1/7/13	1208	
TF1.5	1/7/13	1236	

Sent to Renee Karrh
 1/10/13

R/V UTILIZED KEPHIN

PERSONNEL:
CPT: R. Younger ~~MST~~
CREW: K. Lindenman

DNR: Debbie McKay
Laura Fabian
Lauren Cunningham
Maureen Anderson
Ben Cole

LOCATION & TIMES

DEPARTED DOCK:

3815 Calvert MARINA

FUEL DOCK:

ARRIVAL: _____ DEPARTURE: _____

ARRIVED AT DOCK:

1455

WEATHER CONDITIONS:

	<u>AM</u>	<u>PM</u>	<u>General description (e.g. nice)</u>
Air Temp.	<u>16</u> °C	<u>10</u> °C	
Barometer	<u>30.44</u>	<u>30.52</u>	
Wind Speed & Direction	<u>NW 4-6</u> kts	<u>NW 4-6</u> kts	

SAMPLE STATUS: _____

ADDITIONAL
COMMENTS: _____

APPENDIX V

MARYLAND DEPARTMENT OF NATURAL RESOURCES CHESAPEAKE BAY WATER QUALITY MONITORING PROGRAM

FIELD INSTRUMENT QUALITY ASSURANCE/QUALITY CONTROL

I. MULTIPARAMETER WATER QUALITY INSTRUMENTS

These procedures refer to Hydrolab Series 5 and Yellow Springs Instrument (YSI) Series 6 instruments. Detailed calibration procedures are performed as described in their respective operating manuals.

NOTE:

In March 2015 all remaining Series 4a instrument equipped with Standard Clark Polarographic Dissolved Oxygen Sensors were replaced with Series 5 instruments equipped with optical dissolved oxygen sensors (Luminescent Dissolved Oxygen Sensor - LDO). Calibration logs for each instrument will list specific replacement dates. Sensors for temperature, specific conductance, pH and depth are identical for Series 4a and 5 instruments.

Beginning in February 2009, YSI Series 6 instruments were added to the field instrument inventory. YSI instruments are equipped with optical dissolved oxygen sensors (Reliable Oxygen Sensor - ROX). YSI temperature, specific conductance, pH and depth sensors are different than their respective Hydrolab sensors, but perform similarly.

Both the Hydrolab and YSI optical dissolved oxygen sensors use similar luminescent technology to measure dissolved oxygen.

Mainstem and Patuxent River cruises will exclusively use YSI instead of Hydrolab instruments. All other sampling activities will use Hydrolab or YSI instruments.

A. Calibration

1. Hydrolab Series 5 Instruments

- a. Set up a calibration log book for each instrument with make, model, serial numbers and first-in-service date. Assign a letter for DNR use as required.
- b. Calibrate instruments on Friday for use the next week. If possible, calibrate instrument within 24 hours of first field deployment. After one to four days of field deployment, post-calibrate instruments after last use to determine if calibration of any parameter drifted (see App V, Section I.C.1.c and d for procedure). If possible, post-calibrate instrument within 24 hours after last field deployment.
- c. Calibrate specific conductance sensor with standards generated by the field office from dry KCl and deionized water with specific conductance equal to 0 $\mu\text{S}/\text{cm}$. Standards are 147, 292, 718, 1413, 2767, 6668, 12900, 24820 and 58640 microSiemens/cm ($\mu\text{S}/\text{cm}$) (microSiemens/cm is equivalent to micromhos/cm at 25°C). Respective concentrations are 0.001, 0.002, 0.005, 0.01, 0.02, 0.05, 0.1, 0.2 and 0.5 molar KCl. Calibrate specific conductance sensors of Series 5 instruments following a two point linear protocol. Calibrate the zero point with the sensor dry and the slope with one of the above standards.
- d. Calibrate pH sensor with premixed standards of pH 4.00, pH 7.00 and pH 10.00 purchased from Fisher Scientific. Standards are color coded (red for pH 4.00, yellow for pH 7.00 and blue for pH 10.00) and certified as accurate at 25°C (pH 4.00 \pm 0.01, pH 7.00 \pm 0.01, pH 10.00 \pm 0.02) and used before their labeled expiration dates. Calibrate pH sensor with these standards using a two point linear protocol. First, calibrate the zero point with pH 7.00 standard buffer. Then, calibrate slope with either pH 4.00 or 10.00 standard buffer. The slope buffer is selected so that pH measurements anticipated during field deployment are between the zero point and slope buffer values. The pH value of each buffer is adjusted for instrument temperature before calibration. A pH calibration value vs. temperature table (pH Calibration Table) is supplied by the buffer manufacturer for each standard buffer. This value is the pH calibration point.
- e. Calibrate the optical dissolved oxygen sensor (LDO) using a 1 point percent saturation protocol in the common standard of air saturated water. The volume of water must have a specific conductance less than 100 $\mu\text{S}/\text{cm}$. Determine the oxygen saturation calibration point in air-saturated water from theoretical DO saturation tables using the temperature from the instrument and local barometric pressure from a standard Fortner Mercury Barometer. Instruments used for Mainstem Cruises receive a morning-of-use DO check (App V, Section I.B.2).

A specific notation on the field data sheet shows that Hydrolab instruments are equipped with LDO sensors.

- f. Temperature sensor is calibrated by the manufacturer and cannot be adjusted by the user.
- g. Calibrate depth sensor by submerging it to a known depth at the field sampling station.
- h. Record all calibration and post-calibration information (e.g. barometric pressure, calibration values and instrument readings), maintenance procedures and repairs in the instrument specific calibration log book. An example of this log is included.
- i. During calibration, post-calibration and field deployment, record in the calibration log book any unusual circumstances that may affect instrument readings.

2. YSI Series 6 Instruments

- a. Set up a calibration log book for each instrument with make, model, serial numbers and first-in-service date. Assign a letter for DNR use as required.
- b. Calibrate instruments on Friday for use the next week. If possible, calibrate instrument within 24 hours of first field deployment. After one to four days of field deployment, post-calibrate instruments after last use to determine if calibration of any parameter drifted (see App V, Section I.C.1.c and d for procedure). If possible, post-calibrate instrument within 24 hours after last field deployment.
- c. Calibrate specific conductance sensor with standards generated by the field office from dry KCl and deionized water with specific conductance equal to 0 $\mu\text{S}/\text{cm}$. Standards are 147, 292, 718, 1413, 2767, 6668, 12900, 24820 and 58640 microSiemens/cm ($\mu\text{S}/\text{cm}$) (microSiemens/cm is equivalent to micromhos/cm at 25°C). Respective concentrations are 0.001, 0.002, 0.005, 0.01, 0.02, 0.05, 0.1, 0.2 and 0.5 molar KCl. Calibrate specific conductance sensor following a two point linear protocol with one of the above standards as the slope standard. The zero point is factory calibrated and cannot be adjusted by the user.
- d. Calibrate pH sensor with premixed standards of pH 4.00, pH 7.00 and pH 10.00 purchased from Fisher Scientific. Standards are color coded (red for pH 4.00, yellow for pH 7.00 and blue for pH 10.00) and certified as accurate at 25°C (pH

4.00 ± 0.01, pH 7.00 ± 0.01, pH 10.00 ± 0.02) when used before their labeled expiration dates. Calibrate pH sensor with these standards using a two point linear protocol. First, calibrate the zero point with pH 7.00 standard buffer. Then, calibrate slope with either pH 4.00 or 10.00 standard buffer. The slope buffer is selected so that pH measurements anticipated during field deployment are between the zero point and slope buffer values. The pH value of each buffer is adjusted for instrument temperature before calibration. A pH calibration value vs. temperature table (pH Calibration Table) is supplied by the buffer manufacturer for each standard buffer. This value is the pH calibration point.

- e. Calibrate the optical dissolved oxygen sensor (ROX) using a 1 point percent saturation protocol in the common standard of air saturated water. The volume of water must have a specific conductance less than 100 µS/cm. Check and calibrate, if necessary, the YSI 650 MDS Display Unit barometer to local barometric pressure in mm Hg as measured from a standard Fortner Mercury Barometer. Determine the oxygen saturation calibration point in air-saturated water from theoretical DO saturation tables using the temperature from the instrument and local barometric pressure from a standard Fortner Mercury Barometer or display unit barometer. Note in the calibration if the display unit barometer was calibrated and reading used to calibrate the dissolved oxygen sensor. A specific notation on the field data sheet shows that YSI instruments are equipped with ROX sensors.
- f. Temperature sensor is calibrated by the manufacturer and cannot be adjusted by the user.
- g. Calibrate depth sensor by submerging to a known depth at the field sampling station.
- h. Record all calibration and post-calibration information (e.g. barometric pressure, calibration values and instrument readings), maintenance procedures and repairs in the instrument specific calibration log book. An example of this log is included.
- i. During calibration, post-calibration and field deployment, record in the calibration log book any unusual circumstances which may affect the instrument readings.

B. Field Deployment and Verification of Instrument Performance

1. Teams carry two calibrated instruments in case one instrument gives suspect measurements or fails. Readings from the instrument in use are compared to those from the second instrument only when the field scientist recording measurements observes readings (a) that are outside reasonably expected values, (b) that are variable or erratic, or (c) if the instrument displays an error message. If these instruments do not agree within QA/QC guidelines and the field scientist reasonably believes that the primary instrument is not working correctly, the second instrument is used. This is noted on the field sheet, cruise report, and instrument calibration log. The instrument supervisor is also informed. The suspect instrument should not be used until its performance is evaluated during post-calibration.
2. Each day of a Mainstem Cruise both instruments receive a dissolved oxygen validation check. Set up the instruments for a dissolved oxygen calibration as appropriate for the type of sensor. Follow procedures for the dissolved oxygen validation check to adjust the calibration only if the reading is greater than ± 0.20 mg/L from the saturation calibration point. If the reading is greater than ± 0.50 mg/L, the instrument is not used for field measurements until evaluated by the instrument supervisor.

C. Maintenance

1. Post Field Deployment Maintenance
 - a. Daily: At the end of each day of use, rinse probes with de-ionized or tap water and install the storage cup filled with sufficient tap water so the pH and reference sensors are not submerged.
 - b. Weekly: At the end of each week, rinse instrument (sonde and cable) and basket carrier with tap water. Wipe display with paper towel made wet with tap or deionized water. Rinse probes with de-ionized or tap water and install the storage cup filled with sufficient tap water so the pH and reference sensors are not submerged.
 - c. Post-calibrate dissolved oxygen, pH and specific conductance for each instrument weekly on Friday after one to four days of field sampling. If possible, post-calibrate instrument within 24 hours after last use. Post-calibrate instrument only after sensors stabilize to room temperature (20-25°C). Post-calibrate instruments using the same standards and procedures as were used during calibration except the calibration settings are not adjusted. For instruments with an optical DO sensor, visually inspect the luminescent material

before post-calibration. If DO sensor is damaged, describe the damage in the calibration log and post-calibrate the sensor as is. Damage to DO sensor is repaired before next calibration and field deployment. If during field deployment, instrument readings of pH and specific conductance fall outside the range of the zero and slope calibration standards, make additional post-calibration readings of appropriate pH and specific conductance standards so that field readings fall within the range from the zero calibration point to the additional post-calibration standard. All post-calibration standards and instrument readings are recorded in the calibration log.

- d. If readings of a parameter during post-calibration are outside quality guidelines, note this in the calibration log and inform the field quality assurance supervisor. The supervisor will determine if the instrument is operating correctly and if associated field data are reliable.

Instrument parameter readings that are outside quality guidelines during post-calibration are flagged on field data sheets with the Analytical Problem Code (APC) value 'F'. The description of APC 'F' is: "Field data instrument post calibration failed but data within theoretical limits, (e.g. post cal failed but data kept)" see Appendix XI.

All field data, including instrument data, are re-evaluated during quality assurance, (see step 3 of DATA MANAGEMENT, VERIFICATION AND DOCUMENTATION). If the analyst/biologist and Quality Assurance Officer determine that the data are not usable, values are flagged with the APC code 'V'. The definition for APC code 'V' is: "Sample results rejected due to quality control criteria", see Appendix XI.

2. Routine Sensor Maintenance and Performance Verification: sensor and overall instrument maintenance is conducted at approximately 12 week intervals.
 - a. Hydrolab Series 5 Instrument
 - (1). Optical Dissolved Oxygen Sensor (LDO): Remove plastic cap on end of sensor. Inspect cap for integrity of luminescent material, optical path for water, area under optical glass for condensation, and integrity of o-ring seals. Water or condensation interferes with the optical path. If plastic cap will be reused, replace o-rings if damaged and reinstall cap on sensor. Replace cap and o-rings if damaged. First, gently wipe plastic cap exterior surface with cotton swab soaked with laboratory soap, then rinse cap with deionized water. Second, gently wipe plastic cap exterior surface with new cotton swab soaked with Simple Green™, then rinse cap with deionized water. Replace the plastic cap once per year because of

luminescent material degradation. Organic solvents, such as, methanol and acetone, should never contact any part of this sensor.

- (2). Specific Conductance Sensor (graphite sensor): First, wipe all surfaces of probe with cotton swab soaked with laboratory soap, then rinse with deionized water. Second, wipe probe with new cotton swab soaked with Simple Green™, then rinse with deionized water. Do not use any organic solvents, such as methanol or acetone, to clean this sensor.
- (3). pH System (paired sensors - *in situ* and reference): *in situ* sensor is bulb type Ag/AgCl₂ glass sensor. Reference sensor is a pellet of silver inside a sleeve capped with a porous Teflon™ junction and filled with electrolyte (4M KCl aqueous solution saturated with AgCl₂). First, wipe *in situ* glass sensor with cotton swab soaked with laboratory soap, then rinse with deionized water. Second, wipe glass sensor with new cotton swab soaked with Simple Green™, then rinse with deionized water. Soak sensor in 0.1 N HCl for no more than 30 minutes, then rinse sensor with deionized water. Do not use any organic solvents, such as methanol or acetone, to clean this sensor. Remove junction sleeve from reference sensor. Inspect junction sleeve and silver pellet for integrity and replace if damaged. Do not clean pellet of silver. Remove and discard o-ring from reference sensor post. Lightly grease with silicone grease new o-ring and install on reference sensor post. Install new junction and associated o-ring on sleeve, fill sleeve with fresh electrolyte, add two KCl pellets in sleeve, and reinstall sleeve on reference sensor.
- (4). Depth Sensor (stainless steel differential strain gauge transducer): Inspect sensor port and remove any obstructions. No further maintenance is required.
- (5). Temperature Sensor (stainless steel thermistor): First, wipe with cotton swab soaked with laboratory soap, then rinse with deionized water. Second, wipe with new cotton swab soaked with Simple Green™, then rinse with deionized water. Do not use any organic solvent, such as methanol or acetone, to clean this sensor.

b. YSI Series 6 Instrument

- (1). Optical Dissolved Oxygen Sensor (ROX): Remove membrane assembly on end of sensor. Inspect membrane for integrity of luminescent material, optical path for water, area under optical glass for condensation, and integrity of assembly o-ring seals. Water or condensation interferes with the optical path. Reinstall luminescent membrane assembly. Replace

membrane assembly if damaged. First, gently wipe membrane exterior surface with cotton swab soaked in laboratory soap, then rinse with deionized water. Second, gently wipe membrane exterior surface with new cotton swab soaked in Simple Green™, then rinse with deionized water. Replace the membrane assembly once per year because of luminescent material degradation. Do not use any organic solvents, such as methanol or acetone, to clean this sensor.

- (2). Specific Conductance Sensor (four nickel electrode array): First, soak small nylon bristle brush in laboratory soap and gently push back and forth multiple times through both channels. Rinse with deionized water. Second, soak small nylon bristle brush in Simple Green™ and gently push back and forth multiple times through both channels. Rinse with deionized water.
- (3). pH System: Model 6561 System is a glass bulb type combination electrode consisting of a proton selective glass bulb reservoir filled with buffer at approximately pH 7 and a Ag/AgCl₂ reference electrode. First, gently wipe glass bulb with cotton swab soaked with laboratory soap, then rinse with deionized water. Second, gently wipe glass bulb with new cotton swab soaked with Simple Green™, then rinse with deionized water. If required, soak glass bulb in 1 M HCl for 30 – 60 minutes, then rinse with deionized water. Do not use any organic solvents, such as methanol or acetone, to clean this sensor.

Note: During 2014 YSI pH sensors in all YSI sondes were switched from Model 6561 to Model 6589 (amplified). The Model 6589 sensor has identical glass bulb type combination electrodes and will perform similarly as the Model 6561 but last longer. The Model 6589 is serviced the same as the Model 6561 sensor.

- (4). Depth Sensor YSI Model 6820 Sonde (differential strain gauge transducer): Insure that access ports are clear of debris. Using a plastic syringe flush deionized water through one port and out the others. Repeat flush through each port.

Depth Sensor YSI Model 6920 Sonde (differential strain gauge transducer): Inspect access tunnel for debris and remove. Clean tunnel by first gently pushing new cotton swab soaked with laboratory soap through tunnel, then rinse tunnel with deionized water. Second, gently push new cotton swab soaked with Simple Green™ through tunnel, then rinse tunnel with deionized water.

- (5). Temperature Sensor YSI Model 6820 Sonde (stainless steel thermistor): First, wipe sensor with cotton swab soaked with laboratory soap, then rinse with deionized water. Second, wipe sensor with new cotton swab soaked with Simple Green™, then rinse with deionized water. Do not use any organic solvents, such as methanol or acetone, to clean this sensor.
- c. Sensor Performance Verification: After routine sensor maintenance, the performance of Hydrolab and YSI instruments are verified as follows before assignment to field surveys. Instruments that do not satisfy these criteria are repaired in house or returned to the manufacturer for repair. Performance verification is documented in the calibration log for each instrument.
- (1). Temperature: Submerge sensor and traceable standard mercury thermometer in freshwater at room temperature (20° - 25°C). Instrument reading must be stable and within 0.20°C of the standard thermometer.
 - (2). Dissolved Oxygen: Calibrate optical sensors in the standard of air saturated water. (See App V, Section I.A.1.e for Hydrolab and App V, Section I.A.2.e for YSI). Sensors must calibrate to this saturation standard value and remain stable within 0.05 mg/L of standard over a two minute interval.
 - (3). pH: Calibrate system using the two point linear protocol (see App V, Section I.A.1.d for Hydrolab and App V, Section I.A.2.d for YSI). Calibrate zero point with pH 7 standard buffer. Calibrate slope with pH 10 standard buffer but do not calibrate. Check response of system to pH 4 standard buffer but do not calibrate. Instrument should read stable pH values within 2 minutes of immersion in standard buffer whether calibrated or not. Instrument readings of pH 10 and 4 standard buffers should be within 0.20 units of standard value as determined from pH Calibration Table.

After calibration, YSI pH 6561 and 6589 sensors must have stable milliVolt (mV) readings in standard buffers within the following ranges:

pH 7 buffer	-30 to +30 mV
pH 10 buffer	-210 to -150 mV
pH 4 buffer	+150 to +210 mV

If mV readings are not within these ranges, pH sensor must be replaced.

(4). Specific Conductance

For Hydrolab Series 5 instruments calibrate in any of three autoranges (0 – 1500 $\mu\text{S}/\text{cm}$, 1500 – 15,000 $\mu\text{S}/\text{cm}$, and 15,000 – 150,000 $\mu\text{S}/\text{cm}$) using a two point linear protocol (see App V, Section I.A.1.c). Select a standard in another autorange and check linearity response. Instrument reading should be within $\pm 5\%$ of standard.

For YSI Series 6 instruments calibrate with a standard from one of the three Hydrolab autoranges above using a two point linear protocol (see App V, Section I.A.2.c). Select a standard in another Hydrolab autorange and check linearity response. Instrument reading should be within $\pm 5\%$ of standard.

(5). Depth: Calibrate zero point in air. Sensor should calibrate and read stable value.

II. **LI-COR® INSTRUMENTATION MAINTENANCE:**

Photosynthetic Active Radiation (PAR) is measured using LI-COR® Bioscientific equipment. Each LI-COR® setup is comprised of an LI-1400 display unit, an LI-190SA ambient light sensor, and an LI-192SA underwater light sensor, an underwater leveling frame, and an underwater cable attached to a calibrated lowering-line.

The following factory-maintenance procedure ensures compliance with the manufacturer's required maintenance schedule. Each winter half of the ambient and underwater sensors are shipped to LI-COR® Bioscientific for re-calibration. The next year, the remaining ambient and underwater sensors are sent to the factory for re-calibration. Upon return from the factory, updated, sensor specific, correction values are entered into the displays before the equipment is deployed.

The LI-1400 display units are battery powered. Twice each year, the four AA batteries in each of the display units are replaced with new AA batteries.

Lowering-lines are evaluated yearly to ensure depth markings are correctly located. Troubleshooting is performed as necessary before sending PAR measurement components to the factory for repair.

A LI-COR equipment tracking maintenance log is used to document which instrumentation components are attached to specific display units. As well as, provide a permanent record of all re-calibrations, battery replacements, lowering-line checks and equipment repairs.

IV. SECCHI DISK

Each year the Secchi disk line is calibrated by comparing its 0.2m marks to a metal meter stick. Each mark is a small piece of colored flat synthetic webbing pulled through the line and sewn for security. Marks are moved if the webbing does not line up with the corresponding line on the meter stick.

V. AUDITS

Annual audits of all field equipment log books, maintenance records and field procedures will be conducted by the field quality assurance officer. This information will be reported to the DNR Quality Assurance Officer. (See Quality Assurance Project Plan, Section 8: Project Organization and Responsibility).

The following pages contain examples of calibration logs for Hydrolab Series 5 and YSI Series 6 instruments.

Note: The example Hydrolab Calibration log form and instructions are in use as of November 1, 2016. Revisions are planned. References to deprecated equipment and procedures will be removed and guidance for temperature thermistors will be added.

VI. INSTRUMENT CALIBRATION LOGS

The following pages are calibration logs and their documentation for Hydrolab Series 5 and YSI Series 6 instruments. These revisions have been used since July 2009.

DATE: MM/DD/YYYY					
TIME: HH:MM (MILITARY TIME)					
LOCATION: OFFICE, HOME, FIELD, MOTEL					
CALIBRATION TYPE: CAL, POST CAL, CHECK, TEST					
PROJECT					
CHECKED BY: INITIALS					

DISSOLVED OXYGEN – CLARK POLAROGRAPHIC CELL (water saturated air – mg/L protocol)

TEMPERATURE: °C					
BAROMETRIC PRESSURE: mm Hg					
CALIBRATION D. O.: mg/L					
D. O. READING: mg/L					
ADJUSTED: CIRCLE ONE	YES NO	YES NO	YES NO	YES NO	YES NO

DISSOLVED OXYGEN – OPTICAL SENSOR (air saturated water – percent saturation protocol)

TEMPERATURE: °C					
BAROMETRIC PRESSURE: mm Hg					
CALIBRATION D. O.: % sat / mg/L					
D. O. READING: % sat / mg/L					
ADJUSTED: CIRCLE ONE	YES NO	YES NO	YES NO	YES NO	YES NO

SPECIFIC CONDUCTANCE (uSiemens/cm)

ZERO POINT: READING / ADJUSTED		YES NO		YES NO		YES NO		YES NO		YES NO
SLOPE	TEMPERATURE: °C									
	STANDARD: uS/cm									
	METER READING: uS/cm									
ADJUSTED: CIRCLE ONE	YES NO	YES NO	YES NO	YES NO	YES NO	YES NO	YES NO	YES NO	YES NO	

pH

pH 7 ZERO POINT	TEMPERATURE: °C					
	CHART pH: pH units					
	METER READING: pH units					
	ADJUSTED: CIRCLE ONE	YES NO	YES NO	YES NO	YES NO	YES NO
pH 4/10 SLOPE	TEMPERATURE: °C					
	CHART pH: pH units					
	METER READING: pH units					
	ADJUSTED: CIRCLE ONE	YES NO	YES NO	YES NO	YES NO	YES NO

BATTERY: BATTERY / VOLTS					
--------------------------	--	--	--	--	--

QA/QC SIGN OFF: INITIALS					
--------------------------	--	--	--	--	--

DATE: MM/DD/YYYY	COMMENTS (INITIALED)

**HYDROLAB INSTRUMENT CALIBRATION LOG DOCUMENTATION
SERIES 4a/5
JULY 2009**

PAGE HEADER INFORMATION – row of information at top of page.

1. METER – record letter identifier, in upper case, for instrument on this log page.
2. PAGE NUMBER – record next page number in sequence; pages numbered sequentially from first use of letter identifier.

LOG ENTRY – one column is one log entry.

HEADER INFORMATION

1. DATE – record date with month and day as two digit fields each and year as four digit field. Separate fields with slash.
2. TIME – record time in military format (hours and minutes as two digit fields each) when beginning work.
3. LOCATION – record place where work performed as one of four choices (office, home, field, or motel); if not one of four choices, be as specific as possible.
4. CALIBRATION TYPE – record type of work performed as one of these choices:
 - CAL – calibration performed before field deployment; calibration adjusted if necessary.
 - POST CAL – post-calibration performed as calibration check after field deployment; no calibration adjustments.
 - CHECK – check calibration of specific parameter(s); calibration adjustments possible.
 - TEST – instrument performance test performed for maintenance or repair reasons.
5. PROJECT – record project(s) on which instrument intended to be used or was used.
6. CHECKED BY – record initials of person(s) performing work; initials are three character field. Separate multiple persons with slash.

DISSOLVED OXYGEN – CLARK POLAROGRAPHIC CELL

1. TEMPERATURE – record temperature in degrees centigrade as displayed on the instrument. Reading used to determine “CALIBRATION D. O.” entry.
2. BAROMETRIC PRESSURE – record temperature corrected local barometric pressure in millimeters of mercury from a Fortin mercury barometer. Reading used to determine “CALIBRATION D. O.” entry.
3. CALIBRATION D. O. – record dissolved oxygen concentration in milligrams per liter from calibration chart or calculation.
4. D. O. READING – record dissolved oxygen concentration in milligrams per liter as displayed on the instrument before making calibration adjustments.
5. ADJUSTED – circle “yes” or “no” if calibration setting was changed or not changed, respectively.

DISSOLVED OXYGEN – OPTICAL SENSOR

1. TEMPERATURE – record temperature in degrees centigrade as displayed on the instrument. Reading used to determine “CALIBRATION D.O.” entry.
2. BAROMETRIC PRESSURE – record temperature corrected local barometric pressure in millimeters of mercury from a Fortin mercury barometer. Reading used to determine “CALIBRATION D.O.” entry.
3. CALIBRATION D.O. – record dissolved oxygen concentration as percent saturation and milligrams per liter from calibration chart or calculation.
4. D. O. READING – record dissolved oxygen concentration as percent saturation and milligrams per liter as displayed on the instrument before making calibration adjustments.
5. ADJUSTED – circle “yes” or “no” if calibration setting was changed or not changed, respectively.

SPECIFIC CONDUCTANCE

- A. ZERO POINT – record “zero” reading from instrument display before making calibration adjustments. Circle “yes” or “no” if calibration setting was changed or not, respectively.

- B. SLOPE
 - 1. TEMPERATURE – record temperature in degrees centigrade as displayed on the instrument.
 - 2. STANDARD – record specific conductance of standard in microSiemens per centimeter as written on the bottle of standard.
 - 3. METER READS – record specific conductance of standard in microSiemens per centimeter as displayed on the instrument before making calibration adjustments.
 - 4. ADJUSTED – circle “yes” or “no” if calibration setting was changed or not changed, respectively.

pH

- A. pH 7 – ZERO POINT
 - 1. TEMPERATURE – record temperature in degrees centigrade as displayed on the instrument.
 - 2. CHART pH – record pH in pH units from calibration chart.
 - 3. METER READS – record pH in pH units as displayed on the instrument before making calibration adjustments.
 - 4. ADJUSTED – circle “yes” or “no” if calibration setting was changed or not changed, respectively.

- B. pH 4/10 BUFFER – SLOPE
 - 1. TEMPERATURE – record temperature in degrees centigrade as displayed on the instrument.
 - 2. CHART pH – record pH in pH units from calibration chart.
 - 3. METER READS – record pH in pH units as displayed on the instrument before making calibration adjustments.
 - 4. ADJUSTED – circle “yes” or “no” if calibration setting was changed or not changed, respectively.

BATTERY

Record letter or number identity of battery connected to instrument (record internal battery as letter or number identity of display). Record voltage reading of this battery as displayed on the instrument. Separate each field with a slash.

QA/QC SIGN OFF

Scientist who verified completeness and accuracy of log entry records his/her initials.

COMMENTS

1. DATE – record date of entry with month and day as two digit fields each and year as four digit field. Separate fields with slash.
2. COMMENTS – comments should be long enough to cover the subject but short enough to be interesting. Initials of person making entry should be at end of comments.

NOTE: to facilitate matching comments with log entry, a circled number should appear both at the top of appropriate log entry column and preceding the date in the comments section. This circled number should be unique and sequential to each log page.

YSI INSTRUMENT CALIBRATION LOG
(July 2009)

YSI SERIES 6 METER _____

PAGE NO. _____

DATE: MM/DD/YYYY					
TIME: HHMM (MILITARY TIME)					
LOCATION: OFFICE, HOME, FIELD, MOTEL					
CALIBRATION TYPE: CAL, POSTCAL, CHECK, TEST					
PROJECT:					
CHECKED BY: INITIALS					

DISSOLVED OXYGEN – OPTICAL SENSOR (air saturated water – percent saturation protocol)

TEMPERATURE: °C					
BAROMETRIC PRESSURE: mm Hg					
CALIBRATION D. O.: % sat / mg/L					
D. O. READING: % sat / mg/L					
ADJUSTED: CIRCLE ONE	YES NO	YES NO	YES NO	YES NO	YES NO

SPECIFIC CONDUCTANCE (µSiemens/cm)

SLOPE	TEMPERATURE: °C				
	STANDARD: µS/cm				
	METER READS: µS/cm				
	ADJUSTED: CIRCLE ONE	YES NO	YES NO	YES NO	YES NO

pH

pH 7 ZERO POINT	TEMPERATURE: °C				
	CHART pH: pH units				
	METER READS: pH units				
	ADJUSTED: CIRCLE ONE	YES NO	YES NO	YES NO	YES NO
pH 4/10 SLOPE	TEMPERATURE: °C				
	CHART pH: pH units				
	METER READS: pH units				
	ADJUSTED: CIRCLE ONE	YES NO	YES NO	YES NO	YES NO

QA/QC SIGN OFF: INITIALS					
--------------------------	--	--	--	--	--



DATE: MM/DD/YYYY	COMMENTS (INITIALED)

**YSI INSTRUMENT CALIBRATION LOG DOCUMENTATION
SERIES 6
JULY 2009**

PAGE HEADER INFORMATION – row of information at top of page.

1. METER – record letter identifier, in upper case, for instrument on this log page.
2. PAGE NUMBER – record next page number in sequence; pages numbered sequentially from first use of letter identifier.

LOG ENTRY – one column is one log entry.

HEADER INFORMATION

1. DATE – record date with month and day as two digit fields each and year as four digit field. Separate fields with slash.
2. TIME – record time in military format (hours and minutes as two digit fields each) when beginning work.
3. LOCATION – record place where work performed as one of four choices (office, home, field, or motel); if not one of four choices, be as specific as possible.
4. CALIBRATION TYPE – record type of work performed as one of these choices:
 - CAL – calibration performed before field deployment; calibration adjusted if necessary.
 - POST CAL – post-calibration performed as calibration check after field deployment; no calibration adjustments.
 - CHECK – check calibration of specific parameter(s); calibration adjustments possible.
 - TEST – instrument performance test performed for maintenance or repair reasons.
5. PROJECT – record project(s) on which instrument intended to be used or was used.
6. CHECKED BY – record initials of person(s) performing work; initials are three character field. Separate multiple persons with slash.

DISSOLVED OXYGEN – OPTICAL SENSOR

1. TEMPERATURE – record temperature in degrees centigrade as displayed on the instrument. Reading used to determine “CALIBRATION D.O.” entry.
2. BAROMETRIC PRESSURE – record temperature corrected local barometric pressure in millimeters of mercury from a Fortin mercury barometer. Reading used to determine “CALIBRATION D.O.” entry.
3. CALIBRATION D.O. – record dissolved oxygen concentration as percent saturation and milligrams per liter from calibration chart or calculation.
4. D. O. READING – record dissolved oxygen concentration as percent saturation and milligrams per liter as displayed on the instrument before making calibration adjustments.
5. ADJUSTED – circle “yes” or “no” if calibration setting was changed or not changed, respectively.

SPECIFIC CONDUCTANCE

A. SLOPE

1. TEMPERATURE – record temperature in degrees centigrade as displayed on the instrument.
2. STANDARD – record specific conductance of standard in microSiemens per centimeter as written on the bottle of standard.
3. METER READS – record specific conductance of standard in microSiemens per centimeter as displayed on the instrument before making calibration adjustments.
4. ADJUSTED – circle “yes” or “no” if calibration setting was changed or not changed, respectively.

pH

A. pH 7 – ZERO POINT

1. TEMPERATURE – record temperature in degrees centigrade as displayed on the instrument.
2. CHART pH – record pH in pH units from calibration chart.
3. METER READS – record pH in pH units as displayed on the instrument before making calibration adjustments.
4. ADJUSTED – circle “yes” or “no” if calibration setting was changed or not changed, respectively.

B. pH 4/10 BUFFER – SLOPE

1. TEMPERATURE – record temperature in degrees centigrade as displayed on the instrument.
2. CHART pH – record pH in pH units from calibration chart.
3. METER READS – record pH in pH units as displayed on the instrument before making calibration adjustments.
4. ADJUSTED – circle “yes” or “no” if calibration setting was changed or not changed, respectively.

QA/QC SIGN OFF

Scientist who verified completeness and accuracy of log entry records his/her initials.

COMMENTS

1. DATE – record date of entry with month and day as two digit fields each and year as four digit field. Separate fields with slash.
2. COMMENTS – comments should be long enough to cover the subject but short enough to be interesting. Initials of person making entry should be at end of comments.

NOTE: to facilitate matching comments with log entry, a circled number should appear both at the top of appropriate log entry column and preceding the date in the comments section. This circled number should be unique and sequential to each log page.

APPENDIX VI

MARYLAND DEPARTMENT OF NATURAL RESOURCES CHESAPEAKE BAY WATER QUALITY MONITORING PROGRAM

FIELD PROCEDURES QUALITY ASSURANCE / QUALITY CONTROL

I. Cleaning procedures (A-D are performed by Chesapeake Biological Lab staff members):

- A. Autoanalyzer (AA) cups and caps: Cups and caps are used only one time and then are discarded.
- B. DOC tubes: Place tubes in 10 % HCl bath for approximately 24 hours; follow by rinsing tubes several times in deionized water.
- C. DOC caps: Place caps in 10 % HCl bath for approximately 24 hours; follow by rinsing tubes several times in deionized water.
- D. TDN/TDP tubes: New tubes are digested using potassium persulfate followed by multiple deionized water rinses. Tubes that are "in-the-cycle" are cleaned by emptying old contents, rinsing the tubes and caps with 3-4 tap water rinses followed by 6 rinses with deionized water.

II. Review of procedures for field and lab sheets in the field

A. "Scientist signoff" duties

The field scientist is responsible for recording values on the field data sheets and on the lab sheets. This includes entering all Hydrolab/YSI *in situ* values, calculating the pycnocline, and ensuring that the field data sheet is complete. This individual is also responsible for transcribing necessary header information onto the lab sheets.

B. "Senior scientist" duties

The individual who enters their initials in the 'senior scientist' boxes is the scientist who is officially designated as being in charge of the cruise.

Mainstem Cruises:

1. The senior scientist, as field quality assurance officer on cruise, should ensure that:
 - a. Thermometers are placed in refrigerator and freezer to monitor daily temperatures (4 °C for refrigerator and -10 to -20 °C for freezer) and record data on cruise report.

(The refrigerator is used January-June, to keep silicate samples cool). If the temperatures are too high; they should be set lower if possible and if not possible, the Captain of the research vessel should be notified.

- b. Check with Captain of the research vessel to ensure that weather and location instruments used onboard the ship (e.g., Raytheon factory calibrated barometer, anemometer, or GPS) are functioning properly and, if not, record it in the Cruise Report.
- c. Check to make sure all equipment necessary to accomplish sampling is on board and functioning before leaving dock.
- d. Document and report back to the field quality assurance officer any deviations from existing protocol or problems that have arisen during the cruise.

III. Dissolved Oxygen Calibrations and Checks

Dissolved Oxygen calibration checks shall be done every morning for Mainstem Monitoring. Typically the instruments used on Mainstem employ optical DO probes and are checked using the common standard of air-saturated water. After correcting for the barometric pressure and temperature, the oxygen content of air saturated water can be checked against standard D.O. tables. In cases where the dissolved oxygen probe is a standard Clark cell, the probe is checked using the water-saturated air protocol.

IV. Spare Instrument

As discussed in Appendix 5 (Field Instrument Quality Assurance/Quality Control), teams carry two calibrated Hydrolab/YSI meters in case of failure. The meter in use is compared to the reserve meter any time (a) the field scientist recording measurements observes values outside the "typically expected range"; (b) the meter generates variable or erratic values; or, (c) the meter in use displays an error message. If the meters do not agree within acceptable limits, the reserve meter is used. This is noted under the additional comments section.

V. Deionized water

The deionized water at the Field Office is generated from tap water using a Thermo Scientific Barnstead DIAMOND TII RO/DI system with a GE SmartWater external pre-filter. The RO/ DI system is linked to a Thermo Scientific Barnstead DIAMOND TII 60L storage reservoir. The system uses a thin film composite reverse osmosis membrane with pretreatment to produce RO water. This water is then put through a two-stage deionization process combined with UV oxidation and a 0.2 micron final filter. The reagent grade water provided by this system exceeds ASTM Type II and NCCLS/CAP Type I standards. All manufacturer recommendations are followed regarding cartridge replacement and system sanitation (Refer

to Thermo Scientific. 2007. Barnstead DIamond TII Type II Water System Operation Manual and Barnstead DIamond TII Type II Storage Reservoir Operation Manual). The GE SmartWater pre-filter was placed in-line to improve the integrity of feed-water going into the Barnstead DIamond System. The pre-filter is changed at least every three (3) months or more frequently during periods of heavy use. A log is kept at the front of the DI System Manual to document all changes and updates made to the system.

VI. Transfer of nutrient samples/sheets to laboratory

All samples are delivered to CBL at the end of the sampling week. The samples are placed in the freezer at the Field Office until delivery. The silicate samples that are collected at a subset of stations are stored in the Field Office refrigerator. The samples are packed with dewatered ice in a cooler. Do not place the silicates directly in the ice as this may cause them to freeze. The volume sheets for each sampling run are placed in a bin marked "CBL" on the side of the Field Office freezer at the end of the field day. The laboratory (volume) sheets must be collected from the bin and accompany all samples to CBL.

UNIVERSITY OF MARYLAND CENTER FOR ENVIRONMENTAL SCIENCE
CHESAPEAKE BIOLOGICAL LABORATORY
NUTRIENT ANALYTICAL SERVICES LABORATORY
146 Williams St., Solomons MD 20688
<http://nasl.cbl.umces.edu/>

**Standard Operating Procedure for
Determination of Dissolved Inorganic Ammonium (NH₄) in Fresh/Estuarine/Coastal
Waters
(References Standard Methods 4500-NH₃ G-1997)**

**Revision 2017-2
Replaces Revision 2015
Effective April 26, 2017**

Revised by: _____ Date: _____

Reviewed by: _____ Date: _____

Laboratory Supervisor: _____ Date: _____

Section 1.7: Changed to references Standard Methods 4500-NH3 G-1997
Section 3.4: Changed analytical range from 0.01-1.68 to 0.001-1.68
Section 3.5: Deleted preparation batch definition
Section 3.12.3: Changed CCV range to be done every 18-23 samples
Entire Document: Replaced deionized water with reagent water
Section 3.26: Added This is also referred to as the Quantitation Limit
Section 3.35: Added Also referred to as CRM
Section 3.42: Added Also referred to as CRM
Section 5.1: Changed should to must, Changed CBL Business Manager to CBL Associate
Director of Administration and Facilities Maintenance
Table 1: Updated and changed to new safety standards
Section 6.1: Added Windows 7 operating system
Section 7.7: Changed stock standard to be made in 500ml instead of 1L
Section 7.8: Removed the word regular
Section 7.10: Deleted information about making Aquakem Cleaning Solution the old way
Section 8.3: Added sample cups
Section 9.2.1: Added iDOC acronym
Section 9.2.4: Changed ambient water to natural water, Added and process through the
entire analytical procedure
Section 9.2.5: Deleted or a new matrix is encountered
Section 9.3.1: Deleted LRB above the lowest standard requires that the source of the
problem must be identified and corrected before proceeding with analysis
Section 9.3.4: Added reagent blanks to control charts, deleted set up an accuracy chart by
using percent recovery since the concentration of the QCS/SRM varies
Section 9.3.5: Added ICV to the CCV information, changed TV to say the expected value
Section 9.3.6: Deleted the section describing reagent blank
Section 9.4: Changed the % symbol to percent Section 9.7: Added Table 2
Section 10.1: Added 6 or 7 calibration points, removed the word regular, updated
ammonium calibrators
Section 9.2: Changed the Pearson r acceptance value to 0.995
Section 11: Added step by step details for using the Aquakem software
Section 11.16: Changed the word usual to recommended
Section 12.2: Added 20ppt and above to the description
Section 13: Deleted Method Performance Section
Section 14.1 (Now section 13): Removed USPEA Method 353.2 reference
Appendix A: Added Appendix A to describe the salinity effects on ammonium analysis

Determination of Dissolved Inorganic Ammonium (NH₄) in Fresh/Estuarine/Coastal Waters

1. SCOPE and APPLICATION

- 1.1 Determination of ammonium is by the Bertholet Reaction in which a blue-colored compound, similar to indophenol, forms when a solution of ammonium salt is added to sodium phenoxide. The method is used to analyze all ranges of salinity.
- 1.2 A Method Detection Limit (MDL) of 0.001 mg NH₄-N/L was determined using the Student's *t* value (3.14) times the standard deviation of seven low level replicates. If more than seven replicates are used to determine the MDL, refer to the Student's *t* test table for the appropriate n-1 value.
- 1.3 The Quantitation Limit for NH₄ was set at 0.010 mg NH₄-N/L.
- 1.4 The method is suitable for NH₄ concentrations 0.001 to 1.68 mg NH₄-N/L.
- 1.5 This procedure should be used by analysts experienced in the theory and application of aqueous inorganic analysis. Three months experience with an analyst, experienced in the analysis of ammonium in aqueous samples, is required.
- 1.6 This method can be used for all programs that require analysis of dissolved ammonium.
- 1.7 This procedure references Standard Methods 4500-NH₃ G-1997.

2. SUMMARY

2.1 Filtered samples are complexed with sodium potassium tartrate and sodium citrate. The complexed sample reacts with alkaline phenol and hypochlorite, catalyzed by sodium nitroprusside, yielding an intense blue color suitable for photometric measurement.

3. DEFINITIONS

- 3.1 Acceptance Criteria – Specified limits placed on characteristics of an item, process, or service defined in a requirement document. (ASQC)
- 3.2 Accuracy – The degree of agreement between an observed value and an accepted reference value. Accuracy includes a combination of random error (precision) and systematic error (bias) components which are due to sampling and analytical operations; a data quality indicator. (QAMS)
- 3.3 Aliquot – A discrete, measured, representative portion of a sample taken for analysis. (EPA QAD Glossary)
- 3.4 Analytical Range – 0.01292 to 1.68 mg NH₄-N/L. The overall analytical range is comprised of two distinct concentration ranges. A

separate calibration is performed for each range. These ranges include 0.01292 to 0.168 mg NH₄-N/L, and 0.168 to 1.68 mg NH₄-N/L. Two sub-ranges are utilized so that samples can be analyzed on the most appropriate scale possible.

- 3.5 Batch – Environmental samples, which are prepared and /or analyzed together with the same process and personnel, using the same lot(s) of reagents. An **analytical batch** is composed of prepared environmental samples (extracts, digestates, concentrates) and/or those samples not requiring preparation, which are analyzed together as a group using the same calibration curve or factor. An analytical batch can include samples originating from various environmental matrices and can exceed 20 samples. (NELAC/EPA)
- 3.6 Blank- A sample that has not been exposed to the analyzed sample stream in order to monitor contamination during sampling, transport, storage or analysis. The blank is subjected to the usual analytical and measurement process to establish a zero baseline or background value and is sometimes used to adjust or correct routine analytical results. (ASQC)
- 3.7 Calibrate- To determine, by measurement or comparison with a standard, the correct value of each scale reading on a device. The levels of the applied calibration standard should bracket the range of planned or expected sample measurements. (NELAC)
- 3.8 Calibration – The set of operations which establish, under specified conditions, the relationship between values indicated by a measuring device. The levels of the applied calibration standard should bracket the range of planned or expected sample measurements. (NELAC)
- 3.9 Calibration Blank – A volume of reagent water fortified with the same matrix as the calibration standards, without analyte added.
- 3.10 Calibration Curve – The graphical relationship between known values, such as concentrations, or a series of calibration standards and their analytical response. (NELAC)
- 3.11 Calibration Method – A defined technical procedure for performing a calibration. (NELAC)
- 3.12 Calibration Standard – A substance or reference material used to calibrate an instrument. (QAMS)
 - 3.12.1 Initial Calibration Standard (STD) – A series of standard solutions used to initially establish instrument calibration responses and develop calibration curves for individual target analytes.
 - 3.12.2 Initial Calibration Verification (ICV) – An individual standard, distinct from the Initial Calibration Standards (STD), analyzed initially, prior to any sample analysis, which verifies acceptability of the calibration curve or previously established calibration curve.

- 3.12.3 Continuing Calibration Verification (CCV) – An individual standard, distinct from the Initial Calibration Standards (STD), analyzed after every 18-23 field sample analyses.
- 3.13 Certified Reference Material (CRM) – A reference material one or more of whose property values are certified by a technically valid procedure, accompanied by or traceable to a certificate or other documentation which is issued by a certifying body. (ISO 17025)
- 3.14 Corrective Action – Action taken to eliminate the causes of an existing nonconformity, defect or other undesirable situation in order to prevent recurrence. (ISO 8402)
- 3.15 Deficiency – An unauthorized deviation from acceptable procedures or practices. (ASQC)
- 3.16 Demonstration of Capability – A procedure to establish the ability of the analyst to generate acceptable accuracy. (NELAC)
- 3.17 Detection Limit – The lowest concentration or amount of the target analyte that can be determined to be different from zero by a single measurement at a stated degree of confidence.
- 3.18 Duplicate Analysis – The analyses of measurements of the variable of interest performed identically on two sub samples (aliquots) of the same sample. The results from duplicate analyses are used to evaluate analytical or measurement precision but not the precision of sampling, preservation or storage internal to the laboratory. (EPA-QAD)
- 3.19 External Standard (ES) – A pure analyte (Ammonium Sulfate ($(\text{NH}_4)_2\text{SO}_4$)) that is measured in an experiment separate from the experiment used to measure the analyte(s) in the sample. The signal observed for a known quantity of the pure external standard is used to calibrate the instrument response for the corresponding analyte(s). The instrument response is used to calculate the concentrations of the analyte(s) in the unknown sample.
- 3.20 Field Duplicates (FD1 and FD2) – Two separate samples collected at the same time and place under identical circumstances and treated exactly the same throughout field and laboratory procedures. Analyses of FD1 and FD2 provide a measure of the precision associated with sample collection, preservation and storage, as well as with laboratory procedures.
- 3.21 Holding time – The maximum time that samples may be held prior to analysis and still be considered valid. (40 CFR Part 136) The time elapsed from the time of sampling to the time of extraction or analysis, as appropriate.
- 3.22 Laboratory Duplicates (LD1 and LD2) – Two aliquots of the same sample taken in the laboratory and analyzed separately with identical procedures. Analyses of LD1 and LD2 indicate precision associated with laboratory procedures, but not with sample collection, preservation, or storage procedures.
- 3.23 Laboratory Reagent Blank (LRB) – A matrix blank (i.e., Reagentwater) that is treated exactly as a sample including exposure to

all glassware, equipment, solvents, and reagents that are used with other samples. The LRB is used to determine if method analytes or other interferences are present in the laboratory environment, the reagents, or the instrument.

- 3.24 Laboratory Control Sample (LCS) – A sample matrix, free from the analytes of interest, spiked with verified known amounts of analytes from a source independent of the calibration standard or a material containing known and verified amounts of analytes. The LCS is generally used to establish intra-laboratory or analyst-specific precision and bias or to assess the performance of all or a portion of the measurement system. (NELAC)
- 3.25 Limit of Detection (LOD) – The lowest concentration level that can be determined by a single analysis and with a defined level of confidence to be statistically different from a blank. (ACS)
- 3.26 Limit of Quantitation (LOQ) – The minimum levels, concentrations, or quantities of a target variable (target analyte) that can be reported with a specified degree of confidence. The LOQ is set at 3 to 10 times the LOD, depending on the degree of confidence desired. This is also referred to as the Quantitation Limit.
- 3.27 Linear Dynamic Range (LDR) – The absolute quantity over which the instrument response to an analyte is linear. This specification is also referred to as the Linear Calibration Range (LCR).
- 3.28 Material Safety Data Sheets (MSDS) – Written information provided by vendors concerning a chemical's toxicity, health hazards, physical properties, fire, and reactivity data including storage, spill, and handling precautions.
- 3.29 May – Denotes permitted action, but not required action. (NELAC)
- 3.30 Method Detection Limit (MDL) – The minimum concentration of an analyte that can be identified, measured, and reported with 99% confidence that the analyte concentration is greater than zero (Standard Methods).
- 3.31 Must – Denotes a requirement that must be met. (Random House College Dictionary)
- 3.32 Photometer – measures the absorbance of the solution in the cell in a multicell cuvette. Light passes from the lamp through the condensing lenses to the interference filter. The plane surface of the first condensing lens is coated with a material which reflects heat and infrared light. The filters are mounted on a filter wheel. There are 15 positions for filters. Each filter corresponds to a wavelength of interest. The 630 nm filter is specified by the test definition for ammonium. After passing through the filter the light is converted into a stream of light pulses by a chopper. Then the light is directed via a quartz fiber through a focusing lens and a slit to the beam divider. The beam divider divides the light into two parts. A specified portion is reflected to the reference detector, which monitors the light level

fluctuations. The remaining major portion of the light beam goes through the liquid in the cell to the signal detector, which measures the amount of light absorbed.

- 3.33 Precision – The degree to which a set of observations or measurements of the same property, obtained under similar conditions, conform to themselves; a data quality indicator. Precision is usually expressed as standard deviation, variance or range, in either absolute or relative terms. (NELAC)
- 3.34 Preservation – Refrigeration, freezing, and/or reagents added at the time of sample collection (or later) to maintain the chemical and or biological integrity of the sample.
- 3.35 Quality Control Sample (QCS) – A sample of analyte of known and certified concentration. The QCS is obtained from a source external to the laboratory and different from the source of calibration standards. It is used to check laboratory performance with externally prepared test materials. Also referred to as CRM.
- 3.36 Run Cycle – Typically a day of operation – the entire analytical sequence from sampling the first standard to the last sample of the day.
- 3.37 Sample Segment – Bar-coded metal tray that holds up to fourteen four milliliter auto analyzer vials containing samples or standards. The user identifies each vial in the operating software.
- 3.38 Sample Segment Holder – An automated temperature controlled carousel that contains up to six sample segments. This carousel spins in clockwise or counterclockwise manner to move the sample segments into position for analysis. This carousel format allows for continuous processing.
- 3.39 Sensitivity – The capability of a test method or instrument to discriminate between measurement responses representing different levels (concentrations) of a variable of interest.
- 3.40 Shall – Denotes a requirement that is mandatory whenever the criterion for conformance with the specification requires that there be no deviation. (ANSI)
- 3.41 Should – Denotes a guideline or recommendation whenever noncompliance with the specification is permissible. (ANSI)
- 3.42 Standard Reference Material (SRM) – Material which has been certified for specific analytes by a variety of analytical techniques and/or by numerous laboratories using similar analytical techniques. These may consist of pure chemicals, buffers, or compositional standards. The materials are used as an indication of the accuracy of a specific analytical technique. Also referred to as CRM.
- 3.43 Test Definition – A photometric test consisting of a user defined testing sequence, reagent additions, calibration standards, incubations and absorption results.
- 3.44 Test Flow – Functions to define the parameter for reagent and sample dispensing, dilution, incubation and measurement.

4 INTERFERENCES

- 4.1 Suspended matter in the sample will scatter light as it passes through the cuvette to the detector. High blank responses will result. The identified sample will be reanalyzed.
- 4.2 Blemishes in the cuvette, as result of the manufacturing process, will result in high blank responses. The identified sample will be reanalyzed.
- 4.3 Seawater contains calcium and magnesium ions in sufficient concentrations to cause precipitation during analysis, reducing color production. Adding sodium potassium tartrate and sodium citrate reduces the interference.
- 4.4 Eliminate any added acidity in samples because intensity of measured color is pH-dependent.

5 SAFETY

- 5.1 Safety precautions must be taken when handling reagents, samples and equipment in the laboratory. Protective clothing including lab coats, safety glasses and enclosed shoes must be worn. In certain situations, it will be necessary to also use gloves and/or a face shield. If solutions come in contact with eyes, flush with water continuously for 15 minutes. If solutions come in contact with skin, wash thoroughly with soap and water. Contact Solomons Rescue Squad (911) if emergency treatment is needed and also inform the CBL Associate Director of Administration and Facilities Maintenance of the incident. Contact the CBL Associate Director of Administration and Facilities Maintenance if additional treatment is required.
- 5.2 The toxicity or carcinogenicity of each reagent used in this procedure may not have been fully established. Each chemical should be regarded as a potential health hazard and exposure should be as low as reasonably achievable. Cautions are included for known hazardous materials and procedures.
- 5.3 Do not wear jewelry when troubleshooting electrical components. Even low voltage points are dangerous and can injure if allowed to short circuit.
- 5.4 The following hazard classifications are listed for the chemicals used in this procedure. Detailed information is provided on Material Safety Data Sheets (MSDS).

Table 1

Chemical	Health Hazard	Fire Hazard	Instability Hazard	Specific Hazard	
Sodium potassium tartrate	1	1	0		
Sodium citrate	1	1	0		
Sulfuric acid	4	0	2	ACID, COR	
Phenol	1	0	1		
Sodium hydroxide	3	0	1	ALK, COR	
Sodium nitroprusside	2	0	0		
Sodium hypochlorite (Clorox)	3	0	0		
Ammonium sulfate	2	0	0		
Chloroform	3	0	0		

On a scale of 0 to 4 the substance is rated on four hazard categories: health, flammability, reactivity, and contact. (0 is non-hazardous and 4 is extremely hazardous)

HAZARD RATING

Health Hazard - Blue: 4 – deadly, 3 – extreme danger, 2 – hazardous, 1 – slightly hazardous, 0 – normal material

Fire Hazard - Red: Flash Points: 4 – below 73° F, 3 – below 100° F, 2 – below 200° F, 1 – above 200° F, 0 – will not burn

Instability Hazard - Yellow: 4 – may detonate, 3 – Shock and heat may detonate, 2 – violent chemical change, 1 – unstable is heated, 0 - stable

Specific Hazard - White: Acid = ACID, Alkali = ALK, Corrosive = COR, Oxidizer = OXY

6 EQUIPMENT AND SUPPLIES

- 6.1 Aqaquem 250 multi-wavelength automated discrete photometric analyzer.
 Aqaquem 250 control software operates on a computer running Microsoft Windows NT,XP, or 7 operating system.
- 6.2 Freezer, capable of maintaining $-20 \pm 5^{\circ}$ C.

6.3 Lab ware – All reusable lab ware (glass, Teflon, plastic, etc) should be sufficiently clean for the task objectives. This laboratory cleans all lab ware related to this method with a 10% HCl (v/v) acid rinse.

7 REAGENTS AND STANDARDS

7.1 Purity of Water – Unless otherwise indicated, references to water shall be understood to mean reagent water conforming to Specification D 1193, Type I. Freshly prepared water should be used for making the standards intended for calibration. The detection limits of this method will be limited by the purity of the water and reagents used to make the standards.

7.2 Purity of Reagents – Reagent grade chemicals shall be used in all tests. Unless otherwise indicated, it is intended that all reagents shall conform to specifications of the Committee on Analytical Reagents of the American Chemical Society, where such specifications are available. Other grades may be used, provided it is first ascertained that the reagent is of sufficiently high purity to permit its use without compromising the accuracy of the determination.

7.3 Complexing reagent

Sodium potassium tartrate ($\text{KNaC}_4\text{H}_4\text{O}_6 \cdot 4\text{H}_2\text{O}$)	19.5 g
Sodium citrate ($\text{C}_6\text{H}_8\text{N}_2 \text{O}_2\text{S}$)	14.0 g
Sulfuric acid (H_2SO_4), concentrated (sp. gr. 1.84)	as required

In a 1000 mL beaker, dissolve 19.5 g sodium potassium tartrate and 14.0 g sodium citrate in approximately 500 mL reagent water. Place on heated magnetic stir plate. After dissolution, add 1 mL 5M NaOH and allow to boil uncovered until volume is reduced to 300 mL. Remove from heat, cool and add 1 mL 5N HCl. Bring volume to ~400 mL with reagent water and adjust the pH of the solution to 5.0 using concentrated sulfuric acid. Transfer solution to a 500 mL volumetric flask and bring to volume with reagent water. Write name of preparer, preparation date, reagent manufacturer, manufacturer's lot number in the Analytical Reagent log book. Store flask in dark at room temperature. Reagent is stable for six months.

7.4 Alkaline phenol solution

Phenol ($\text{C}_6\text{H}_5\text{OH}$), 88%	23.6 mL
Sodium hydroxide (NaOH), 50% (w/w)	18.0 g

In a 250 mL volumetric flask, slowly add 23.6 mL of 88% phenol to approximately 150 mL reagent water. While in an ice bath, add exactly 18 g of 50% (w/w) sodium hydroxide to the phenol/water solution. Bring flask to volume with reagent water. Store reagent in light resistant container in refrigerator. Write name of preparer, preparation date, reagent manufacturer, manufacturer's lot number in the Analytical Reagent log book. Reagent is stable for two weeks.

WARNING: Phenol is extremely dangerous and should be handled accordingly. Prepare in an operating fume hood wearing protective gloves.

7.5 Sodium hypochlorite, 1% –

Sodium hypochlorite (Clorox Regular – 8.25%) 32 mL
Reagent water 200 mL

In a 250 mL brown poly bottle, dilute 32 mL of commercially available bleach containing 8.25% sodium hypochlorite with 200 mL reagent water. Write name of preparer, preparation date, manufacturer, date Clorox purchased in the Analytical Reagent log book. Reagent is stable for two days at room temperature.

7.6 Sodium nitroprusside (Sodium nitroferricyanide), 0.05% –

Sodium nitroprusside 0.5 g
Reagent water up to 1000 mL

In a 1000 mL flask, dissolve 0.5 g of sodium nitroprusside in 900 mL reagent water. Dilute to 1000 mL with reagent water and transfer to brown poly bottle. Write name of preparer, preparation date, reagent manufacturer, manufacturer lot number in the Analytical Reagent log book. Reagent is stable for 12 months at room temperature.

7.7 Ammonium Stock Standard, 1,500 μ M –

Ammonium Sulfate [(NH₄)₂SO₄], primary standard grade, dried at 45°C
0.0501 g
Reagent water up to 500 mL

In a 500 mL volumetric flask, dissolve 0.0501 g of ammonium sulfate in ~400 mL of reagent water. Dilute to 500 mL with reagent water (1 mL contains 1.5 μ moles N). Transfer to glass bottle. Add 1 mL of chloroform as a preservative. Write name of preparer, preparation date, standard manufacturer, manufacturer lot number in the Analytical Standard log book. Store at room temperature. Make fresh every 6 months.

7.8 Working Ammonium Standard –

Stock Ammonium Standard 0.80 mL
Reagent water up to 100 mL

In a volumetric flask, dilute 0.80 mL of Stock Ammonium Standard to 100 mL with reagent water to yield a concentration of 12 μ M NH₄ –N/L (0.168 mg N/L). Write name of preparer, preparation date, Ammonium Stock Standard preparation date in the Analytical Standard log book. Make fresh every month.

7.9 Working High Ammonium Standard –

Stock Ammonium Standard 8.00 mL
Reagent water up to 100 mL

In a volumetric flask, dilute 8.00 mL of Stock Ammonium Standard to 100 mL with reagent water to yield a concentration of 120 μ M NH₄ –N/L (1.68 mg N/L). Write name of preparer, preparation date, Ammonium Stock Standard preparation date in the Analytical Standard log book. Make fresh every month.

- 7.10 Aquakem Cleaning Solution –
Clorox 55.0 mL
In a 100 mL volumetric flask, dilute 55.0 mL of Clorox to volume with reagent water to yield a concentration of 75% Clorox. Write name of preparer, preparation date, reagent manufacturer, manufacturer lot number in the Analytical Reagent log book. Reagent is stable for six months.

8 SAMPLE COLLECTION, PRESERVATION, AND STORAGE

- 8.1 Water collected for ammonium should be filtered through a Whatman GF/F glass fiber filter (nominal pore size 0.7 μm), or equivalent.
- 8.2 Water collected for ammonium should be measured for salinity.
- 8.3 Water collected for ammonium should be frozen at $\leq -20^{\circ}\text{C}$. The AutoAnalyzer vial container (sample cups) should be clean and sample rinsed.
- 8.4 Frozen ammonium samples may be stored up to 28 days. It has been shown that frozen QCS samples up to a year old still fall well within the control limits.
- 8.5 Ammonium samples may be refrigerated at 4°C for no longer than one day.

9 QUALITY CONTROL

- 9.1 The laboratory is required to operate a formal quality control (QC) program. The minimum requirements of this program consist of an initial demonstration of laboratory capability and the continued analysis of laboratory instrument blanks and calibration standard material, analyzed as samples, as a continuing check on performance. The laboratory is required to maintain performance records that define the quality of data generated.
- 9.2 Initial Demonstration of Performance
- 9.2.1 The initial demonstration of capability (iDOC)– is used to characterize instrument performance (MDLs) and laboratory performance (analysis of QC samples) prior to the analyses conducted by this procedure.
- 9.2.2 Linear Dynamic Range – LDR (Linear Calibration Range) should be established for ammonium using appropriate five point calibration curve.
- 9.2.3 Quality Control Sample (QCS/SRM) – When using this procedure, a quality control sample is required to be analyzed at the beginning and end of the run, to verify data quality and acceptable instrument performance. If the determined concentrations are not within $\pm 3s$ of the certified values, performance of the determinative step of the

method is unacceptable. The source of the problem must be identified and corrected before either proceeding with the initial determination of MDLs or continuing with analyses.

- 9.2.4 Method Detection Limits (MDLs) – MDLs should be established for ammonium using a low level natural water sample. To determine the MDL values, analyze seven replicate aliquots of water and process through the entire analytical procedure. Perform all calculations defined in the procedure (Section 12) and report the concentration values in the appropriate units. Calculate the MDL as follows: $MDL = S t_{(n-1, 1-\alpha=0.99)}$

Where, S = Standard deviation of the replicate analyses.
 n = number of replicates
 $t_{(n-1, 1-\alpha=0.99)}$ = Student's t value for the 99% confidence level with $n-1$ degrees of freedom ($t=3.14$ for 7 replicates.)

- 9.2.5 MDLs shall be determined yearly and whenever there is a significant change in instrument response or a significant change in instrument configuration.

9.3 Assessing Laboratory Performance

- 9.3.1 Laboratory Reagent Blank (LRB) – The laboratory must analyze at least one LRB with each batch of samples. The LRB consists of Nanopure water treated the same as the samples. Analyte found in LRB indicates possible reagent or laboratory environment contamination. LRB data are used to assess and correct contamination from the laboratory environment
- 9.3.2 Quality Control Sample (QCS)/ Standard Reference Material (SRM) – When using this procedure, a quality control sample is required to be analyzed at the beginning of the run and end of the run, to verify data quality and acceptable instrument performance. If the determined concentrations are not within $\pm 3s$ of the certified values, performance of the determinative step of the method is unacceptable. The source of the problem must be identified and corrected before either proceeding with the initial determination of MDLs or continuing with the analyses. The results of these QCS/SRM samples shall be used to determine batch acceptance.
- 9.3.3 The QCS are obtained from a source external to the laboratory and different from the source of calibration standards.
- 9.3.4 Control Charts – The Accuracy Control Chart for QCS/SRM samples and reagent blanks is constructed from the average and standard deviation of the 20 most recent QCS/SRM measurements. The accuracy chart includes upper and lower warning levels ($WL=\pm 2s$) and upper and lower control levels ($CL=\pm 3s$). These values are derived

from stated values of the QCS/SRM. The standard deviation (s) is specified relative to statistical confidence levels of 95% for WLs and 99% for CLs. Enter QCS/SRM results on the chart each time the sample is analyzed

- 9.3.5 Calibration Verification, Initial and Continuing (ICV/CCV) – Immediately following calibration (ICV) and following every 18-23 samples (CCV), one calibration verification of 6.0 μM $\text{NH}_4\text{-N/L}$ (0.126 mg N/L) NH_4 , 60 μM $\text{NH}_4\text{-N/L}$ (1.26 mg N/L) NH_4HIGH , is analyzed to assess instrument performance. The CCVs are made from the same material as calibration standards $[(\text{NH}_4)_2\text{SO}_4]$, and are to be within the expected value $\pm 3s$. Failure to meet the criteria requires correcting the problem, including reanalysis of any affected samples. If not enough sample exists, the data must be qualified if reported.

9.4 Assessing Analyte Recovery - Percent Recovery

- 9.4.1 Analyte recovery is assessed through percent recoveries of laboratory spikes of samples.
- 9.4.2 Percent Recovery = (Actual value/Expected value) X 100.

9.5 Assessing Analyte Precision – Relative Percent Difference

- 9.5.1 Analyte replication is assessed through duplicate analyses of samples – Relative Percent Difference.
- 9.5.2 $\text{RPD} = (\text{Laboratory Duplicate Result 1} - \text{Laboratory Duplicate Result 2}) / [(\text{Laboratory Duplicate Result 1} + \text{Laboratory Duplicate Result 2}) / 2] \times 100$

9.6 Corrective Actions for Out of Control Data

- 9.6.1 Control limit – If one measurement exceeds Accuracy Control Chart CL, repeat the analysis immediately. If the repeat measurement is within the CL, continue analyses; if it exceeds the CL, discontinue analyses and correct the problem.
- 9.6.2 Warning limit – If two out of three successive points exceed Accuracy Control Chart WL, analyze another sample. If the next point is within WL, continue analyses; if the next point exceeds the WL, evaluate potential bias and correct the problem.
- 9.6.3 Trending – If seven successive Accuracy Control Chart measurements are on the same side of the central line, discontinue analyses and correct the problem.
- 9.6.4 When external QCS samples are out of control, correct the problem. Reanalyze the samples analyzed between the last in-control measurement and the out-of-control one.
- 9.6.5 When external CCV samples are out of control, correct the problem. Reanalyze the samples analyzed between the last in-control measurement and the out-of-control one.

9.7 General Operation - To assure optimal operation and analytical results, the Reagent Blank and CCV are tracked daily in the raw data file, copied to Reagent Blank and CCV Control Charts.

Table 2

QC Indicator	Acceptance/ Action Limits	Action	Frequency (Batch)
Correlation Coefficient	≥ 0.995	If <0.995 , evaluate data points of the calibration curve. If any data point is outside established limits, reject as outlier.	1 per batch if acceptable.
Quality Control Sample (QCS)/ Certified Reference Material (CRM)	$\pm 10\%$	If QCS value is outside $\pm 10\%$ of the target value reject the run, correct the problem and rerun samples.	Beginning of run and at end of run.
Initial Calibration Verification (ICV)	$\pm 10\%$	Recalibrate if outside acceptance limits.	Beginning of run following standard curve.
Continuing Calibration Verification (CCV)	$\pm 10\%$	If outside 10%, correct the problem. Rerun all samples following the last in-control CCV.	After every 18-23 samples.
Method Blank/Laboratory Reagent Blank (LRB)	\leq Method Quantitation Limit	If the LRB exceeds the quantitation limit, results are suspect. Rerun the LRB. If the concentration still exceeds the quantitation limit, reject or qualify the data, or raise the quantitation limit.	Following the ICV and after every 18-23 samples following the CCV.
Laboratory Fortified Sample Matrix Spike	$\pm 10\%$	If the recovery of any analyte falls outside the designated acceptance limits and the QCS is in control, the recovery problem is judged matrix induced. Repeat the LFM and if the sample results are again outside the acceptable recovery range, the sample should be reported with a "matrix induced bias" qualifier.	1/10 (spike OR duplicate)

Laboratory Duplicate	± 10%	If the RPD fails to meet the acceptance limits, the samples should be reanalyzed. If the RPD again fails to meet the acceptance limits, the sample must be reported with a qualifier identifying the sample analysis result as not having acceptable RPD for duplicate analysis.	1/10 (spike OR duplicate)
----------------------	-------	--	---------------------------

10 CALIBRATION AND STANDARDIZATION

10.1 Calibration – Daily calibration must be performed before sample analysis may begin. Six or seven point calibrations are used with each of the two sub-calibrations that cover the analytical range. Two working ammonium standards are used to produce the calibrators for each set of two calibration curves. The instrument performs serial dilutions of working standards to produce the six or seven calibrators defined for each curve. The following outlines the preparation of the working standards and the following table describes the subsequent serial dilutions the instrument performs to make each standard for each of the two calibration curves.

Ammonium Working Standards:

NH4 (NH4CBL2)

Working Standard 0.168 mg N/L (0.8 mL stock standard to 100 mL)

Working CCV 0.126 mg N/L (0.6 mL stock standard to 100 mL)

NH4HIGH

Working Standard 1.68 mg N/L (8.0 mL stock standard to 100 mL)

Working CCV 1.26 mg N/L (6.0 mL stock standard to 100 mL)

Table 3 Ammonium Calibrators:

Test Name	Working Standard	Dilution Factor	Concentration mg N/L
NH4CBL2	0.168 mg N/L	1+12	0.01292
	0.168 mg N/L	1+9	0.0168
	0.168 mg N/L	1+6	0.024
	0.168 mg N/L	1+4	0.0336
	0.168 mg N/L	1+2	0.056
	0.168 mg N/L	1+1	0.084
	0.168 mg N/L	1+0	0.168
NH4HIGH	1.68 mg N/L	1+9	0.168
	1.68 mg N/L	1+6	0.24

	1.68 mg N/L	1+3	0.42
	1.68 mg N/L	1+2	0.56
	1.68 mg N/L	1+1	0.84
	1.68 mg N/L	1+0	1.68

10.2 The instrument software prepares a standard curve for each set of calibrators. A graph plotting measured absorbance against standard concentration is presented for review and approval. If acceptance criteria are not met the entire curve can be reanalyzed or individual standards can be reanalyzed. One standard value (original or reanalyzed) for each and every standard is incorporated in the curve. The coefficient of determination (Pearson's r value) for the calibration curve as well as the calculated concentration of each calibrator is reviewed. The calculated value of each calibrator must be within ten percent of the expected value. The coefficient of determination (Pearson's r value) for the calibration curve must be greater than 0.9950.

11 PROCEDURE – DAILY OPERATIONS QUALITY CONTROL

- 11.1 Turn on computer. Computer will automatically initiate Konelab software. Once software is running, turn on instrument and allow connection between instrument and computer to complete.
- 11.2 Discard any water remaining in the water reservoir from the previous analytical run. Fill the water reservoir with fresh reagent water.
- 11.3 Remove samples from freezer to be analyzed. Allow samples to begin thawing. Begin daily bench sheet documentation.
- 11.4 Place cuvette waste box into cuvette waste sliding drawer.
- 11.5 Once water reservoir is full, use instrument software to click More, Instrument Actions, and Perform Water Wash.– complete at least five perform water wash cycles
- 11.6 After performing water washes, clean the dispensing needle by performing test washes. Click More, Instrument Actions, More, Adjustment Program. Once in the Adjustment Program click, 4-Dispensing Unit, 1-Dispenser, 8-Test Wash. Perform 8 to 10 Test Washing. When complete, press “Q” to quit until you are able to bring up the Main Page.
- 11.7 Perform Start Up operations by clicking Start Up at the bottom of the Main Page.
- 11.8 Gather working standards and reagents from refrigerator or dark cabinet under sink during startup. Assess standards and reagents. Remake anything that has exceeded the time over which it is considered stable.
- 11.9 Once startup is complete, check the instrument water blanks by clicking More, Instrument Actions, More, Check Water Blank. If any of the instrument blanks are outside their predefined and software controlled limits, the user will be notified on the main menu page. User takes corrective action to return instrument functions to controlled limits.

- 11.10 Load reagents in specified position in reagent carousel and place in refrigerated reagent compartment. Reagent positions can be found by clicking reagents at the top of the main page.
- 11.11 Load working standards in a sample segment, identify the standards in their positions from the drop down menus at the individual segment positions, and load into instrument. . (Click Samples from the top of the Main Page, then click desired segment number.)
- 11.12 Select the methods to be calibrated by clicking Calibr./QC Selection on the bottom of the main page. Click NH4CBL2, and NH4HIGH as the two methods to be calibrated, then click Calibrate at the bottom of the page. The two methods will now show as pending. Return to the main page..
- 11.13 Start instrument and calibration by clicking Page Up on the keyboard. This may also be a green button on the keyboard – See test flow below for stepwise instrument functions for the analysis of standards and samples.

Test Flow – Method of Analysis, Stepwise

- 100 µL sample to cuvette with mixing
 - 55 µL Complexing Reagent to cuvette with mixing
 - 33 µL Alkaline Phenol Reagent to cuvette with mixing
 - Blank response measurement at 630 nm
 - 26 µL Sodium Hypochlorite Reagent to cuvette with mixing
 - 33 µL Sodium Nitroprusside Reagent to cuvette with mixing
 - Incubation, 420 seconds, 37°C
 - End point absorbance measurement, 630 nm
 - Software processes absorbance value, blank response value and uses calibration curve to calculate analyte concentration (mg/L N as NH₄)
 - User is notified if any measured values used to calculate final concentration are outside preset limits. If so, analyst has options to accept result, rerun the sample or rerun the sample diluted to a user or software specified factor.
 - User is notified of each blank response value. Blank response >0.005 absorbance units indicates a scratched cuvette or turbid sample. If the blank response value exceeds 0.005 absorbance units, the analyst specifies that the sample is reanalyzed. If the blank response value of the reanalyzed sample is <0.005 absorbance units, the reanalyzed result is accepted. If the same concentration and blank response value >0.005 absorbance units is again obtained, the results are accepted.
- 11.14 Organize samples, reagent blanks, check standards and all quality control samples while instrument performs calibrations.
- 11.15 As calibration curves are produced by the instrument, review them for acceptability. The instrument software prepares a standard curve for each set of calibrators. A graph plotting measured absorbance against standard concentration is presented for review and approval. If acceptance criteria are not met, either the entire curve shall be reanalyzed or individual standards shall be reanalyzed,

- depending on the violation. One standard value (original or reanalyzed) for each and every calibrator is incorporated in the curve.
- 11.16 Once calibration curves are accepted, samples are loaded into the sample segments and loaded into the instrument for analysis. After the Reagent Blank, the first sample analyzed should be an ICV (initial calibration verification) sample. There should be one ICV sample for each calibration curve, of a concentration close to the middle of each range. The following are recommended ICV samples for each curve: 0.126 mg N/L for NH4CBL2 and 1.26 mg N/L for NH4HIGH.
 - 11.17 Samples are loaded into the segments and analyzed. CCV (Continuing Calibration Verification) samples (one for each of the two calibration ranges) follow every 18-23 samples. Standard Reference Material (SRM) samples, as well as Laboratory Reagent Blanks (LRB) are scattered throughout the analytical batch. Throughout the analytical batch, samples are chosen as laboratory duplicates and laboratory spikes to assess analyte precision and analyte recovery, respectively. The total number of duplicates and spikes performed will be equal or greater to ten percent of the total number of samples in the analytical batch.
 - 11.18 As sample analysis is complete, results must be reviewed and accepted manually. If results fall outside acceptance limits, the sample should be reanalyzed. If sample result exceeds the highest standard of the highest calibration range, the samples can be automatically diluted by the instrument and reanalyzed. If the result is such that it will fall within a higher calibration range, it should be reanalyzed in the higher range. If the result is such that it will fall within a lower calibration range, it should be reanalyzed within the lower range.
 - 11.19 User reviews salinity of samples. If any sample salinity concentration is greater than 20 ppt, the analyst reanalyzes the sample diluted to a user specified factor to obtain a salinity ≤ 10 ppt.
 - 11.20 Upon completion of all analysis, results are saved to a daily report file. Click Report on the bottom of the main page, More, Results To File, and select one row per result. The file is then named by the run date. The daily report file for analytical batch of January 1, 2017 would be named 010117. The file is converted to Microsoft Excel for data work up. Remaining samples are discarded.
 - 11.21 All reagents are removed from the reagent chamber and returned to the refrigerator or dark cabinet. Reagents that have exceeded their stability period are discarded.
 - 11.22 Click on Stand By on the bottom of the main page and insert Aquakem Cleaning Solution into the instrument. This initiates shut down procedures. Daily files are cleared from the instrument software by clicking More, Management, Clear Daily Files. The software is exited and the instrument is turned off. The computer is turned off.
 - 11.23 The waste is flushed down the drain with copious amounts of tap water. The waste cuvette box is moved to the fume hood and covered.

12 DATA ANALYSIS AND CALCULATIONS

- 12.1 Upon completion of all analysis, results are saved to a daily report file. The file is named by the run date. The daily report file for analytical batch of January 1, 2017 would be named 010117. The file is converted to Microsoft Excel for data work up. The instrument software has calculated final sample concentration from the designated standard curve, correcting each concentration for associated blank response and also for any user or instrument specified dilution. Dilution by the instrument is noted by software as analysis ensues and, also, documented in the Excel data report file. The analyst examines each row of data. Results are eliminated that are outside the limits of the calibration range, or have an unrepeated blank response measurement greater than 0.005 absorbance units.
- 12.2 The analyst examines all sample salinities provided by the client. Observed results for samples with salinities ≥ 20 ppt are mathematically corrected using an empirically derived equation (see appendix A for description), which is applied to the original undiluted observed concentration. If the undiluted sample with salinity ≥ 20 ppt requires dilution to bring the observed concentration into the appropriate analytical range the observed value is not subject to correction as the sample salinity resulting from the dilution will be less than 20ppt.

13 REFERENCES

- 13.1 Frank, J. M., C.F. Zimmermann and C. W. Keefe (2006). Comparison of results from Konelab Aquakem 250 and existing nutrient analyzers. UMCES CBL Nutrient Analytical Services Laboratory, Dec. 2006.
- 13.2 Solorzano, L. 1969. Determination of ammonia in natural waters by the phenolhypochlorite method. *Limnol. Oceanogr.* 14:799-801.
- 13.3 Parsons, T.R., Y. Maita and C.M. 1984. *A Manual of Chemical and Biological Methods for Seawater Analysis*, Pergamon Press, Elmsford, N.Y.
- 13.4 Kerouel, R. and A. Aminot. 1987. Procédure optimisée hors-contaminations pour l'analyse des éléments nutritifs dissous dans l'eau de mer. *Mar. Environ. Res* 22:19-32.

Appendix A

Ammonium determination in seawater employing indophenol blue requires correction for higher salinity samples due to the salt effect of magnesium ions diminishing the production of blue color. The ability of sodium potassium citrate and sodium citrate to mitigate this effect weakens at higher salinities. Full strength and diluted seawater from the Drake Passage (between South America and Antarctica) was employed to measure the extent of this effect. Drake Passage water has virtually no ammonium. Samples of Drake Passage water were diluted to varying salinities and their ammonium concentration measured. The samples were also spiked with ammonium standard, measured for ammonium and compared with standards prepared in reagent water. These experiments were repeated with freshly made standards and spiked water on twelve different days. From the data a regression equation (Figure 1) was established to correct high salinity ammonium data. The correction is insignificant and becomes unnecessary for sample salinities below 20 ppt.. Ammonium spikes of high salinity water from Maryland Coastal Bays yielded the same relationships as the Drake Passage data.

As NASL routinely encounters broad salinity ranges within a single analytical batch the follow equation, derived from this experiment, is applied to undiluted observed values of samples with salinities ≥ 20 ppt.

Salinity Corrected mg NH₄-N/L= (((100-((-1.14 X ppt sample salinity) +116))/100) +1) X uncorrected mg NH₄-N/L)

UNIVERSITY OF MARYLAND CENTER FOR ENVIRONMENTAL SCIENCE
CHESAPEAKE BIOLOGICAL LABORATORY
NUTRIENT ANALYTICAL SERVICES LABORATORY
146 Williams St., Solomons MD 20688
<http://nasl.cbl.umces.edu/>

**Standard Operating Procedure for
Determination of Dissolved Inorganic Nitrate plus Nitrite (NO₃+NO₂) in
Fresh/Estuarine/Coastal Waters Using Cadmium Reduction
(References EPA 353.2)**

**Revision 2017-2
Replaces Revision 2015
Effective April 26, 2017**

Revised by: _____ Date: _____

Reviewed by: _____ Date: _____

Laboratory Supervisor: _____ Date: _____

Changes affecting Revision 2015

Section 1.2: Inserted If more than seven replicates are used to determine the MDL, refer to the Student's *t* test table for the appropriate n-1 value.

Section 1.4: Inserted See Appendix 1 for addition ranges and configurations for this method.

Section 1.7: Used references instead of conforms

Section 3.4: Inserted See Appendix 1 for addition ranges and configurations for this method., Added the word for

Section 3.5: Deleted preparation batch definition

Section 3.24: Deleted Instrument Detection Limit

Entire Document: Changed deionized water to reagent water

Section 3.27: Added This is also referred to as MDL.

Section 3.28: Added This is also referred to as the Quantitation Limit

Section 3.37: Changed proscribed to prescribed

Section 3.38: Added Also referred to as CRM

Section 3.45: Added Also referred to as CRM

Section 5.1 Changed the word should to must, Changed CBL Business Manager to the CBL Associate Director of Administration and Facilities Maintenance

Section 5.4: Updated Chemical Safety Table (Table 1)

Section 7.6: Changed Color Reagent to be made in 500 ml instead of 1L

Section 7.7: Changed KNO₃ standard to be made in 500 ml instead of 1L

Section 7.10: Changed NaNO₂ standard to be made in 500 ml instead of 1L

Section 8.1: Added ≤ sign for freezer temp

Section 8.2: Added the words sample cups

Section 9.2.1: Changed the initial demonstration of capability acronym to iDOC

Section 9.2.4: Deleted from MDL description the change of operator or a new matrix is encountered, changed ambient water to natural water

Section 9.3.1: Deleted LRB above the MDL requires that the source of the problem must be identified and corrected before proceeding with analysis

Section 9.3.4: Added the words reagent blanks, deleted Set up an accuracy chart by using percent recovery since the concentration of the QCS/SRM varies

Section 9.3.5: Added ICV information to the CCV, Added See Appendix 1 for additional CCVs.

Section 9.3.6: Changed TV to the expected value

Section 9.3.7: Removed reagent blank description

Section 9.4: Changed % to read PercentSection 9.7: Added Table 2

Section 10.3: Added the coefficient of determination (Pearson's *r* value) for the calibration curve as well as the calculated concentration of each calibrator is reviewed. The calculated value of each calibrator must be within ten percent of the expected value. The coefficient of determination (Pearson's *r* value) for the calibration curve must be greater than 0.995.

Section 11.25: Changed the standards from 40uM to 35uM

Section 11.28: Changed the standards from 40uM to 35uM

Section 12.2: Changed warm up from 1 hour to 45min

Section 12.6: Added the step Analyze CRM sample by dilution in order for the concentration to be in the middle of the calibration curve.

Section 12.10: Added the step Analyze CRM sample by dilution in order for the concentration to be in the middle of the calibration curve.

Section 14: Removed Method Performance

Appendix 1: Added Appendix 1

Determination of Dissolved Inorganic Nitrate plus Nitrite (NO₃+NO₂) in Fresh/Estuarine/Coastal Waters Using Cadmium Reduction

1. SCOPE and APPLICATION

- 1.1 Cadmium reduction is used to quantitatively reduce dissolved nitrate to nitrite which is then measured by colorimetric quantitative analysis of a highly colored azo dye. The method is used to analyze all ranges of salinity.
- 1.2 A Method Detection Limit (MDL) of 0.0007 mg NO₃+NO₂-N/L was determined using the Student's *t* value (3.14, n=7) times the standard deviation of a minimum of 7 replicates. If more than seven replicates are used to determine the MDL, refer to the Student's *t* test table for the appropriate n-1 value.
- 1.3 The Quantitation Limit for NO₃+NO₂ was set at 0.0035 mg NO₃+NO₂-N/L.
- 1.4 The method is suitable for NO₃+NO₂ concentrations 0.0007 to 0.056 mg NO₃+NO₂-N/L. See Appendix 1 for addition ranges and configurations for this method.
- 1.5 This procedure should be used by analysts experienced in the theory and application of aqueous inorganic analysis. A three month training period with an analyst experienced in the analysis of nitrate plus nitrite in aqueous samples by cadmium reduction is required.
- 1.6 This method can be used for all programs that require analysis of dissolved inorganic nitrate plus nitrite.
- 1.7 This procedure references EPA Method 353.2 (1979).

2. SUMMARY

2.1 Filtered samples are passed through a granulated copper-cadmium column to reduce nitrate to nitrite. The nitrite, both that which was reduced from nitrate and nitrite that was originally present, is then determined by diazotizing with sulfanilamide and coupling with N-1-naphthylethylenediamine dihydrochloride to form a colored azo dye.

3. DEFINITIONS

- 3.1 Acceptance Criteria – Specified limits placed on characteristics of an item, process, or service defined in a requirement document. (ASQC)
- 3.2 Accuracy – The degree of agreement between an observed value and an accepted reference value. Accuracy includes a combination of random error (precision) and systematic error (bias) components which are due to sampling and analytical operations; a data quality indicator. (QAMS)
- 3.3 Aliquot – A discrete, measured, representative portion of a sample taken for analysis. (EPA QAD Glossary)

- 3.4 Analytical Range – 0.0056 to 0.056 mg NO₃+NO₂-N/L, using black/black sample pump tube and yellow/yellow ammonium chloride diluent pump tube at a Standard Calibration setting of 9.00. See Appendix 1 for additional concentration ranges and configurations.
- 3.5 Batch – Environmental samples, which are prepared and /or analyzed together with the same process and personnel, using the same lot(s) of reagents. An **analytical batch** is composed of prepared environmental samples (extracts, digestates, or concentrates) and/or those samples not requiring preparation, which are analyzed together as a group using the same calibration curve or factor. An analytical batch can include samples originating from various environmental matrices and can exceed 20 samples. (NELAC/EPA)
- 3.6 Blank- A sample that has not been exposed to the analyzed sample stream in order to monitor contamination during sampling, transport, storage or analysis. The blank is subjected to the usual analytical and measurement process to establish a zero baseline or background value and is sometimes used to adjust or correct routine analytical results. (ASQC)
- 3.7 Calibrate- To determine, by measurement or comparison with a standard, the correct value of each scale reading on a meter or other device, or the correct value for each setting of a control knob. The levels of the applied calibration standard should bracket the range of planned or expected sample measurements. (NELAC)
- 3.8 Calibration – The set of operations which establish, under specified conditions, the relationship between values indicated by a measuring device. The levels of the applied calibration standard should bracket the range of planned or expected sample measurements. (NELAC)
- 3.9 Calibration Blank – A volume of reagent water fortified with the same matrix as the calibration standards, without analyte added.
- 3.10 Calibration Curve – The graphical relationship between known values, such as concentrations, or a series of calibration standards and their analytical response. (NELAC)
- 3.11 Calibration Method – A defined technical procedure for performing a calibration. (NELAC)
- 3.12 Calibration Standard – A substance or reference material used to calibrate an instrument. (QAMS)
- 3.12.1 Initial Calibration Standard (STD) – A series of standard solutions used to initially establish instrument calibration responses and develop calibration curves for individual target analytes.
- 3.12.2 Initial Calibration Verification (ICV) – An individual standard, distinct from the Initial Calibration Standards (STD), analyzed initially, prior to any sample analysis, which verifies acceptability of the calibration curve or previously established calibration curve.

- 3.12.3 Continuing Calibration Verification (CCV) – An individual standard which is analyzed after every 18-23 field sample analysis.
- 3.13 Certified Reference Material – A reference material one or more of whose property values are certified by a technically valid procedure, accompanied by or traceable to a certificate or other documentation which is issued by a certifying body. (ISO 17025)
- 3.14 Colorimeter – Detector found in Bran & Luebbe Single-Channel Industrial Colorimeter. Color is quantitatively detected with 199-B021-01 phototubes using 550 nm monochromatic filters and 50 mm long flow cell with 1.5 mm internal diameter. Comparisons are made between signals from the colored solution in the flow cell to the signal of air in the reference cell. Signals from the Colorimeter are transmitted to a Recorder.
- 3.15 Corrective Action – Action taken to eliminate the causes of an existing nonconformity, defect or other undesirable situation in order to prevent recurrence. (ISO 8402)
- 3.16 Deficiency – An unauthorized deviation from acceptable procedures or practices. (ASQC)
- 3.17 Demonstration of Capability – A procedure to establish the ability of the analyst to generate acceptable accuracy. (NELAC)
- 3.18 Detection Limit – The lowest concentration or amount of the target analyte that can be determined to be different from zero by a single measurement at a stated degree of confidence.
- 3.19 Duplicate Analysis – The analyses of measurements of the variable of interest performed identically on two sub samples (aliquots) of the same sample. The results from duplicate analyses are used to evaluate analytical or measurement precision but not the precision of sampling, preservation or storage internal to the laboratory. (EPA-QAD)
- 3.20 External Standard (ES) – A pure analyte (potassium nitrate (KN O₃)) that is measured in an experiment separate from the experiment used to measure the analyte(s) in the sample. The signal observed for a known quantity of the pure external standard is used to calibrate the instrument response for the corresponding analyte(s). The instrument response is used to calculate the concentrations of the analyte(s) in the unknown sample.
- 3.21 Field Duplicates (FD1 and FD2) – Two separate samples collected at the same time and place under identical circumstances and treated exactly the same throughout field and laboratory procedures. Analyses of FD1 and FD2 provide a measure of the precision associated with sample collection, preservation and storage, as well as with laboratory procedures.
- 3.22 Field Reagent Blank (FRB) – A aliquot of reagent water or other blank matrix that is placed in a sample container in the laboratory and treated as a sample in all respects, including shipment to the sampling site, exposure to the sampling site conditions, storage, preservation,

and all analytical procedures. The purpose of the FRB is to determine if method analytes or other interferences are present in the field environment.

- 3.23 Holding time – The maximum time that samples may be held prior to analysis and still be considered valid. (40 CFR Part 136) The time elapsed from the time of sampling to the time of extraction or analysis, as appropriate.
- 3.24 Laboratory Duplicates (LD1 and LD2) – Two aliquots of the same sample taken in the laboratory and analyzed separately with identical procedures. Analyses of LD1 and LD2 indicate precision associated with laboratory procedures, but not with sample collection, preservation, or storage procedures.
- 3.25 Laboratory Reagent Blank (LRB) – A matrix blank (i.e., reagent water) that is treated exactly as a sample including exposure to all glassware, equipment, solvents, and reagents that are used with other samples. The LRB is used to determine if method analytes or other interferences are present in the laboratory environment, the reagents, or the instrument.
- 3.26 Laboratory Control Sample (LCS) – A sample matrix, free from the analytes of interest, spiked with verified known amounts of analytes from a source independent of the calibration standard or a material containing known and verified amounts of analytes. The LCS is generally used to establish intra-laboratory or analyst-specific precision and bias or to assess the performance of all or a portion of the measurement system. (NELAC)
- 3.27 Limit of Detection (LOD) – The lowest concentration level that can be determined by a single analysis and with a defined level of confidence to be statistically different from a blank. This is also referred to as MDL. (ACS)
- 3.28 Limit of Quantitation (LOQ) – The minimum levels, concentrations, or quantities of a target variable (target analyte) that can be reported with a specified degree of confidence. The LOQ is set at 3 to 10 times the LOD, depending on the degree of confidence desired. This is also referred to as the Quantitation Limit.
- 3.29 Linear Dynamic Range (LDR) – The absolute quantity over which the instrument response to an analyte is linear. This specification is also referred to as the Linear Calibration Range (LCR).
- 3.30 Manifold – The module whose configuration of glass connectors, fittings, mixing coils, tubing and Cadmium-Copper reduction column precisely reduces the nitrate in the sample to nitrite, followed by color production.
- 3.31 Material Safety Data Sheets (MSDS) – Written information provided by vendors concerning a chemical's toxicity, health hazards, physical properties, fire, and reactivity data including storage, spill, and handling precautions.

- 3.32 May – Denotes permitted action, but not required action. (NELAC)
- 3.33 Method Detection Limit (MDL) – The minimum concentration of an analyte that can be identified, measured, and reported with 99% confidence that the analyte concentration is greater than zero. (Standard Methods)
- 3.34 Must – Denotes a requirement that must be met. (Random House College Dictionary)
- 3.35 Precision – The degree to which a set of observations or measurements of the same property, obtained under similar conditions, conform to themselves; a data quality indicator. Precision is usually expressed as standard deviation, variance or range, in either absolute or relative terms. (NELAC)
- 3.36 Preservation – Refrigeration, freezing, and/or reagents added at the time of sample collection (or later) to maintain the chemical and or biological integrity of the sample.
- 3.37 Proportioning Pump – A peristaltic pump that mixes and advances samples and reagents through prescribed precision pump tubes proportionately for the reactions to take place and for the concentration to be measured.
- 3.38 Quality Control Sample (QCS) – A sample of analyte of known and certified concentration. The QCS is obtained from a source external to the laboratory and different from the source of calibration standards. It is used to check laboratory performance with externally prepared test materials. Also referred to as CRM.
- 3.39 Recorder – A graphic recorder used to record electronic output from the colorimeter.
- 3.40 Run Cycle – Typically a day of operation – the entire analytical sequence from sampling the first standard to the last sample of the day.
- 3.41 Sampler – An automated rotational device that moves sample cups sequentially to aspirate an aliquot into the proscribed analytical stream. As the loaded sample tray rotates, a metal probe dips into the sample cup and aspirates sample for a preset time, rises from the sample cup and aspirates air for approximately one second and goes into a reagent water-filled wash receptacle, where reagent water is aspirated. After another preset interval, the probe rises from the wash receptacle, aspirates air and moves into the next sample cup. The sampler moves at a rate of 40 samples per hour with a sample to wash solution ratio of 9:1.
- 3.42 Sensitivity – The capability of a test method or instrument to discriminate between measurement responses representing different levels (concentrations) of a variable of interest.
- 3.43 Shall – Denotes a requirement that is mandatory whenever the criterion for conformance with the specification requires that there be no deviation. (ANSI)

- 3.44 Should – Denotes a guideline or recommendation whenever noncompliance with the specification is permissible. (ANSI)
- 3.45 Standard Reference Material (SRM) – Material which has been certified for specific analytes by a variety of analytical techniques and/or by numerous laboratories using similar analytical techniques. These may consist of pure chemicals, buffers, or compositional standards. The materials are used as an indication of the accuracy of a specific analytical technique. Also referred to as CRM.

4 INTERFERENCES

- 4.1 Suspended matter in the sample will restrict flow through the apparatus. All samples must be filtered See Section 8.
- 4.2 Concentrations of sulfide, iron, copper or other metals above several milligrams per liter lower reduction efficiency, yielding inaccurate concentrations for those samples and, also, subsequent analyses. Frequent checks of column efficiency and re-analyses of affected samples are necessary.

5 SAFETY

- 5.1 Safety precautions must be taken when handling reagents, samples and equipment in the laboratory. Protective clothing including lab coats, safety glasses and enclosed shoes must be worn. In certain situations, it will be necessary to also use gloves and/or a face shield. If solutions come in contact with eyes, flush with water continuously for 15 minutes. If solutions come in contact with skin, wash thoroughly with soap and water. Contact Solomons Rescue Squad (911) if emergency treatment is needed and also inform the CBL Associate Director of Administration and Facilities Maintenance of the incident. Contact the CBL Associate Director of Administration and Facilities Maintenance if additional treatment is required.
- 5.2 The toxicity or carcinogenicity of each reagent used in this procedure may not have been fully established. Each chemical should be regarded as a potential health hazard and exposure should be as low as reasonably achievable. Cautions are included for known hazardous materials and procedures.
- 5.3 Do not wear jewelry when troubleshooting electrical components. Even low voltage points are dangerous and can injure if allowed to short circuit.
- 5.4 The following hazard classifications are listed for the chemicals used in this procedure. Detailed information is provided on Material Safety Data Sheets (MSDS).

Table 1

Chemical	Health Hazard	Fire Hazard	Instability Hazard	Specific Hazard	
Sodium Hydroxide	3	0	1	ALK, COR	
Copper Sulfate	2	0	0		
Ammonium Chloride	2	0	2		
Sulfanilamide	1	1	0		
N-1-naphthylethylenediamine dihydrochloride	1	0	0		
Brij-35	0	0	0		
Phosphoric Acid	3	0	1	ACID	
Hydrochloric Acid	3	0	2	ACID, COR	
Cadmium	3	0	0		
Potassium nitrate	1	0	0	OXY	
Sodium nitrite	2	0	1	OXY	
Chloroform	3	0	0		

On a scale of 0 to 4, the substance is rated on four hazard categories: health, flammability, reactivity, and contact. (0 is non-hazardous and 4 is extremely hazardous)
HAZARD RATING

Health Hazard - Blue: 4 – deadly, 3 – extreme danger, 2 – hazardous, 1 – slightly hazardous, 0 – normal material

Fire Hazard - Red: Flash Points: 4 – below 73° F, 3 – below 100° F, 2 – below 200° F,

1 – above 200° F, 0 – will not burn

Instability Hazard - Yellow: 4 – may detonate, 3 – Shock and heat may detonate, 2 – violent chemical change, 1 – unstable is heated, 0 - stable

Specific Hazard - White: Acid = ACID, Alkali = ALK, Corrosive = COR, Oxidizer = OXY

6 EQUIPMENT AND SUPPLIES

6.1 Technicon Bran & Luebbe AutoAnalyzer II sampler (now owned by Seal Analytical), proportioning pump, manifold and colorimeter capable of analyzing for nitrate plus nitrite are used in this laboratory. A PMC Industries Flat Bed Linear recorder is used to record electronic output from the colorimeter.

6.2 Freezer, capable of maintaining $-20 \pm 5^{\circ}$ C.

6.3 Lab ware – All reusable lab ware (glass, Teflon, plastic, etc) should be sufficiently clean for the task objectives. This laboratory cleans all lab ware related to this method with a 10% HCl (v/v) acid rinse.

7 REAGENTS AND STANDARDS

7.1 Purity of Water – Unless otherwise indicated, references to water shall be understood to mean reagent water conforming to Specification D 1193, Type I. Freshly prepared water should be used for making the standards intended for calibration. The detection limits of this method will be limited by the purity of the water and reagents used to make the standards.

7.2 Purity of Reagents – Reagent grade chemicals shall be used in all tests. Unless otherwise indicated, it is intended that all reagents shall conform to specifications of the Committee on Analytical Reagents of the American Chemical Society, where such specifications are available. Other grades may be used, provided it is first ascertained that the reagent is of sufficiently high purity to permit its use without compromising the accuracy of the determination.

7.3 Alkaline Water –

Sodium hydroxide (NaOH, pellets)	0.20±0.02 g
Reagent water	up to 1000 mL

Add 0.20 g of sodium hydroxide pellets to 1000 mL of reagent water.

Write name of preparer, preparation date, reagent manufacturer, manufacturer lot number in the Analytical Reagent log book. The reagent is stable for six months.

7.4 Copper Sulfate Reagent, 2% –

Copper sulfate ($\text{CuSO}_4 \cdot 5\text{H}_2\text{O}$)	2 g
Reagent water	up to 100 ml

In a 100 mL volumetric flask, dissolve 2 g of copper sulfate in ~80 mL of reagent water. Dilute to 100 mL with reagent water. Write name of

preparer, preparation date, reagent manufacturer, manufacturer lot number in the Analytical Reagent log book. The reagent is stable for six months.

7.5 Ammonium Chloride Reagent –

Ammonium Chloride (NH ₄ Cl)	10 g
Reagent water	up to 1000 mL
Copper Sulfate Reagent, 2%	6 drops
Sodium Hydroxide	2 pellets

In a 1000 ml volumetric flask, dissolve 10 g of concentrated ammonium chloride to ~800 ml of Reagent Water. Dilute to 1000 mL with Reagent Water. Attain a pH balance of 8.5. Add 6 drops of Copper Sulfate Reagent, 2% and 2 pellets NaOH. Write name of preparer, preparation date, reagent manufacturer, manufacturer lot number in the Analytical Reagent log book. The reagent is stable for six months.

7.6 Color Reagent –

Sulfanilamide (C ₆ H ₈ N ₂ O ₂ S)	10 g
Phosphoric Acid (H ₃ PO ₄), concentrated (80%)	10000 mL
N-1-naphthylethylenediamine dihydrochloride (C ₁₂ H ₁₄ N ₂ ·2HCl)	0.5 g
Reagent water	up to 1000 mL
Brij-35, 30%	1 mL

In a 1000 mL volumetric flask, add 100 mL concentrated phosphoric acid and 10 g of sulfanilamide to ~500 mL reagent water. . Add 0.5 g of N-1-naphthylethylenediamine dihydrochloride and dissolve. Dilute to 1000 ml with reagent water and add 5 mL of 30% Brij-35. Write name of preparer, preparation date, reagent manufacturers, manufacturers' lot numbers in the Analytical Reagent log book. Make fresh every 3 months. Store at 4°C.

7.7 Nitrate Stock Standard, 5000 µM –

Potassium nitrate (KNO ₃), primary standard grade, dried at 45°C	0.253 g
Reagent water	up to 500 mL

In a 500 mL volumetric flask, dissolve 0.253 g of potassium nitrate in ~400 mL of reagent water. Dilute to 500 mL with reagent water (1 mL contains 5 µmoles N). Write name of preparer, preparation date, standard manufacturer, manufacturer lot number in the Analytical Standard log book. Make fresh every 6 months or when < 20% remains in bottle.

7.8 Secondary Nitrate Standard –

Stock Nitrate Standard	0.80 mL
Reagent water	up to 100 mL

In a volumetric flask, dilute 0.80 mL of Stock Nitrate Standard to 100 mL with reagent water to yield a concentration of 40 µM NO₃ –N/L (0.56 mg N/L). Write name of preparer, preparation date, standard manufacturer, manufacturer lot number in the Analytical Standard log book. Make fresh every 4 weeks.

7.9 Working Nitrate Standard – Dilute 1, 2.5, 5, 7.5 and 10 mL of Secondary Standard to 100 mL with reagent water to yield concentrations

of 0.4 $\mu\text{M N}$ (0.0056 mg N/L), 1.0 $\mu\text{M N}$ (0.014 mg N/L), 2.0 $\mu\text{M N}$ (0.028 mg N/L), 3.0 $\mu\text{M N}$ (0.042 mg N/L) and 4.0 $\mu\text{M N}$ (.056 mg N/L). Write name of preparer, preparation date, standard manufacturer, manufacturer lot number in the Analytical Standard log book. Make fresh every 4 weeks.

7.10 Stock Nitrite Standard –

Sodium nitrite (NaNO_2), primary standard grade, dried at 45°C

	0.1725 g
Reagent water	up to 500 mL

In a 500 mL volumetric flask, dissolve 0.1725 g of sodium nitrite in ~400 mL of reagent water. Dilute to 500 mL with reagent water (1 mL contains 5 $\mu\text{moles N}$). Add 1 mL of chloroform as a preservative. Write name of preparer, preparation date, standard manufacturer, manufacturer lot number in the Analytical Standard log book. Make fresh every 6 months or when < 20% remains in bottle.

7.11 Secondary Nitrite Standard –

Stock Nitrite Standard	0.70 mL
Reagent water	up to 100 mL

In a volumetric flask, dilute 0.70 mL of Stock Nitrite Standard to 100 mL with reagent water to yield a concentration of 35 $\mu\text{M NO}_2\text{-N/L}$ (0.49 mg N/L). Write name of preparer, preparation date, standard manufacturer, manufacturer lot number in the Analytical Standard log book. Make fresh every 4 weeks.

8 SAMPLE COLLECTION, PRESERVATION, AND STORAGE

8.1 Water collected for NO_3+NO_2 should be filtered through a Whatman GF/F glass fiber filter (nominal pore size 0.7 μm), or equivalent.

8.2 Water collected for NO_3+NO_2 should be frozen at $\leq -20^\circ\text{C}$. The AutoAnalyzer vial container (sample cups) should be clean and sample rinsed.

8.3 Frozen NO_3+NO_2 samples may be stored up to 28 days. It has been shown that frozen QCS samples up to a year old still fall well within the control limits.

8.4 NO_3+NO_2 samples may be refrigerated at 4° C for no longer than one day.

9 QUALITY CONTROL

9.1 The laboratory is required to operate a formal quality control (QC) program.

The minimum requirements of this program consist of an initial demonstration of laboratory capability and the continued analysis of laboratory instrument blanks and calibration standard material, analyzed as samples, as a continuing check on performance. The laboratory is required to maintain performance records that define the quality of data generated.

9.2 Initial Demonstration of Capability

- 9.2.1 The initial demonstration of capability (iDOC) – is used to characterize instrument performance (MDLs) and laboratory performance (analysis of QC samples) prior to the analyses conducted by this procedure.
- 9.2.2 Linear Dynamic Range – LDR (Linear Calibration Range) should be established for NO_3+NO_2 using appropriate calibration curve of a blank and five standards.
- 9.2.3 Quality Control Sample (QCS/SRM) – When using this procedure, a quality control sample is required to be analyzed at the beginning and end of the run, to verify data quality and acceptable instrument performance. If the determined concentrations are not within $\pm 3s$ of the certified values, performance of the determinative step of the method is unacceptable. The source of the problem must be identified and corrected before either proceeding with the initial determination of MDLs or continuing with analyses.
- 9.2.4 Method Detection Limits (MDLs) – MDLs should be established for NO_3+NO_2 using a low level natural water sample, typically three to five times higher than the estimated MDL. To determine the MDL values, analyze seven replicate aliquots of water. Perform all calculations defined in the procedure (Section 13) and report the concentration values in the appropriate units. Calculate the MDL as follows:

$$\text{MDL} = St_{(n-1,1-\alpha=0.99)}$$

Where,

S = Standard deviation of the replicate analyses.

n=number of replicates

$t_{(n-1,1-\alpha=0.99)}$ = Student's *t* value for the 99% confidence level with n-1 degrees of freedom ($t=3.14$ for 7 replicates.)

MDLs should be determined annually, whenever there is a significant change in instrumental response or a significant change in instrument configuration

9.3 Assessing Laboratory Performance

- 9.3.1 Laboratory Reagent Blank (LRB) – The laboratory must analyze at least one LRB with each batch of samples. The LRB consists of reagent water treated the same as the samples. An amount of analyte above the MDL found in LRB indicates possible reagent or laboratory environment contamination. LRB data are used to assess and correct contamination from the laboratory environment.
- 9.3.2 Quality Control Sample (QCS)/ Standard Reference Material (SRM) – When using this procedure, a quality control sample is required to be analyzed at the beginning of the run and end of the run, to verify data quality and acceptable instrument performance. If the

determined concentrations are not within $\pm 3s$ of the certified values, performance of the determinative step of the method is unacceptable. The source of the problem must be identified and corrected before either proceeding with the initial determination of MDLs or continuing with the analyses. The results of these QCS/SRM samples shall be used to determine batch acceptance.

- 9.3.3 The QCS are obtained from a source external to the laboratory and different from the source of calibration standards.
- 9.3.4 Control Charts – The Accuracy Control Chart for QCS/SRM samples and reagent blanks is constructed from the average and standard deviation of the 20 most recent QCS/SRM measurements. (Reagent blanks in cadmium segmented flow method are baseline blanks. Since the baseline is subtracted from each peak, it is not appropriate to chart these reagent blanks.) The accuracy chart includes upper and lower warning levels ($WL=\pm 2s$) and upper and lower control levels ($CL=\pm 3s$). These values are derived from stated values of the QCS/SRM. The standard deviation (s) is specified relative to statistical confidence levels of 95% for WLs and 99% for CLs. Enter QCS/SRM results on the chart each time the sample is analyzed.
- 9.3.5 Calibration Verification Initial and Continuing (ICV/CCV)– Immediately following calibration (ICV) and following every 18-23 samples (CCV), two calibration verifications of $4.0 \mu\text{M NO}_3$ (0.056 mg N/L) are analyzed to assess instrument performance. The CCVs are made from the same material as calibration standards (KNO_3), and are to be within $TV \pm 3s$. Failure to meet the criteria requires correcting the problem, including reanalysis of any affected samples. If not enough sample exists, the data must be qualified if reported. See Appendix 1 for additional CCVs.
- 9.3.6 Reduction Efficiency Verification (REV) – The REVs are made from NaNO_2 , $35 \mu\text{M NO}_2$ (0.49 mg N/L) and are to be within the expected value $\pm 3s$ of the equivalent CCV, $35 \mu\text{M NO}_3$ (0.49 mg N/L). Failure to meet the criteria requires correcting the problem.

9.4 Assessing Analyte Recovery - Percent Recovery

- 9.4.1 Analyte recovery is assessed through percent recoveries of laboratory spikes of samples.
- 9.4.2 Percent Recovery = (Actual/Expected) x 100

9.5 Assessing Analyte Precision – Relative Percent Difference (RPD)

- 9.5.1 Analyte replication is assessed through duplicate analyses of samples – Relative Percent Difference.
- 9.5.2 $RPD = (\text{Laboratory Duplicate Result 1} - \text{Laboratory Duplicate Result 2}) / [(\text{Laboratory Duplicate Result 1} + \text{Laboratory Duplicate Result 2}) / 2] \times 100$

9.6 Corrective Actions for Out of Control Data

- 9.6.1 Control limit – If one measurement exceeds Accuracy Control Chart CL, repeat the analysis immediately. If the repeat measurement is within the CL, continue analyses; if it exceeds the CL, discontinue analyses and correct the problem.
- 9.6.2 Warning limit – If two out of three successive points exceed Accuracy Control Chart WL, analyze another sample. If the next point is within WL, continue analyses; if the next point exceeds the WL, evaluate potential bias and correct the problem.
- 9.6.3 Trending – If seven successive Accuracy Control Chart measurements are on the same side of the central line, discontinue analyses and correct the problem.
- 9.6.4 When external QCS samples are out of control, correct the problem. Reanalyze the samples analyzed between the last in-control measurement and the out-of-control one.
- 9.6.5 When external CCV samples are out of control, correct the problem. Reanalyze the samples analyzed between the last in-control measurement and the out-of-control one.

9.7 General Operation - To assure optimal operation and analytical results, the Reagent Blank and CCV are tracked daily in the raw data file, copied to Reagent Blank and CCV Control Charts.

Table 2

QC Indicator	Acceptance/ Action Limits	Action	Frequency (Batch)
Correlation Coefficient	≥ 0.995	If <0.995, evaluate data points of the calibration curve. If any data point is outside established limits, reject as outlier.	1 per batch if acceptable.
Quality Control Sample (QCS)/ Certified Reference Material (CRM)	± 10%	If QCS value is outside ± 10% of the target value reject the run, correct the problem and rerun samples.	Beginning of run and at end of run.
Initial Calibration Verification (ICV)	± 10%	Recalibrate if outside acceptance limits.	Beginning of run following standard curve.
Continuing Calibration Verification (CCV)	± 10%	If outside 10%, correct the problem. Rerun all samples following the last in-control CCV.	After every 18-23 samples.

Method Blank/Laboratory Reagent Blank (LRB)	≤ Method Quantitation Limit	If the LRB exceeds the quantitation limit, results are suspect. Rerun the LRB. If the concentration still exceeds the quantitation limit, reject or qualify the data, or raise the quantitation limit.	Following the ICV and after every 18-23 samples following the CCV.
Laboratory Fortified Sample Matrix Spike	± 10%	If the recovery of any analyte falls outside the designated acceptance limits and the QCS is in control, the recovery problem is judged matrix induced. Repeat the LFM and if the sample results are again outside the acceptable recovery range, the sample should be reported with a “matrix induced bias” qualifier.	1/10 (spike OR duplicate)
Laboratory Duplicate	± 10%	If the RPD fails to meet the acceptance limits, the samples should be reanalyzed. If the RPD again fails to meet the acceptance limits, the sample must be reported with a qualifier identifying the sample analysis result as not having acceptable RPD for duplicate analysis.	1/10 (spike OR duplicate)

10 CALIBRATION AND STANDARDIZATION

- 10.1 Calibration – Daily calibration must be performed before sample analysis may begin. Five point calibrations are used with the Technicon Bran & Luebbe AutoAnalyzer II.
- 10.2 Working Nitrate Standards – Dilute 1, 2.5, 5, 7.5 and 10 mL of Secondary Standard to 100 mL with reagent water to yield concentrations of 0.4 μM N (0.0056 mg N/L), 1.0 μM N (0.014 mg N/L), 2.0 μM N (0.028 mg N/L), 3.0 μM N (0.042 mg N/L) and 4.0 μM N (0.056 mg N/L).
- 10.3 Prepare standard curve by plotting response on recorder of each and every standard processed through the manifold against NO₃ –N/L concentration in standards.

Compute sample $\text{NO}_3 + \text{NO}_2$ -N/L concentration by comparing sample response on recorder with standard curve. If NO_3 -N/L concentration is required, subtract NO_2 -N/L concentration from $\text{NO}_3 + \text{NO}_2$ -N/L concentration. The coefficient of determination (Pearson's r value) for the calibration curve as well as the calculated concentration of each calibrator is reviewed. The calculated value of each calibrator must be within ten percent of the expected value. The coefficient of determination (Pearson's r value) for the calibration curve must be greater than 0.995.

11 PROCEDURE – NEW REDUCTION COLUMN PREPARATION

- 11.1 Prepare Copper-Cadmium Column – Use good quality cadmium filings of 25-60 mesh size.
- 11.2 Clean 10 g of cadmium with 20 mL of acetone. Rinse twice with 20 mL of reagent water. Next, clean cadmium with 50 mL of 1 N Hydrochloric Acid for 1 minute. Cadmium turns silver in color. Decant Hydrochloric Acid and wash the cadmium with another 50 mL of 1 N Hydrochloric Acid for 1 minute.
- 11.3 Decant 1 N Hydrochloric Acid and wash the cadmium several times with reagent water.
- 11.4 Decant reagent water and add 20 mL of 2% (w/v) Copper Sulfate ($\text{CuSO}_4 \cdot 5\text{H}_2\text{O}$). Wash the cadmium until no blue color remains in the solution.
- 11.5 Decant Copper Sulfate solution and add another 20 mL of 2% (w/v) Copper Sulfate ($\text{CuSO}_4 \cdot 5\text{H}_2\text{O}$). Wash the cadmium until no blue color remains in the solution. The cadmium will be dark brown in color.
- 11.6 Decant Copper Sulfate solution and wash thoroughly (~10 times) with reagent water.
- 11.7 Set up Manifold, following general procedure of manufacturer in the following prescribed order.
- 11.8 Insert a glass wool plug at the outlet end of the column. Fill the reductor column tubing (22 cm length of 0.110-inch ID Tygon tubing) with reagent water and transfer the prepared cadmium granules to the column using a Pasteur pipette or some other method that prevents contact of cadmium granules with air. Do not allow any air bubbles to be trapped in column. Pack entire column uniformly with filings such that, visually, the packed filings have separation gaps $\leq \sim 1\text{mm}$.
- 11.9 Ammonium Chloride Reagent initiates analytical sample stream from 1.20 mL/min Yellow/Yellow pump tube.
- 11.10 Air is injected from 0.32 mL/min Black/Black pump tube.
- 11.11 Sample is added from 0.32 mL/min Black/Black pump tube.
- 11.12 Mixing occurs in five turn coil.
- 11.13 Air bubbles are de-bubbled from analytical sample stream using 0.60 mL/min Red/Red pump tube.
- 11.14 De-bubbled analytical sample stream passes through 22 cm reductor column.
- 11.15 Air is injected from 0.32 mL/min Black/Black pump tube.

- 11.16 Color Reagent is added from 0.32 mL/min Black/Black pump tube.
- 11.17 Mixing occurs in twenty-two turn coil.
- 11.18 Analytical sample stream enters 1.5 mm ID, 50 mm long Flow Cell pulled by 0.80 mL/min waste line. Bubbles and remainder of sample stream exit by gravity.
- 11.19 Color of analytical sample stream is quantitatively read at 550 nm by Colorimeter with 199-B021-01 Phototube, electronic output recorded on strip chart of Recorder.
- 11.20 Attach pump tubes to end rails of Proportioning Pump. Put platen on Proportioning Pump. With reagent water running through the sample line and Ammonium Chloride Reagent running through its designated line, attach the column. Make sure there are no air bubbles in the valve and attach the column to the intake side of the valve first. Open the valve to allow Ammonium Chloride Reagent stream to flow through the column. Allow reagent water to run through the Color Reagent line.
- 11.21 Turn on Colorimeter and Recorder.
- 11.22 Check for good flow characteristics (good bubble pattern) after insertion of air bubbles beyond the column. If the column is packed too tightly, an inconsistent flow pattern will result. Allow Ammonium Chloride Reagent to flow through Column, manifold and Colorimeter for one hour.
- 11.23 At conclusion of that hour, condition the column with approximately 100 mg N/L (KNO_3) for 5 minutes, followed by approximately 100 mg N/L (NaNO_2) for 5 minutes. Turn Baseline Knob on Colorimeter to obtain 0 deflection on Recorder.
- 11.24 Attach Color Reagent line to Color Reagent. At Colorimeter Standard Calibration setting of 1.00, note deflection on Recorder. Reject Color Reagent if deflection is more than 8 out of total 100 chart units. Turn Baseline Knob on Colorimeter to obtain 0 deflection on Recorder.
- 11.25 At Colorimeter Standard Calibration setting of 1.00, analyze Secondary Nitrate Standard ($35 \mu\text{M NO}_3\text{-N/L}$ (0.49 mg N/L)) and Secondary Nitrite Standard ($35 \mu\text{M NO}_2\text{-N/L}$ (0.49 mg N/L)). If peak height of Secondary Nitrate Standard is <90% of peak height of Secondary Nitrite Standard, prepare new cadmium reduction column.
- 11.26 Set Colorimeter Standard Calibration setting at 9.00. Analyze Working Nitrate Standards. Prepare standard curve by plotting response on recorder of standards processed through the manifold against $\text{NO}_3\text{-N/L}$ concentration in standards.
- 11.27 Analyze samples. Compute sample $\text{NO}_3\text{-N/L}$ concentration by comparing sample response on Recorder with standard curve.
- 11.28 At the end of the run, at Colorimeter Standard Calibration setting 1.00, analyze Secondary Nitrate Standard ($35 \mu\text{M NO}_3\text{-N/L}$ (0.49 mg N/L)) and Secondary Nitrite Standard ($35 \mu\text{M NO}_2\text{-N/L}$ (0.49 mg N/L)). If peak height of Secondary Nitrate Standard is <90% of peak height of Secondary Nitrite Standard, reject all sample concentrations and prepare a new cadmium reduction column.

- 11.29 Allow reagent water to flow through the sample line for 10 minutes. Close the valve to the column, diverting flow. Allow reagent water to flow through sample, Ammonium Chloride and Color Reagent lines for one minute. Turn Proportioning Pump switch to fast pump for its allotted time.
- 11.30 Turn off Sampler, Colorimeter and Recorder. Release and remove Proportioning Pump platen. Release pump tube holders from end rails.

12 PROCEDURE – DAILY OPERATION

- 12.1 Attach pump tubes to end rails of Proportioning Pump. Put platen on Proportioning Pump. Allow reagent water to run through the sample line, Ammonium Chloride Reagent to run through its line and reagent water to run through the Color Reagent line. Check for good flow characteristics (good bubble pattern). Open the valve to allow Ammonium Chloride Reagent stream to flow through the column.
- 12.2 Turn on Colorimeter and Recorder. Set Colorimeter Standard Calibration setting to 1.00. Let liquid pump through the column, Manifold and Colorimeter for 45 minutes.
- 12.3 At the conclusion of the 45 minutes, turn Baseline Knob on Colorimeter to obtain 0 deflection on Recorder.
- 12.4 Attach Color Reagent line to the Color Reagent. At a Colorimeter Standard Calibration setting of 1.00, note deflection on the Recorder. Reject Color Reagent if deflection is more than 8 out of total 100 chart units. Turn Baseline Knob on the Colorimeter to obtain 0 deflection on Recorder.
- 12.5 At Colorimeter Standard Calibration setting 1.00, analyze Secondary Nitrate Standard (35 μM NO_3^- /L (0.49 mg N/L)) and Secondary Nitrite Standard (35 μM NO_2^- /L (0.49 mg N/L)). If the peak height of Secondary Nitrate Standard is <90% of the peak height of Secondary Nitrite Standard, prepare a new cadmium reduction column.
- 12.6 Analyze CRM sample by dilution in order for the concentration to be in the middle of the calibration curve.
- 12.7 Set Colorimeter Standard Calibration setting at 9.00. Analyze Working Nitrate Standards. Prepare standard curve by plotting response on recorder of standards processed through the manifold against NO_3^- /L concentration in standards in Excel.
- 12.8 Analyze samples. Compute sample NO_3^- /L concentration by comparing sample response on Recorder with standard curve in Excel.
- 12.9 At the end of the run, at a Colorimeter Standard Calibration setting of 1.00, analyze Secondary Nitrate Standard (35 μM NO_3^- /L (0.49 mg N/L)) and Secondary Nitrite Standard (35 μM NO_2^- /L (0.49 mg N/L)). If the peak height of Secondary Nitrate Standard is <90% of the peak height of Secondary Nitrite Standard, reject all sample concentrations and prepare a new cadmium reduction column.
- 12.10 Analyze CRM sample by dilution in order for the concentration to be in the middle of the calibration curve.
- 12.11 Allow reagent water to flow through the sample line for 10 minutes. Close the valve to the column, diverting flow. Allow reagent water to flow through

- the sample, Ammonium Chloride and Color Reagent lines for one minute.
Turn Proportioning Pump switch to fast pump for its allotted time.
- 12.12 Turn off Sampler, Colorimeter and Recorder. Release and remove Proportioning Pump platen. Release pump tube holders from end rails.

13 DATA ANALYSIS AND CALCULATIONS

- 13.1 Upon completion of all analysis, results are saved to a Microsoft Excel daily report file. The file is named by the run date. The daily report file for analytical batch of January 1, 2015 would be named 010115AAIINO23. Peak heights for each sample on chart recorder paper are noted and entered into the report file. Compute sample NO_3 -N/L concentration by comparing sample response on chart recorder paper with standard curve in Excel. The analyst examines each row of data. Results are eliminated that are outside the limits of the calibration range.

14 REFERENCES

- 14.1 Technicon Industrial Method No. 158-71 W/A Tentative. 1977. Technicon Industrial Systems. Tarrytown, New York, 10591.
- 14.2 USEPA. 1979. Method No. 353.2 *in* Methods for chemical analysis of water and wastes. United States Environmental Protection Agency, Office of Research and Development. Cincinnati, Ohio. Report No. EPA-600/4-79-020 March 1979. 460pp.

Range	Pump Tubes	umoles NO3/L	mg N/L	ml 40uM KNO3 std/100ml	CCV
Low		0	0	Reagent Water	0.056 mg NO23-N/L
	Blk/Blk sample	0.4	0.0056	1.0	
	Yel/Yel NH4Cl	1	0.014	2.5	
	Std Cal. 9.0	2	0.028	5.0	
		3	0.042	7.5	
High		4	0.056	10.0	0.21 mg NO23-N/L
	Orn/Grn sample	0	0	Reagent Water	
	Yel/Blu NH4Cl	2	0.028	5.0	
	Std Cal. 9.0	3	0.042	7.5	
		4	0.056	10.0	
		7	0.098	0.14 Primary KNO3	
		10	0.14	0.2 Primary KNO3	
	15	0.21	0.3 Primary KNO3		
XHigh Dilution Loop				ml Primary KNO3 Std/100ml	2.8 mg NO23-N/L
	Orn/Wht sample	0	0	Reagent Water	
	Yel/Yel NH4Cl	35	0.49	0.7	
	Yel/Yel DI	50	0.7	1.0	
	Orn/Yel resample	75	1.05	1.5	
	Std Cal 3.0	100	1.4	2.0	
		150	2.1	3.0	
	200	2.8	4.0		

Appendix 1

UNIVERSITY OF MARYLAND CENTER FOR ENVIRONMENTAL SCIENCE
CHESAPEAKE BIOLOGICAL LABORATORY
NUTRIENT ANALYTICAL SERVICES LABORATORY
146 Williams St., Solomons MD 20688
<http://nasl.cbl.umces.edu/>

**Standard Operating Procedure for
Determination of Dissolved Inorganic Nitrate plus Nitrite (NO₃+NO₂) in
Fresh/Estuarine/Coastal Waters Using Enzyme Catalyzed Reduction
(References EPA 353.2, Standard Methods #4500-N C, 4500-NO₃ F)**

**Revision 2017-1
Replaces Revision 2015
Effective April 26, 2017**

Revised by: _____ Date: _____

Reviewed by: _____ Date: _____

Laboratory Supervisor: _____ Date: _____

Changes affecting Revision 2015

Section 1.2: Inserted If more than seven replicates are used to determine the MDL, refer to the Student's *t* test table for the appropriate n-1 value.

Section 1.7: Used references instead of conforms

Section 3.4: Changed the lowest standard for analytical range to 0.028

Section 3.5: Deleted preparation batch definition

Section 3.23: Deleted Instrument Detection Limit

Section 3.24: Changed blank matrix to matrix blank

Entire Document: Changed deionized water to reagent water

Section 3.26: Added This is also referred to as MDL.

Section 3.27: Added This is also referred to as the Quantitation Limit

Section 3.36: Added Also referred to as CRM

Section 3.43: Added Also referred to as CRM

Section 5.1 Changed the word should to must, Changed CBL Business Manager to the CBL Associate Director of Administration and Facilities Maintenance

Section 5.4: Updated Chemical Safety Table (Table 1)

Section 6.1: Added Windows Operating System

Section 7.4: Changed EDTA concentration to 0.25M

Section 7.7: Changed Sulfanilamide concentration to be made in 500 ml instead of 1L

Section 7.8: Changed N-1-Nap concentration to be made in 500mL instead of 1L

Section 7.9: Changed KNO₃ standard to be made in 500mL instead of 1L

Section 7.10: Changed NaNO₂ standard to be made in 500 ml instead of 1L

Section 7.11: Changed secondary NaNO₂ concentration to 0.49 mg/L

Section 7.12: Changed the Aquakem Cleaning Solution to be made with 55mL instead of 75mL

Section 8.1: Added ≤ sign for freezer temp

Section 8.2: Added the words sample cups

Section 9.2.1: Changed the initial demonstration of capability acronym to iDOC

Section 9.2.3: Changed QCS determinations from 10% to 3s

Section 9.2.4: Deleted from MDL description the change of operator or a new matrix is encountered, changed ambient water to natural water

Section 9.3.1: Deleted LRB above the MDL requires that the source of the problem must be identified and corrected before proceeding with analysis

Section 9.3.4: Added the words reagent blanks, deleted Set up an accuracy chart by using percent recovery since the concentration of the QCS/SRM varies

Section 9.3.5: Added ICV information to the CCV, Added See Appendix 1 for additional CCVs.

Section 9.3.6: Changed TV to the expected value

Section 9.3.7: Removed reagent blank description

Section 9.4: Changed % to read Percent

Section 9.7: Added Table 2

Section 10.1: Updated the calibrators used

Section 10.2: Added the coefficient of determination (Pearson's *r* value) for the calibration curve as well as the calculated concentration of each calibrator is reviewed.

The calculated value of each calibrator must be within ten percent of the expected value. The coefficient of determination (Pearson's r value) for the calibration curve must be greater than 0.995.

Section 11: Added step by step descriptions for using Aquakem software

Section 13: Removed Method Performance

Appendix 1: Added Appendix 1

Determination of Dissolved Inorganic Nitrate plus Nitrite (NO₃+NO₂) in Fresh/Estuarine/Coastal Waters Using Enzyme Catalyzed Reduction

1. SCOPE and APPLICATION

- 1.1 Enzyme catalyzed reduction is used to quantitatively reduce dissolved nitrate to nitrite which is then measured by colorimetric quantitative analysis of a highly colored azo dye. The method is used to analyze all ranges of salinity.
- 1.2 A Method Detection Limit (MDL) of 0.005 mg NO₃+NO₂-N/L was determined using the Student's *t* value (3.14, n=7) times the standard deviation of a minimum of seven replicates. If more than seven replicates are used to determine the MDL, refer to the Student's *t* test table for the appropriate n-1 value.
- 1.3 The Quantitation Limit for NO₃+NO₂ was set at 0.015 mg NO₃+NO₂-N/L.
- 1.4 The method is suitable NO₃+NO₂ concentrations 0.028 to 5.6 mg NO₃+NO₂-N/L.
- 1.5 This procedure should be used by analysts experienced in the theory and application of aqueous inorganic analysis. A three month training period with an analyst experienced in the analysis of nitrate plus nitrite in aqueous samples by enzyme catalyzed reduction is required.
- 1.6 This method can be used for all programs that require analysis of dissolved inorganic nitrate plus nitrite.
- 1.7 A portion of this procedure references Standard Methods #4500-N C, 4500-NO₃ F and EPA Method 353.2 (1979). Method for Nitrate Reductase Nitrate-Nitrogen Analysis (ATP Case No. N07-0003) has been reviewed by the US EPA and is awaiting final approval. It is now part of the EPA Methods Update Rule 2015 and has been published to the EPA Federal Register Vol. 80 No. 33. It is recommended as an addition of approved methods at 40 CFR Part 136 and currently accepting comments.

2. SUMMARY

2.1 Filtered samples are mixed with Nitrate Reductase (AtNaR2, commercially available, is a recombinantly produced form of eukaryotic Nitrate Reductase using a modified gene from the plant *Arabidopsis thaliana*. The enzyme AtNaR2 is produced in *Pichia pastoris* and purified from extracts of the yeast.) and NADH (β -Nicotinamide adenine dinucleotide reduced form disodium salt). The nitrite, both that which was reduced from nitrate and nitrite that was originally present, is then determined by diazotizing with sulfanilamide and coupling with N-1-naphthylethylenediamine dihydrochloride to form a colored azo dye. Filtered samples with concentrations found to be below the method

detection limit are analyzed via cadmium reduction with a Technicon Bran & Luebbe AutoAnalyzer II.

3. DEFINITIONS

- 3.1 Acceptance Criteria – Specified limits placed on characteristics of an item, process, or service defined in a requirement document. (ASQC)
- 3.2 Accuracy – The degree of agreement between an observed value and an accepted reference value. Accuracy includes a combination of random error (precision) and systematic error (bias) components which are due to sampling and analytical operations; a data quality indicator. (QAMS)
- 3.3 Aliquot – A discrete, measured, representative portion of a sample taken for analysis. (EPA QAD Glossary)
- 3.4 Analytical Range – 0.028 to 5.6 mg NO₃+NO₂-N/L. The overall analytical range is comprised of three distinct yet overlapping concentration ranges. A separate calibration is performed for each range. These ranges include 0.028 to 0.28 mg NO₃+NO₂-N/L, 0.07 to 0.70 mg NO₃+NO₂-N/L and 0.56 to 5.6 mg NO₃+NO₂-N/L. Three sub-ranges are utilized so that samples can be analyzed on the most appropriate scale possible.
- 3.5 Batch – Environmental samples, which are prepared and /or analyzed together with the same process and personnel, using the same lot(s) of reagents. An **analytical batch** is composed of prepared environmental samples (extracts, digestates, concentrates) and/or those samples not requiring preparation, which are analyzed together as a group using the same calibration curve or factor. An analytical batch can include samples originating from various environmental matrices and can exceed 20 samples. (NELAC/EPA)
- 3.6 Blank- A sample that has not been exposed to the analyzed sample stream in order to monitor contamination during sampling, transport, storage or analysis. The blank is subjected to the usual analytical and measurement process to establish a zero baseline or background value and is sometimes used to adjust or correct routine analytical results. (ASQC)
- 3.7 Calibrate- To determine, by measurement or comparison with a standard, the correct value of each scale reading on a device. The levels of the applied calibration standard should bracket the range of planned or expected sample measurements. (NELAC)
- 3.8 Calibration – The set of operations which establish, under specified conditions, the relationship between values indicated by a measuring device. The levels of the applied calibration standard should bracket the range of planned or expected sample measurements. (NELAC)
- 3.9 Calibration Blank – A volume of reagent water fortified with the same matrix as the calibration standards, without the analyte added.

- 3.10 Calibration Curve – The graphical relationship between known values, such as concentrations, or a series of calibration standards and their analytical response. (NELAC)
- 3.11 Calibration Method – A defined technical procedure for performing a calibration. (NELAC)
- 3.12 Calibration Standard – A substance or reference material used to calibrate an instrument. (QAMS)
 - 3.12.1 Initial Calibration Standard (STD) – A series of standard solutions used to initially establish instrument calibration responses and develop calibration curves for individual target analytes.
 - 3.12.2 Initial Calibration Verification (ICV) – An individual standard, distinct from the Initial Calibration Standards (STD), analyzed initially, prior to any sample analysis, which verifies acceptability of the calibration curve or previously established calibration curve.
 - 3.12.3 Continuing Calibration Verification (CCV) – An individual standard, distinct from the Initial Calibration Standards (STD), analyzed after every 18-23 field sample analyses.
- 3.13 Certified Reference Material – A reference material one or more of whose property values are certified by a technically valid procedure, accompanied by or traceable to a certificate or other documentation which is issued by a certifying body. (ISO 17025)
- 3.14 Corrective Action – Action taken to eliminate the causes of an existing nonconformity, defect or other undesirable situation in order to prevent recurrence. (ISO 8402)
- 3.15 Deficiency – An unauthorized deviation from acceptable procedures or practices. (ASQC)
- 3.16 Demonstration of Capability – A procedure to establish the ability of the analyst to generate acceptable accuracy. (NELAC)
- 3.17 Detection Limit – The lowest concentration or amount of the target analyte that can be determined to be different from zero by a single measurement at a stated degree of confidence.
- 3.18 Duplicate Analysis – The analyses of measurements of the variable of interest performed identically on two sub samples (aliquots) of the same sample. The results from duplicate analyses are used to evaluate analytical or measurement precision but not the precision of sampling, preservation or storage internal to the laboratory. (EPA-QAD)
- 3.19 External Standard (ES) – A pure analyte (potassium nitrate (KN O₃)) that is measured in an experiment separate from the experiment used to measure the analyte(s) in the sample. The signal observed for a known quantity of the pure external standard is used to calibrate the instrument response for the corresponding analyte(s). The instrument response is used to calculate the concentrations of the analyte(s) in the unknown sample.

- 3.20 Field Duplicates (FD1 and FD2) – Two separate samples collected at the same time and place under identical circumstances and treated exactly the same throughout field and laboratory procedures. Analyses of FD1 and FD2 provide a measure of the precision associated with sample collection, preservation and storage, as well as with laboratory procedures.
- 3.21 Field Reagent Blank (FRB) – A aliquot of reagent water or other blank matrix that is placed in a sample container in the laboratory and treated as a sample in all respects, including shipment to the sampling site, exposure to the sampling site conditions, storage, preservation, and all analytical procedures. The purpose of the FRB is to determine if method analytes or other interferences are present in the field environment.
- 3.22 Holding time – The maximum time that samples may be held prior to analysis and still be considered valid. (40 CFR Part 136) The time elapsed from the time of sampling to the time of extraction or analysis, as appropriate.
- 3.23 Laboratory Duplicates (LD1 and LD2) – Two aliquots of the same sample taken in the laboratory and analyzed separately with identical procedures. Analyses of LD1 and LD2 indicate precision associated with laboratory procedures, but not with sample collection, preservation, or storage procedures.
- 3.24 Laboratory Reagent Blank (LRB) – A matrix blank (i.e., reagent water) that is treated exactly as a sample including exposure to all glassware, equipment, solvents, and reagents that are used with other samples. The LRB is used to determine if method analytes or other interferences are present in the laboratory environment, the reagents, or the instrument.
- 3.25 Laboratory Control Sample (LCS) – A sample matrix, free from the analytes of interest, spiked with verified known amounts of analytes from a source independent of the calibration standard or a material containing known and verified amounts of analytes. The LCS is generally used to establish intra-laboratory or analyst-specific precision and bias or to assess the performance of all or a portion of the measurement system. (NELAC)
- 3.26 Limit of Detection (LOD) – The lowest concentration level that can be determined by a single analysis and with a defined level of confidence to be statistically different from a blank. This is also referred to as MDL. (ACS)
- 3.27 Limit of Quantitation (LOQ) – The minimum levels, concentrations, or quantities of a target variable (target analyte) that can be reported with a specified degree of confidence. The LOQ is set at 3 to 10 times the LOD, depending on the degree of confidence desired. This is also referred to as the Quantitation Limit.

- 3.28 Linear Dynamic Range (LDR) – The absolute quantity over which the instrument response to an analyte is linear. This specification is also referred to as the Linear Calibration Range (LCR).
- 3.29 Material Safety Data Sheets (MSDS) – Written information provided by vendors concerning a chemical’s toxicity, health hazards, physical properties, fire, and reactivity data including storage, spill, and handling precautions.
- 3.30 May – Denotes permitted action, but not required action. (NELAC)
- 3.31 Method Detection Limit (MDL) – The minimum concentration of an analyte that can be identified, measured, and reported with 99% confidence that the analyte concentration is greater than zero (Standard Methods).
- 3.32 Must – Denotes a requirement that must be met. (Random House College Dictionary)
- 3.33 Photometer – measures the absorbance of the solution in the cell in a multicell cuvette. Light passes from the lamp through the condensing lenses to the interference filter. The plane surface of the first condensing lens is coated with a material which reflects heat and infrared light. The filters are mounted on a filter wheel. There are 15 positions for filters. Each filter corresponds to a wavelength of interest. The 540 nm filter is specified by the test definition for nitrate plus nitrite. After passing through the filter the light is converted into a stream of light pulses by a chopper. Then the light is directed via a quartz fiber through a focusing lens and a slit to the beam divider. The beam divider divides the light into two parts. A specified portion is reflected to the reference detector, which monitors the light level fluctuations. The remaining major portion of the light beam goes through the liquid in the cell to the signal detector, which measures the amount of light absorbed.
- 3.34 Precision – The degree to which a set of observations or measurements of the same property, obtained under similar conditions, conform to themselves; a data quality indicator. Precision is usually expressed as standard deviation, variance or range, in either absolute or relative terms. (NELAC)
- 3.35 Preservation – Refrigeration, freezing, and/or reagents added at the time of sample collection (or later) to maintain the chemical and or biological integrity of the sample.
- 3.36 Quality Control Sample (QCS) – A sample of analyte of known and certified concentration. The QCS is obtained from a source external to the laboratory and different from the source of calibration standards. It is used to check laboratory performance with externally prepared test materials. Also referred to as CRM.
- 3.37 Run Cycle – Typically a day of operation – the entire analytical sequence from sampling the first standard to the last sample of the day.

- 3.38 Sample Segment – Bar-coded metal tray that holds up to fourteen four milliliter auto analyzer vials containing samples or standards. The user identifies each vial in the operating software.
- 3.39 Sample Segment Holder – An automated temperature controlled carousel that contains up to six sample segments. This carousel spins in clockwise or counterclockwise manner to move the sample segments into position for analysis. This carousel format allows for continuous processing.
- 3.40 Sensitivity – The capability of a test method or instrument to discriminate between measurement responses representing different levels (concentrations) of a variable of interest.
- 3.41 Shall – Denotes a requirement that is mandatory whenever the criterion for conformance with the specification requires that there be no deviation. (ANSI)
- 3.42 Should – Denotes a guideline or recommendation whenever noncompliance with the specification is permissible. (ANSI)
- 3.43 Standard Reference Material (SRM) – Material which has been certified for specific analytes by a variety of analytical techniques and/or by numerous laboratories using similar analytical techniques. These may consist of pure chemicals, buffers, or compositional standards. The materials are used as an indication of the accuracy of a specific analytical technique. Also referred to as CRM.
- 3.44 Test Definition – A photometric test consisting of a user defined testing sequence, reagent additions, calibration standards, incubations and absorption results.
- 3.45 Test Flow – Functions to define the parameter for reagent and sample dispensing, dilution, incubation and measurement.

4 INTERFERENCES

- 4.1 Suspended matter in the sample will scatter light as it passes through the cuvette to the detector. High blank responses will result. The identified sample will be reanalyzed.
- 4.2 Blemishes in the cuvette, as result of the manufacturing process, will result in high blank responses. The identified sample will be reanalyzed.

5 SAFETY

- 5.1 Safety precautions must be taken when handling reagents, samples and equipment in the laboratory. Protective clothing including lab coats, safety glasses and enclosed shoes must be worn. In certain situations, it will be necessary to also use gloves and/or a face shield. If solutions come in contact with eyes, flush with water continuously for 15 minutes. If solutions come in contact with skin, wash thoroughly with soap and water. Contact Solomons Rescue Squad (911) if emergency treatment is needed and also inform the CBL Associate Director of Administration and Facilities Maintenance of the incident. Contact the CBL

Associate Director of Administration and Facilities Maintenance if additional treatment is required.

- 5.2 The toxicity or carcinogenicity of each reagent used in this procedure may not have been fully established. Each chemical should be regarded as a potential health hazard and exposure should be as low as reasonably achievable. Cautions are included for known hazardous materials and procedures.
- 5.3 Do not wear jewelry when troubleshooting electrical components. Even low voltage points are dangerous and can injure if allowed to short circuit.
- 5.4 The following hazard classifications are listed for the chemicals used in this procedure. Detailed information is provided on Material Safety Data Sheets (MSDS).

Table 1

Chemical	Health Hazard	Fire Hazard	Instability Hazard	Specific Hazard	
Nitrate Reductase (AtNaR2) from <i>Arabidopsis thaliana</i>	0	0	0		
NADH (β -Nicotinamide adenine dinucleotide reduced form disodium salt)	0	0	0		
Potassium hydroxide	3	0	2	4	
Sulfanilamide	1	1	0		
N-1-naphthylethylenediamine dihydrochloride	1	0	0		
Hydrochloric Acid	3	0	2	ACID, COR	
Potassium nitrate	1	0	0	OXY	
Sodium nitrite	2	0	1		
Potassium phosphate	2	0	0		
EDTA (Ethylenediamine tetraacetic acid)	1	0	0		

On a scale of 0 to 4 the substance is rated on four hazard categories: health, flammability, reactivity, and contact. (0 is non-hazardous and 4 is extremely hazardous)

HAZARD RATING

Health Hazard - Blue: 4 – deadly, 3 – extreme danger, 2 – hazardous, 1 – slightly hazardous, 0 – normal material

Fire Hazard - Red: Flash Points: 4 – below 73° F, 3 – below 100° F, 2 – below 200° F, 1 – above 200° F, 0 – will not burn

Instability Hazard - Yellow: 4 – may detonate, 3 – Shock and heat may detonate, 2 – violent chemical change, 1 – unstable is heated, 0 - stable

Specific Hazard - White: Acid = ACID, Alkali = ALK, Corrosive = COR, Oxidizer = OXY

6 EQUIPMENT AND SUPPLIES

- 6.1 Aquakem 250 multi-wavelength automated discrete photometric analyzer.
Aquakem 250 control software operates on a computer running Microsoft Windows NT, XP, or 7 operating system.
- 6.2 Freezer, capable of maintaining $-20 \pm 5^{\circ}$ C.
- 6.3 Lab ware – All reusable lab ware (glass, Teflon, plastic, etc) should be sufficiently clean for the task objectives. This laboratory cleans all lab ware related to this method with a 10% HCl (v/v) acid rinse.

7 REAGENTS AND STANDARDS

- 7.1 Purity of Water – Unless otherwise indicated, references to water shall be understood to mean reagent water conforming to Specification D 1193, Type I. Freshly prepared water should be used for making the standards intended for calibration. The detection limits of this method will be limited by the purity of the water and reagents used to make the standards.
- 7.2 Purity of Reagents – Reagent grade chemicals shall be used in all tests. Unless otherwise indicated, it is intended that all reagents shall conform to specifications of the Committee on Analytical Reagents of the American Chemical Society, where such specifications are available. Other grades may be used, provided it is first ascertained that the reagent is of sufficiently high purity to permit its use without compromising the accuracy of the determination.
- 7.3 Ethylenediamine tetraacetic acid (EDTA, 25 mM) 9.3 g
In a 1 L volumetric flask add approximately 800 mL reagent water.
Dissolve 9.3 g ultrapure EDTA in reagent water and bring to volume.
Write name of preparer, preparation date, reagent manufacturer, manufacturer's lot number in the Analytical Reagent log book. Store the flask at room temperature out of direct sunlight. The reagent is stable for one year.
- 7.4 Phosphate Buffer-

Potassium di-hydrogen phosphate (KH ₂ PO ₄)	1.88 g
Potassium hydroxide (KOH)	0.7 g

EDTA (0.25 M) 5.0 mL

In a 500mL volumetric flask dissolve 1.88 g KH_2PO_4 , 0.7g KOH and 5.0 mL EDTA (0.25M) in approximately 400 mL reagent water. Bring flask to volume. Store the flask at room temperature. Write name of preparer, preparation date, reagent manufacturers, manufacturers' lot numbers in the Analytical Reagent log book. The reagent is stable for six months.

7.5 Nitrate Reductase (AtNaR2)-

Nitrate reductase from *Arabidopsis Thaliana* 3.0 unit vial
Phosphate Buffer 20 mL

Transfer 1mL phosphate buffer to the 3.0 unit vial of AtNaR2 to affect dissolution. Shake several times over a thirty minute period. Transfer this to the 20mL reagent bottle quantitatively with four 1 ml aliquots of the phosphate buffer. Add 15mL of phosphate buffer to the reagent bottle. Shake bottle to complete the reagent preparation. This is enough reagent for approximately 300 analyses. Write name of preparer, preparation date, reagent manufacturers, manufacturers' lot numbers in the Analytical Reagent log book. This reagent is stable for eight hours in the refrigerated reagent compartment of the instrument.

7.6 NADH-

(β -Nicotinamide adenine dinucleotide reduced form disodium salt) 2.4 g vial
Phosphate Buffer 11 mL

Carefully transfer NADH crystals from vial to 20 mL reagent bottle. Place 1 mL phosphate buffer in vial and shake thoroughly. Transfer to reagent bottle. Add 10 mL phosphate buffer to the reagent bottle. Shake to complete reagent preparation. This is enough reagent for approximately 300 analyses. Write name of preparer, preparation date, reagent manufacturers, manufacturers' lot numbers in the Analytical Reagent log book. This reagent is stable for eight hours in the refrigerated reagent compartment of the instrument.

7.7 Sulfaniamide-

Sulfanilamide 5 g
Hydrochloric Acid (concentrated) 150 mL

Add 250 mL reagent water to a 500 mL volumetric flask. Carefully add 150 mL concentrated hydrochloric acid to the flask. Then add 5 g sulfanilamide to the flask. Bring the flask to volume with reagent water. Once dissolution is complete transfer reagent to a brown poly-bottle and store in the refrigerator. Write name of preparer, preparation date, reagent manufacturers, manufacturers' lot numbers in the Analytical Reagent log book. This reagent is stable for six months.

7.8 N-1-naphylethylenediamine dihydrochloride –

N-1-naphylethylenediamine dihydrochloride 0.5 g

Place 0.5 g N-1-naphylethylenediamine dihydrochloride in a 500mL volumetric flask. Bring flask to volume with reagent water. Once dissolution is complete transfer reagent to a brown poly-bottle and store in refrigerator. Write name of preparer, preparation date, reagent

manufacturer, manufacturer lot number in the Analytical Reagent log book. This reagent is stable for six months.

7.9 Nitrate Stock Standard, 5000 μM –

Potassium nitrate (KNO_3), primary standard grade, dried at 45°C
0.253 g

In a 500mL volumetric flask, dissolve 0.253 g of potassium nitrate in approximately 400 mL reagent water. Bring flask to volume with reagent water (1 mL contains 5 $\mu\text{moles N}$). Write name of preparer, preparation date, standard manufacturer, manufacturer lot number in the Analytical Standard log book. Make fresh every 6 months or when <20% remains in bottle.

7.10 Stock Nitrite Standard –

Sodium nitrite (NaNO_2), primary standard grade, dried at 45°C
0.1725 g

In a 500mL volumetric flask, dissolve 0.1725 g of sodium nitrite in approximately 400 mL of reagent water. Dilute to volume with reagent water (1 mL contains 5 $\mu\text{moles N}$). Add 1 mL of chloroform as a preservative. Write name of preparer, preparation date, standard manufacturer, manufacturer lot number in the Analytical Standard log book. Make fresh every 6 months or when <20% remains in bottle.

7.11 Secondary Nitrite Standard –

Stock Nitrite Standard 0.70 mL

In a 100 mL volumetric flask, dilute 0.70 mL of Stock Nitrite Standard to volume with reagent water to yield a concentration of 35 $\mu\text{M NO}_2\text{ –N/L}$ (0.49 mg N/L). Write name of preparer, preparation date, standard manufacturer, manufacturer lot number in the Analytical Standard log book. Make fresh every 4 months.

7.12 Aquakem Cleaning Solution –

Clorox 55.0 mL

In a 100 mL volumetric flask, dilute 55.0 mL of Clorox to volume with 45mL reagent water to yield a concentration of 75% Clorox. Write name of preparer, preparation date, reagent manufacturer, manufacturer lot number in the Analytical Reagent log book. Reagent is stable for six months.

8 SAMPLE COLLECTION, PRESERVATION, AND STORAGE

8.1 Water collected for NO_3+NO_2 should be filtered through a Whatman GF/F glass fiber filter (nominal pore size 0.7 μm), or equivalent.

8.2 Water collected for NO_3+NO_2 should be frozen at $\leq -20^\circ\text{C}$. The AutoAnalyzer vial container (sample cups) should be clean and sample rinsed.

8.3 Frozen NO₃+NO₂ samples may be stored up to 28 days. It has been shown that frozen QCS samples up to a year old still fall well within the control limits.

8.4 NO₃+NO₂ samples may be refrigerated at 4° C for no longer than one day.

9 QUALITY CONTROL

9.1 The laboratory is required to operate a formal quality control (QC) program. The minimum requirements of this program consist of an initial demonstration of laboratory capability and the continued analysis of laboratory instrument blanks and calibration standard material, analyzed as samples, as a continuing check on performance. The laboratory is required to maintain performance records that define the quality of data generated.

9.2 Initial Demonstration of Capability

- 9.2.1 The initial demonstration of capability (iDOC) – is used to characterize instrument performance (MDLs) and laboratory performance (analysis of QC samples) prior to the analyses conducted by this procedure.
- 9.2.2 Linear Dynamic Range – LDR (Linear Calibration Range) should be established for NO₃+NO₂ using appropriate eight point calibration curve.
- 9.2.3 Quality Control Sample (QCS/SRM) – When using this procedure, a quality control sample is required to be analyzed at the beginning and end of the run, to verify data quality and acceptable instrument performance. If the determined concentrations are not within ± 3s of the certified values, performance of the determinative step of the method is unacceptable. The source of the problem must be identified and corrected before either proceeding with the initial determination of MDLs or continuing with analyses.
- 9.2.4 Method Detection Limits (MDLs) – MDLs should be established for NO₃+NO₂ using a low level natural water sample, typically three to five times higher than the estimated MDL. To determine the MDL values, analyze seven replicate aliquots of water. Perform all calculations defined in the procedure and report the concentration values in the appropriate units. Calculate the MDL as follows:

$$MDL = S t_{(n-1, 1-\alpha=0.99)}$$

Where,

S = Standard deviation of the replicate analyses.

n=number of replicates

$t_{(n-1, 1-\alpha=0.99)}$ = Student's *t* value for the 99%

confidence level with n-1 degrees of freedom

(*t*=3.14 for 7 replicates.)

MDLs should be determined annually, whenever there is a significant change in instrumental response or a significant change in instrument configuration.

9.3 Assessing Laboratory Performance

- 9.3.1 Laboratory Reagent Blank (LRB) – The laboratory must analyze at least one LRB with each batch of samples. The LRB consists of reagent water treated the same as the samples. An amount of analyte above the MDL found in LRB indicates possible reagent or laboratory environment contamination. LRB data are used to assess and correct contamination from the laboratory environment.
- 9.3.2 Quality Control Sample (QCS)/ Standard Reference Material (SRM) – When using this procedure, a quality control sample is required to be analyzed at the beginning of the run and end of the run, to verify data quality and acceptable instrument performance. If the determined concentrations are not within $\pm 3s$ of the certified values, performance of the determinative step of the method is unacceptable. The source of the problem must be identified and corrected before either proceeding with the initial determination of MDLs or continuing with the analyses. The results of these QCS/SRM samples shall be used to determine batch acceptance.
- 9.3.3 The QCS are obtained from a source external to the laboratory and different from the source of calibration standards.
- 9.3.4 Control Charts – The Accuracy Control Chart for QCS/SRM samples and reagent blanks is constructed from the average and standard deviation of the 20 most recent QCS/SRM measurements. The accuracy chart includes upper and lower warning levels ($WL=\pm 2s$) and upper and lower control levels ($CL=\pm 3s$). These values are derived from stated values of the QCS/SRM. The standard deviation (s) is specified relative to statistical confidence levels of 95% for WLs and 99% for CLs. Enter QCS/SRM results on the chart each time the sample is analyzed
- 9.3.5 Calibration Verification, Initial and Continuing (ICV/CCV) – Immediately following calibration (ICV) and following every 18-23 samples (CCV), one CCV of 10 μM NO_3 (0.14 mg N/L) NiRMID, 35 μM NO_3 (0.49 mg N/L) NiRHI, 200 μM NO_3 (2.8 mg N/L) NiRXH is analyzed to assess instrument performance. The CCVs are made from the same material as calibration standards (KNO_3), and are to be within $TV \pm 3s$. Failure to meet the criteria requires correcting the problem, including reanalysis of any affected samples. If not enough sample exists, the data must be qualified if reported.
- 9.3.6 Reduction Efficiency Verification (REV) – The REVs are made from NaNO_2 , 35 μM NO_2 (0.49 mg N/L) and are to be within the expected value $\pm 3s$ of the equivalent CCV, 35 μM NO_3 (0.49 mg N/L). Failure to meet the criteria requires correcting the problem.

9.4 Assessing Analyte Recovery – Percent Recovery

9.4.1 Analyte recovery is assessed through percent recoveries of laboratory spikes of samples.

$$9.4.2 \quad \text{Percent Recovery} = (\text{Actual/Expected}) \times 100$$

9.5 Assessing Analyte Precision – Relative Percent Difference

9.5.1 Analyte replication is assessed through duplicate analyses of samples – Relative Percent Difference.

$$9.5.2 \quad \text{RPD} = (\text{Laboratory Duplicate Result 1} - \text{Laboratory Duplicate Result 2}) / [(\text{Laboratory Duplicate Result 1} + \text{Laboratory Duplicate Result 2}) / 2] \times 100$$

9.6 Corrective Actions for Out of Control Data

9.6.1 Control limit – If one measurement exceeds Accuracy Control Chart CL, repeat the analysis immediately. If the repeat measurement is within the CL, continue analyses; if it exceeds the CL, discontinue analyses and correct the problem.

9.6.2 Warning limit – If two out of three successive points exceed Accuracy Control Chart WL, analyze another sample. If the next point is within WL, continue analyses; if the next point exceeds the WL, evaluate potential bias and correct the problem.

9.6.3 Trending – If seven successive Accuracy Control Chart measurements are on the same side of the central line, discontinue analyses and correct the problem.

9.6.4 When external QCS samples are out of control, correct the problem. Reanalyze the samples analyzed between the last in-control measurement and the out-of-control one.

9.6.5 When external CCV samples are out of control, correct the problem. Reanalyze the samples analyzed between the last in-control measurement and the out-of-control one.

9.7 General Operation - To assure optimal operation and analytical results, the Reagent Blank and CCV are tracked daily in the raw data file, copied to Reagent Blank and CCV Control Charts.

Table 2

QC Indicator	Acceptance/ Action Limits	Action	Frequency (Batch)
Correlation Coefficient	≥ 0.995	If <0.995, evaluate data points of the calibration curve. If any data point is outside established limits, reject as outlier.	1 per batch if acceptable.
Quality Control Sample (QCS)/ Certified Reference Material (CRM)	± 10%	If QCS value is outside ± 10% of the target value reject the run, correct the problem and rerun samples.	Beginning of run and at end of run.

Initial Calibration Verification (ICV)	± 10%	Recalibrate if outside acceptance limits.	Beginning of run following standard curve.
Continuing Calibration Verification (CCV)	± 10%	If outside 10%, correct the problem. Rerun all samples following the last in-control CCV.	After every 18-23 samples.
Method Blank/Laboratory Reagent Blank (LRB)	≤ Method Quantitation Limit	If the LRB exceeds the quantitation limit, results are suspect. Rerun the LRB. If the concentration still exceeds the quantitation limit, reject or qualify the data, or raise the quantitation limit.	Following the ICV and after every 18-23 samples following the CCV.
Laboratory Fortified Sample Matrix Spike	± 10%	If the recovery of any analyte falls outside the designated acceptance limits and the QCS is in control, the recovery problem is judged matrix induced. Repeat the LFM and if the sample results are again outside the acceptable recovery range, the sample should be reported with a “matrix induced bias” qualifier.	1/10 (spike OR duplicate)
Laboratory Duplicate	± 10%	If the RPD fails to meet the acceptance limits, the samples should be reanalyzed. If the RPD again fails to meet the acceptance limits, the sample must be reported with a qualifier identifying the sample analysis result as not having acceptable RPD for duplicate analysis.	1/10 (spike OR duplicate)

10 CALIBRATION AND STANDARDIZATION

10.1 Calibration – Daily calibration must be performed before sample analysis may begin. Eight point calibrations are used with each of the three sub-calibrations that cover the analytical range. Five working nitrate standards are used to produce the calibrators for each set of three calibration curves. The

instrument performs serial dilutions of working standards to produce the eight calibrators defined for each curve. The following outlines the preparation of the working standards and the following table describes the subsequent serial dilutions the instrument performs to make each standard for each of the three calibration curves.

NO23 Working Standards:

NiRMID

Working Standard 0.7 mg N/L (1.0 mL stock to 100 mL)

Working Standard 0.28 mg N/L (0.4 mL stock to 100 mL)

NiRHI

Working Standard 2.8 mg N/L (4 mL stock to 100 mL)

Working Standard 0.7 mg N/L (1.0 mL stock to 100 mL)

NiRXHI

Working Standard 5.6 mg N/L (8.0 mL stock to 100 mL)

Working Standard 22.4 mg N/L (32 mL stock to 100 mL)

NO23 Calibrators:

	Working Standard mg/L N	Dilution Factor	Concentration mg/L N
NiRMID	0.28	9+1	0.028
	0.28	7+1	0.035
	0.28	5+1	0.04667
	0.28	3+1	0.07
	0.28	1+1	0.140
	0.7	3+1	0.175
	0.7	2+1	0.233
	0.28	0+1	0.280
NiRHI	0.7	9+1	0.070
	0.7	5+1	0.11667
	0.7	4+1	0.140
	0.7	2+1	0.233
	0.7	1+1	0.350
	2.8	5+1	0.46667
	2.8	4+1	0.560
	0.7	0+1	0.700
NiRXH	5.6	9+1	0.560
	5.6	5+1	0.933
	5.6	4+1	1.120
	5.6	2+1	1.86667
	5.6	1+1	2.800

	22.4	5+1	3.733
	22.4	4+1	4.480
	5.6	0+1	5.600

10.2 The instrument software prepares a standard curve for each set of calibrators. This is viewed by displaying a second order calibration. The second order graph plotting measured absorbance against standard concentration is presented for review and approval. If acceptance criteria are not met the entire curve can be reanalyzed or individual standards can be reanalyzed. One standard value (original or reanalyzed) for each and every standard is incorporated in the curve. The coefficient of determination (Pearson's r value) for the calibration curve as well as the calculated concentration of each calibrator is reviewed. The calculated value of each calibrator must be within ten percent of the expected value. The coefficient of determination (Pearson's r value) for the calibration curve must be greater than 0.995.

11 PROCEDURE – DAILY OPERATIONS QUALITY CONTROL

- 11.1 Turn on computer. Computer will automatically initiate Konelab software. Once software is running, turn on instrument and allow connection between instrument and computer to complete.
- 11.2 Discard any water remaining in the water reservoir from the previous analytical run. Fill the water reservoir with fresh reagent water.
- 11.3 Remove from freezer samples to be analyzed. Allow samples to begin thawing. Begin daily bench sheet documentation. Remove nitrate reductase and NADH vials from freezer.
- 11.4 Place cuvette waste box into cuvette waste sliding drawer.
- 11.5 Once water reservoir is full, use instrument software to click More, Instrument Actions, and Perform Water Wash.– complete at least five perform water wash cycles.
- 11.6 After performing water washes, clean the dispensing needle by performing test washes. Click More, Instrument Actions, More, Adjustment Program. Once in the Adjustment Program click, 4-Dispensing Unit, 1-Dispenser, 8-Test Wash. Perform 8 to 10 Test Washing. When complete, press “Q” to quit until you are able to bring up the Main Page.
- 11.7 Perform Start Up operations by clicking Start Up at the bottom of the Main Page.
- 11.8 Gather working standards and reagents from refrigerator during startup. Assess standards and reagents. Remake anything that has exceeded the time over which it is considered stable. Nitrate reductase and NADH reagents are to be made fresh for every analytical run.
- 11.9 Once startup is complete, check the instrument water blank by clicking More, Instrument Actions, More, Check Water Blank. If any of the instrument blanks are outside their predefined and software controlled limits, the user will be notified on the main menu page. User takes corrective action to return instrument functions to controlled limits.

- 11.10 Load reagents into reagent carousel and place into refrigerated reagent compartment. Reagent positions can be found by clicking reagents at the top of the main page.
- 11.11 Load working standards into a sample segment, identify the standards in their positions from the drop down menus at the individual segment positions, and load into instrument. (Click Samples from the top of the Main Page, then click desired segment number.)
- 11.12 Select the methods to be calibrated by clicking Calibr./QC Selection on the bottom of the main page.. Click NiRMID, NiRHI and NiRXH as the three methods to be calibrated, then click Calibrate at the bottom of the page. The three methods will now show as pending. Return to the main page..
- 11.13 Start instrument and calibration by clicking Page Up on the keyboard. This may also be a green button on the keyboard – See test flow below for stepwise instrument functions for the analysis of standards and samples.

Test Flow – Method of Analysis, Stepwise

- 55 µL NiR AtNaR to cuvette
 - 5 µL sample to cuvette with mixing
 - 15 µL NiR NADH to cuvette with mixing
 - Incubation, 600 seconds, 37°C
 - 25 µL sulfanilamide (SAN) reagent to cuvette with mixing
 - Incubation, 120 seconds, 37°C
 - 25 µL N-1-Naphthylethylenediamine dihydrochloride (NED) reagent to cuvette with mixing
 - Incubation, 120 seconds, 37°C
 - End point absorbance measurement, 540 nm
 - Side-wavelength measurement, 700 nm
 - Software processes absorbance value, side wave length value and uses calibration curve to calculate analyte concentration (mg/L N as NO₂)
 - User is notified if any measured values used to calculate final concentration are outside preset limits. If so, analyst has options to accept results, rerun the sample or rerun the sample diluted to a user or software specified factor.
 - User is notified of each side wave length value. Side wave length >0.005 absorbance units indicates a scratched cuvette or turbid sample. If the side wave length value exceeds 0.005 absorbance units, the analyst specifies that the sample is reanalyzed. If the side wave length of the reanalyzed sample is <0.005 absorbance units, the reanalyzed result is accepted. If the same concentration and side wave length >0.005 absorbance units is again obtained, the results are accepted.
- 11.14 Organize samples, reagent blanks, check standards and all quality control samples while instrument performs calibrations.
- 11.15 As calibration curves are produced by the instrument, review them for acceptability. The instrument software prepares a standard curve for each set of calibrators. A graph plotting measured absorbance against standard concentration is presented for review and approval. If acceptance criteria are not met, either the entire curve shall be reanalyzed or individual standards shall be reanalyzed,

- depending on the violation. One standard value (original or reanalyzed) for each and every calibrator is incorporated in the curve.
- 11.16 Once calibration curves are accepted, samples are loaded into the sample segments and loaded into the instrument for analysis. After the Reagent Blank, the first samples analyzed should be ICV (initial calibration verification) samples. There should be one sample for each calibration curve, of a concentration close to the middle of each range. The following are the recommended ICV samples for each curve: 0.14 mg N/L NiRMID, 0.49 mg N/L NiRHI and 2.8 mg N/L NiRXH. Secondary Nitrite Standard (REV) (0.49 mg N/L) should be analyzed and compared with 0.49 mg N/L ICV to determine reduction efficiency.
- 11.17 Samples are loaded into the segments and analyzed. CCV (Continuing Calibration Verification) samples (one for each of the three calibration ranges) follow every 18-23 samples. Standard Reference Material (SRM) samples, as well as Laboratory Reagent Blanks (LRB) are scattered throughout the analytical batch. Throughout the analytical batch, samples are chosen as laboratory duplicates and laboratory spikes to assess analyte precision and analyte recovery, respectively. The total number of duplicates and spikes performed will be equal to or greater than ten percent of the total number of samples in the analytical batch.
- 11.18 As sample analysis is complete, results must be reviewed and accepted manually. If results fall outside acceptance limits, the sample should be reanalyzed. If sample result exceeds the highest standard of the highest calibration range, the samples can be automatically diluted by the instrument and reanalyzed. If the result is such that it will fall within a higher calibration range, it should be reanalyzed in the higher range. If the result is such that it will fall within a lower calibration range, it should be reanalyzed within the lower range. If the result falls below the lowest standard of the lowest calibration range, the result should be discarded and the sample should be analyzed via cadmium reduction method.
- 11.19 Upon completion of all analysis, results are saved to a daily report file. Click Report on the bottom of the main page, More, Results To File, and select one row per result. The file is then named by the run date. The daily report file for analytical batch of January 1, 2015 would be named 010115. The file is converted to Microsoft Excel for data work up. Remaining samples are discarded.
- 11.20 All reagents are removed from the reagent chamber and returned to the refrigerator. Reagents that have exceeded their stability period are discarded.
- 11.21 Click on Stand By on the bottom of the main page and insert Aquakem Cleaning Solution into the instrument. This initiates shut down procedures. Daily files are cleared from the instrument software by clicking More, Management, Clear Daily Files. The software is exited and the instrument is turned off. The computer is turned off.
- 11.22 The waste is flushed down the drain with copious amounts of tap water. The waste cuvette box is moved to the fume hood and covered. The incubator cover plate is removed. The incubator is wiped clean. The cover is cleaned and returned to its original position.

12 DATA ANALYSIS AND CALCULATIONS

- 12.1 Upon completion of all analysis, results are saved to a daily report file. The file is named by the run date. The daily report file for analytical batch of January 1, 2015 would be named 010115. The file is converted to Microsoft Excel for data work up. The instrument software has calculated final sample concentration from the designated standard curve, correcting each concentration for associated side wave length and also for any user or instrument specified dilution. Dilution by the instrument is noted by software as analysis ensues and, also, documented in the Excel data report file. The analyst examines each row of data. Results are eliminated that are outside the limits of the calibration range, or have an unrepeated side wave length measurement greater than 0.005 absorbance units.

13 REFERENCES

- 13.1 Campbell, et al. (2006). Nitrate reductase for nitrate analysis in water. Environ Chem Letters 4:69. <http://www.nitrate.com/ECL2006.pdf>
- 13.2 Frank, J. M., C.F. Zimmermann and C. W. Keefe (2006). Comparison of results from Konelab Aquakem 250 and existing nutrient analyzers. UMCES CBL Nutrient Analytical Services Laboratory, Dec. 2006.
- 13.3 Patton, et al. (2002). Corn leaf nitrate reductase – a nontoxic alternative to cadmium for photometric nitrate determinations in water samples by air-segmented continuous-flow analysis, Environ. Sci Tech. 2002, 36, 729-735. <http://www.nitrate.com/pattonetal2002.pdf>
- 13.4 <http://www.nitrate.com/nar-nam1.htm>

University of Maryland Center for Environmental Science
Chesapeake Biological Laboratory
Nutrient Analytical Services
146 Williams St., Solomons, MD 20688
<http://nasl.cbl.umces.edu/>

**Standard Operating Procedure for
Determination of Aqueous Inorganic Carbon and calculated Carbonate Alkalinity
in waters of Fresh/Estuarine/Coastal Waters.**

(References: ASTM D7573-09)

Revision 2017-1
Replaces Revision 2016
Effective April 27, 2017

Revised by: _____ Date: _____

Reviewed by: _____ Date: _____

Laboratory Supervisor: _____ Date: _____

Changes affecting Revision 2016

Section 1.3: The LOQ/Reporting Limit was changed to 1.00 mg/L, which is the lowest standard.

Section 1.6: Added: and references ASTM 7573.09.

Section 3.5: Definition of preparation batch removed.

Section 3.30: Added: also known as the MDL.

Section 3.31: Added: Also known as the Quantitation Limit.

Section 3.40: Added: Also known as CRM.

Section 3.42: Removed: and including the transfer of run cycle data to the disc.

Section 3.47: Added: Also known as CRM.

Section 5: Safety Table updated.

Section 6.2: changed to $+4 \pm 2^\circ \text{C}$

Section 6.3: added language to address baking glassware and running clean check blanks.

Section 7.3: changed reagent sodium bicarbonate (0.875g) and sodium carbonate (1.1025 g) weights to reflect concentration within 250 ml. Make fresh within 4 months.

Section 7.5: Replaced ASTM D1193, Type I water with Reagent water, as defined in

Section 7.1. Removed: The LRB is comprised of the instrument blank. The area of the LRB is subtracted from the area of the standards.

Section 8.2: Changed wording to “The holding time for frozen TIC samples is 28 days. It has been shown that frozen QCS samples up to a year old still fall well within the control limits, therefore if frozen samples are stored longer than the holding time, there is minimal degradation.”

Section 8.3: Replaced 4°C with $\leq 6^\circ \text{C}$.

Section 9.2.2: Added: Linear Dynamic Range (LDR) – The linear dynamic range for TIC should be established using a blank and four or more appropriate standards for the calibration curve

Section 9.2.3: Changed QCS/SRM to QCS/CRM. $\pm 10\%$ changed to $\pm 3\sigma$.

Section 9.3.1: Replaced ASTM Type I water with reagent water.

Section 9.3.4: Added: and the slope, y-intercept, and correlation coefficient data are compiled and tracked. The CRM concentrations should fall within $\pm 3\sigma$ of the expected value. The Accuracy Control Chart for QCS/CRM samples is constructed from the average and standard deviation of the QCS/CRM measurements per batch. The accuracy chart includes upper and lower control levels ($CL = \pm 3\sigma$). These values are derived from stated values of the QCS/SRM. The standard deviation (σ) is specified relative to statistical confidence levels of 99% for CLs. Enter QCS/CRM results on the chart each time the sample is analyzed

Section 9.3.5: Added: Calibration Verification – Initial Calibration Verification (ICV) - Immediately following the calibration curve, all standards are analyzed to confirm the calibration. Continuing Calibration Verification (CCV) - Following every 10-12 samples, one or two CCVs are analyzed to assess instrument performance. The CCVs are made from the same material as calibration standards. Replaced TV $\pm 3\sigma$ with $\pm 3\sigma$ of the expected value.

Section 9.5.1: Correlation Coefficient changed from 0.9990 to 0.995 and r^2 replaced with correlation coefficient.

QC Indicator Table: Correlation Coefficient changed from 0.9990 to 0.995. QCS Frequency changed to include - and at end bracketed by final CCVs.

QC Indicator Table: QCS action: Added: If the QCS value falls between ± 10 -20%, blanks and STDs must fall within range before accepting data.

QC Indicator Table: Acceptance Limits for ICV and CCV changed to 10%.

10.1.1: Absolute value of the y intercept added to the calculation of TIC. Corrected equation for Carbonate Alkalinity.

Appendix 1 Procedure: Updated file of 3/29/17 on running the TOC-L for inorganic carbon replaced old procedure.

Bench Sheet table: Replaced old format with new format.

1. SCOPE and APPLICATION

- 1.1 Aqueous inorganic carbon (TIC) is determined by wet chemical analysis where a measured sample is injected with a percentage of 1N hydrochloric acid. The carbonates are reduced to CO₂ and are detected using a non-dispersive infrared detector (NDIR) of an organic carbon analyzer. Carbonate alkalinity is calculated using the TIC concentration. The method is used to analyze all ranges of salinity.
- 1.2 A Method Detection Limit (MDL) of 0.17 mg/L TIC was determined using the Student's *t* value (3.14, n=7) times the standard deviation of a minimum of 7 replicates. If more than seven replicates are used to determine the MDL, refer to the Student's *t* test table for the appropriate n-1 value.
- 1.3 The quantitation limit/reporting limit for TIC was set at 1.00 mg/L C, which is the lowest standard.
- 1.4 This procedure should be used by analysts experienced in the theory and application of inorganic carbon analysis. A three month training period with an analyst experienced in the analysis using the organic carbon analyzer is required.
- 1.5 This method can be used for all programs that require analysis of aqueous inorganic carbon.
- 1.6 This procedure follows the procedures set forth within the operating manual of the Shimadzu TOC-L and references ASTM D7573-09.

2. SUMMARY

- 2.1 The Shimadzu TOC-L is a high temperature combustion instrument used to analyze aqueous samples for TIC, TOC and non-purge-able organic carbon (NPOC).
- 2.2 An aliquot of sample is pulled into the sampling syringe. A percentage of 1N hydrochloric acid (HCl) is injected into the syringe and the combined solution is bubbled for a measured time. The carbonates within the sample are reduced to carbon dioxide (CO₂). The CO₂ is carried by ultra pure air to a non-dispersive infrared detector (NDIR) where CO₂ is detected.
- 2.3 Carbonate alkalinity is then calculated after the concentration of inorganic carbon is determined.

3. DEFINITIONS

- 3.1 Acceptance Criteria – Specified limits placed on characteristics of an item, process, or service defined in a requirement document. (ASQC)
- 3.2 Accuracy – The degree of agreement between an observed value and an accepted reference value. Accuracy includes a combination of random

error (precision) and systematic error (bias) components which are due to sampling and analytical operations; a data quality indicator. (QAMS)

- 3.3 Aliquot – A discrete, measured, representative portion of a sample taken for analysis. (EPA QAD Glossary)
- 3.4 Analytical Range – 0-3000 mg/L using 5 ml syringe and 10-4500 µl (variable) injection volume, using regular sensitivity catalyst.
- 3.5 Batch – Environmental samples, which are prepared and /or analyzed together with the same process and personnel, using the same lot(s) of reagents. An **analytical batch** is composed of prepared environmental samples (extracts, digestates, or concentrates) and/or those samples not requiring preparation, which are analyzed together as a group using the same calibration curve or factor. An analytical batch can include samples originating from various environmental matrices and can exceed 20 samples. (NELAC/EPA)
- 3.6 Blank- A sample that has not been exposed to the analyzed sample stream in order to monitor contamination during sampling, transport, storage or analysis. The blank is subjected to the usual analytical and measurement process to establish a zero baseline or background value and is sometimes used to adjust or correct routine analytical results. (ASQC)
- 3.7 Calibrate- To determine, by measurement or comparison with a standard, the correct value of each scale reading on a meter or other device, or the correct value for each setting of a control knob. The levels of the applied calibration standard should bracket the range of planned or expected sample measurements. (NELAC)
- 3.8 Calibration – The set of operations which establish, under specified conditions, the relationship between values indicated by a measuring device. The levels of the applied calibration standard should bracket the range of planned or expected sample measurements. (NELAC)
- 3.9 Calibration Curve – The graphical relationship between known values, such as concentrations, or a series of calibration standards and their analytical response. (NELAC)
- 3.10 Calibration Method – A defined technical procedure for performing a calibration. (NELAC)
- 3.11 Calibration Standard – A substance or reference material used to calibrate an instrument. (QAMS)
 - 3.11.1 Initial Calibration Standard (STD) – A series of standard solutions used to initially establish instrument calibration responses and develop calibration curves for individual target analytes.
 - 3.11.2 Initial Calibration Verification (ICV) – An individual standard, analyzed initially, prior to any sample analysis, which verifies acceptability of the calibration curve or previously established calibration curve.

- 3.11.3 Continuing Calibration Verification (CCV) – An individual standard which is analyzed after every 10-15 field sample analysis.
- 3.12 Certified Reference Material (CRM) – A reference material one or more of whose property values are certified by a technically valid procedure, accompanied by or traceable to a certificate or other documentation which is issued by a certifying body. (ISO 17025)
- 3.13 Combustion tube – Quartz tube filled with platinum catalyst, heated to 680° C, into which the sample aliquot is injected.
- 3.14 Conditioning Blank – Reagent water (ASTM Type I) run before the calibration curve to decrease the instrument blank and stabilize the column conditions.
- 3.15 Corrective Action – Action taken to eliminate the causes of an existing nonconformity, defect or other undesirable situation in order to prevent recurrence. (ISO 8402)
- 3.16 Deficiency – An unauthorized deviation from acceptable procedures or practices. (ASQC)
- 3.17 Demonstration of Capability – A procedure to establish the ability of the analyst to generate acceptable accuracy. (NELAC)
- 3.18 Detection Limit – The lowest concentration or amount of the target analyte that can be determined to be different from zero by a single measurement at a stated degree of confidence.
- 3.19 Duplicate Analysis – The analyses of measurements of the variable of interest performed identically on two sub samples (aliquots) of the same sample. The results from duplicate analyses are used to evaluate analytical or measurement precision but not the precision of sampling, preservation or storage internal to the laboratory. (EPA-QAD)
- 3.20 External Standard (ES) – A pure analyte (sodium carbonate/sodium bicarbonate ($\text{Na}_2\text{CO}_3/\text{NaHCO}_3$)) that is measured in an experiment separate from the experiment used to measure the analyte(s) in the sample. The signal observed for a known quantity of the pure external standard is used to calibrate the instrument response for the corresponding analyte(s). The instrument response is used to calculate the concentrations of the analyte(s) in the unknown sample.
- 3.21 Field Duplicates (FD1 and FD2) – Two separate samples collected at the same time and place under identical circumstances and treated exactly the same throughout field and laboratory procedures. Analyses of FD1 and FD2 provide a measure of the precision associated with sample collection, preservation and storage, as well as with laboratory procedures.
- 3.22 Field Reagent Blank (FRB) – A aliquot of reagent water or other blank matrix that is placed in a sample container in the laboratory and treated as a sample in all respects, including shipment to the sampling site, exposure to the sampling site conditions, storage, preservation, and all analytical procedures. The purpose of the FRB is to determine if method analytes or other interferences are present in the field environment.

- 3.23 Furnace – Heats the combustion tube to the operating temperature of 680° C.
- 3.24 Holding time – The maximum time that samples may be held prior to analysis and still be considered valid. (40 CFR Part 136) The time elapsed from the time of sampling to the time of extraction or analysis, as appropriate.
- 3.25 Injection – The sample aliquot that is drawn into the syringe and injected into the combustion tube.
- 3.26 Instrument Detection Limit (IDL) – The minimum quantity of analyte of the concentration equivalent which gives an analyte signal equal to three times the standard deviation of the background signal at the selected wavelength, mass, retention time absorbance line, etc.
- 3.27 Laboratory Duplicates (LD1 and LD2) – Two aliquots of the same sample taken in the laboratory and analyzed separately with identical procedures. Analyses of LD1 and LD2 indicate precision associated with laboratory procedures, but not with sample collection, preservation, or storage procedures.
- 3.28 Laboratory Reagent Blank (LRB) – A matrix blank (i.e., reagent water) that is treated exactly as a sample including exposure to all glassware, equipment, solvents, and reagents that are used with other samples. The LRB is used to determine if method analytes or other interferences are present in the laboratory environment, the reagents, or the instrument.
- 3.29 Laboratory Control Sample (LCS) – A sample matrix, free from the analytes of interest, spiked with verified known amounts of analytes from a source independent of the calibration standard or a material containing known and verified amounts of analytes. The LCS is generally used to establish intra-laboratory or analyst-specific precision and bias or to assess the performance of all or a portion of the measurement system. (NELAC)
- 3.30 Limit of Detection (LOD) – The lowest concentration level that can be determined by a single analysis and with a defined level of confidence to be statistically different from a blank (ACS), also known as the MDL.
- 3.31 Limit of Quantitation (LOQ) – The minimum levels, concentrations, or quantities of a target variable (target analyte) that can be reported with a specified degree of confidence. The LOQ is set at 3 to 10 times the LOD, depending on the degree of confidence desired. Also known as the Quantitation Limit.
- 3.32 Linear Dynamic Range (LDR) – The absolute quantity over which the instrument response to an analyte is linear. This specification is also referred to as the Linear Calibration Range (LCR).
- 3.33 Material Safety Data Sheets (MSDS) – Written information provided by vendors concerning a chemical's toxicity, health hazards, physical properties, fire, and reactivity data including storage, spill, and handling precautions.
- 3.34 May – Denotes permitted action, but not required action. (NELAC)

- 3.35 Method Detection Limit (MDL) – The minimum concentration of an analyte that can be identified, measured, and reported with 99% confidence that the analyte concentration is greater than zero.
- 3.36 Must – Denotes a requirement that must be met. (Random House College Dictionary)
- 3.37 Non-Dispersive Infrared Detector (NDIR) – The detector found in the Shimadzu TOC-L analyzer. Carbon dioxide is detected.
- 3.38 Precision – The degree to which a set of observations or measurements of the same property, obtained under similar conditions, conform to themselves; a data quality indicator. Precision is usually expressed as standard deviation, variance or range, in either absolute or relative terms. (NELAC)
- 3.39 Preservation – Refrigeration, freezing, and/or reagents added at the time of sample collection (or later) to maintain the chemical and or biological integrity of the sample.
- 3.40 Quality Control Sample (QCS) – A sample of analytes of known and certified concentrations. The QCS is obtained from a source external to the laboratory and different from the source of calibration standards. It is used to check laboratory performance with externally prepared test materials. Also known as CRM.
- 3.41 Run – One sample analysis from start to finish, including printout.
- 3.42 Run Cycle – Typically a day of operation – the entire analytical sequence of runs from the first run to the last run.
- 3.43 Sample Volume – Amount of sample injected into the combustion tube.
- 3.44 Sensitivity – The capability of a test method or instrument to discriminate between measurement responses representing different levels (concentrations) of a variable of interest.
- 3.45 Shall – Denotes a requirement that is mandatory whenever the criterion for conformance with the specification requires that there be no deviation. (ANSI)
- 3.46 Should – Denotes a guideline or recommendation whenever noncompliance with the specification is permissible. (ANSI)
- 3.47 Standard Reference Material (SRM) – Material which has been certified for specific analytes by a variety of analytical techniques and/or by numerous laboratories using similar analytical techniques. These may consist of pure chemicals, buffers, or compositional standards. The materials are used as an indication of the accuracy of a specific analytical technique. Also known as CRM.





4. INTERFERENCES

- 4.1 Carbon dioxide is readily absorbed from the air into an aqueous sample. Care must be taken to avoid this. Sample collection bottles should be filled to the brim with no head space. Standards should be prepared in small batches and used within 1-2 days of preparation. Sample vials should be covered when placed in the auto sampler.

5. SAFETY

- 5.1 Safety precautions must be taken when handling reagents, samples and equipment in the laboratory. Protective clothing including lab coats, safety glasses and enclosed shoes should be worn. In certain situations, it will be necessary to also use gloves and/or a face shield. If solutions come in contact with eyes, flush with water continuously for 15 minutes. If solutions come in contact with skin, wash thoroughly with soap and water. Contact Solomons Rescue Squad (911) if emergency treatment is needed and also inform the CBL Associate Director of Administration of the incident. Contact the CBL Associate Director of Administration if additional treatment is required.
- 5.2 The toxicity or carcinogenicity of each reagent used in this procedure may not have been fully established. Each chemical should be regarded as a potential health hazard and exposure should be as low as reasonably achievable. Cautions are included for known hazardous materials and procedures.
- 5.3 Do not wear jewelry when troubleshooting electrical components. Even low voltage points are dangerous and can injure if allowed to short circuit.
- 5.4 The following hazard classifications are listed for the chemicals used in this procedure. Detailed information is provided on Material Safety Data Sheets (MSDS).

Table 1:

Chemical	Health Hazard	Fire Hazard	Instability Hazard	Specific Hazard	
Sodium Carbonate, Anhydrous	2	0	1	Irritant	
Sodium Bicarbonate	1	0	0		
Hydrochloric Acid	3	0	2	ACID, COR	
Sodium Hydroxide	3	0	1	ALK, COR	
Platinum Catalyst on Alumina Beads	1	0	0		
Soda Lime	3	0	0	COR	

On a scale of 0 to 4 the substance is rated on four hazard categories: health, flammability, reactivity, and contact. (0 is non-hazardous and 4 is extremely hazardous)

HAZARD RATING

Health Hazard - Blue: 4 – deadly, 3 – extreme danger, 2 – hazardous, 1 – slightly hazardous, 0 – normal material

Fire Hazard - Red: Flash Points: 4 – below 73° F, 3 – below 100° F, 2 – below 200° F, 1 – above 200° F, 0 – will not burn

Instability Hazard - Yellow: 4 – may detonate, 3 – Shock and heat may detonate, 2 – violent chemical change, 1 – unstable is heated, 0 - stable

Specific Hazard - White: Acid = ACID, Alkali = ALK, Corrosive = COR, Oxidizer = OXY

6. EQUIPMENT AND SUPPLIES

6.1 A Total Organic Carbon Analyzer capable of maintaining a combustion temperature of 680° C and analyzing for organic and inorganic carbon. The Shimadzu TOC-L is used in this laboratory.

6.2 Refrigerator, capable of maintaining $+4 \pm 2^\circ$ C.

6.3 Lab ware – All reusable lab ware (glass, Teflon, plastic, etc) should be sufficiently clean for the task objectives. This laboratory soaks all lab ware related to this method in a 10% HCl (v/v) acid bath overnight and rinses copiously with reagent (ASTM Type I) water, as well as bakes the glassware at 400° C for at least 1 hour and runs clean check blanks with every run.

7. REAGENTS AND STANDARDS

7.1 Purity of Water – Unless otherwise indicated, references to water shall be understood to mean reagent water conforming to ASTM Specification D 1193, Type I. Freshly prepared water should be used for making the standards intended for calibration. The detection limits of this method will be limited by the purity of the water and reagents used to make the standards.

7.2 Purity of Reagents – Reagent grade chemicals shall be used in all tests. Unless otherwise indicated, it is intended that all reagents shall conform to specifications of the Committee on Analytical Reagents of the American Chemical Society, where such specifications are available. Other grades may be used, provided it is first ascertained that the reagent is of sufficiently high purity to permit its use without compromising the accuracy of the determination

7.3 Sodium Hydrogen Carbonate (NaHCO_3) and Sodium Carbonate (Na_2CO_3) – primary standard for inorganic carbon.

Inorganic Carbon Stock Standard: Sodium Hydrogen Carbonate/ Sodium Carbonate (NaHCO ₃ /Na ₂ CO ₃) Standard,	1000 mg/l
Sodium Hydrogen Carbonate (NaHCO ₃)	0.875 g
Sodium Carbonate, Anhydrous (Na ₂ CO ₃)	1.1025 g
Reagent water	250 ml

In a 250 ml volumetric flask, dissolve 0.875 g NaHCO₃ and 1.1025 g Na₂CO₃ in ~150 ml reagent water. Dilute to 250 ml with reagent water. Make fresh within 4 months. Store at 4° C.

7.4 Hydrochloric Acid – 1N

Hydrochloric Acid (HCl), concentrated,	86 ml
Reagent water, q.s.	1000 ml

In a 1000 ml volumetric flask, add 86 ml of concentrated hydrochloric acid to ~ 500 ml of reagent water. Dilute to 1000 ml with reagent water.

7.5 Blanks – Reagent water, as defined in Section 7.1, is used for the Laboratory Reagent Blank.

7.6 Quality Control Sample (QCS) – For this procedure, the QCS can be any certified dissolved sample which is obtained from an external source. If a certified sample is not available, then use the standard material (Na₂CO₃/NaHCO₃).

8 SAMPLE COLLECTION, PRESERVATION, AND STORAGE

8.1 Water collected for TIC is unfiltered whole water and should not be acidified. The sample container may be any container which has been adequately cleaned. If frozen, freshwater samples should be stored in Teflon or plastic to prevent breakage.

8.2 The holding time for frozen TIC samples is 28 days. It has been shown that frozen QCS samples up to a year old still fall well within the control limits, therefore if the frozen sample is stored for longer than the holding time, there is minimal degradation.

8.3 TIC samples stored at ≤ 6° C should be analyzed within 28 days.

8.4 Sample containers should be filled to the brim with no head space if refrigerated. If frozen, enough space for expansion should be left at the top of the container to prevent breakage.

9 QUALITY CONTROL

9.1 The laboratory is required to operate a formal quality control (QC) program. The minimum requirements of this program consist of an initial demonstration of laboratory capability and the continued analysis of laboratory instrument blanks and calibration standard material, analyzed as samples, as a continuing check on performance. The laboratory is required to maintain performance records that define the quality of data generated.

9.2 Initial Demonstration of Capability

9.2.1 The initial demonstration of capability (iDOC) – is used to characterize instrument performance (MDLs) and laboratory performance (analysis of QC samples) prior to the analyses conducted by this procedure.

9.2.2 Linear Dynamic Range (LDR) – The linear dynamic range for TIC should be established using a blank and four or more appropriate standards for the calibration curve.

9.2.3 Quality Control Sample (QCS/CRM) – When using this procedure, a quality control sample is required to be analyzed at the beginning and end of the run, to verify data quality and acceptable instrument performance. If the determined concentrations are not within $\pm 3\sigma$ of the certified values, performance of the determinative step of the method is unacceptable. The source of the problem must be identified and corrected before either proceeding with the initial determination of MDLs or continuing with analyses.

9.2.4 Method Detection Limits (MDLs) – MDLs should be established for TIC using a low level ambient water sample. To determine the MDL values, analyze a minimum of seven replicate aliquots of water. Perform all calculations defined in the procedure (Section 10) and report the concentration values in the appropriate units. Calculate the MDL as follows:

$$\text{MDL} = S_{t(n-1,1-\alpha=0.99)}$$

Where, $t(n-1,1-\alpha=0.99)$ = Student's t value for the 99% confidence level with $n-1$ degrees of freedom ($t = 3.14$ for 7 replicates)

n = number of replicates

S = Standard Deviation of the replicate analyses.

- 9.2.5 MDLs should be determined yearly or more frequently whenever there is a significant change in instrument response or configuration.

9.3 Assessing Laboratory Performance

- 9.3.1 Laboratory Reagent Blank (LRB) – The laboratory must analyze at least one LRB with each batch of samples. The LRB consists of reagent water treated the same as the samples. LRB data are used to assess contamination from the laboratory environment.
- 9.3.2 Quality Control Sample (QCS)/ Certified Reference Material (CRM) – When using this procedure, a quality control sample is required to be analyzed at the beginning of the run and end of the run, to verify data quality and acceptable instrument performance. If the determined concentrations are not within $\pm 3\sigma$ of the certified values, performance of the determinative step of the method is unacceptable. The source of the problem must be identified and corrected before either proceeding with the initial determination of MDLs or continuing with the analyses. The results of these samples shall be used to determine batch acceptance.
- 9.3.3 The QCS/CRM will be obtained from a source external to the laboratory and different from the source of calibration standards.
- 9.3.4 Control Charts – The CRM data are graphed, and the slope, y-intercept, and correlation coefficient data are compiled and tracked. The CRM concentrations should fall within $\pm 3\sigma$ of the expected value. The Accuracy Control Chart for QCS/CRM samples is constructed from the average and standard deviation of the QCS/CRM measurements per batch. The accuracy chart includes upper and lower control levels ($CL=\pm 3\sigma$). These values are derived from stated values of the QCS/CRM. The standard deviation (σ) is specified relative to statistical confidence levels of 99% for CLs. Enter QCS/CRM results on the chart each time the sample is analyzed
- 9.3.5 Calibration Verification – Initial Calibration Verification (ICV) - Immediately following the calibration curve, all standards are analyzed to confirm the calibration. Continuing Calibration Verification (CCV) - Following every 10-12 samples, one or two CCVs are analyzed to assess instrument performance. The CCVs are made from the same material as calibration standards

($\text{Na}_2\text{CO}_3/\text{NaHCO}_3$), and are to be within $\pm 3\sigma$ of the expected value. Failure to meet the criteria constitutes correcting the problem and reanalyzing the samples. If not enough sample exists, the data must be qualified if reported.

9.4 Assessing Analyte Recovery

- 9.4.1 Matrix spikes are performed on a 20% QA/QC basis.
- 9.4.2 1.0 ml of the highest carbonate standard in the curve is added to 10.0 ml of sample for a total volume of 11.0 ml.
- 9.4.3 1.0 ml standard $1.0/11.0 = 0.09$
- 9.4.4 0.09 X STD conc.
- 9.4.5 10.0 ml sample $10.0/11.0 = 0.91$
- 9.4.6 (original sample conc. X 0.91) + (0.09 x std conc.) =
(expected conc.) mg/L
- 9.4.7 Percent Recovery for each spiked sample should fall within 80-120%. Where:
 $\%SR = (\text{Actual Conc.} / \text{Expected Conc.}) \times 100$
- 9.4.8 Relative Percent Difference (RPD) of duplicated samples should be less than 20%. Where:
 $RPD = \frac{\text{difference of duplicates}}{\text{Average of duplicates}} \times 100$
- 9.4.9 Assess whether the analytical result for the CRM/QCS sample confirms the calibration when calculated as follows
 $\% \text{ Recovery} = \text{AMC}/\text{CRM} \times 100$
Where:
AMC = Average measured concentration of the CRM sample
CRM = Certified value of the CRM
The analytical result must fall with the range of 80-120%

9.5 Data Assessment and Acceptance Criteria for Quality Control Measures

- 9.5.1 The Acceptance Criteria for TIC is 0.995. If the correlation coefficient is less than acceptable, all blanks and standards analyzed during the run may be averaged into the curve.

9.6 Corrective Actions for Out of Control Data

- 9.6.1 If the acceptance criteria are still not met, the samples are to be rerun.

QC Indicator	Acceptance/ Action Limits	Action	Frequency (Batch)
Correlation Coefficient	≥ 0.995	If <0.995 , evaluate data points of the calibration curve. If any data point is outside established limits, reject as outlier.	1 per batch if acceptable.
Quality Control Sample (QCS)/ Certified Reference Material (CRM)	$\pm 10\%$	If the QCS value falls between $\pm 10\text{-}20\%$, blanks and stds must fall within range before accepting data. If QCS value is outside $\pm 20\%$ of the target value reject the run, correct the problem and rerun samples.	Beginning of run following the ICV and at end bracketed by final CCVs.
Initial Calibration Verification (ICV)	$\pm 10\%$	Recalibrate if outside acceptance limits.	Beginning of run following standard curve.
Continuing Calibration Verification (CCV)	$\pm 10\%$	If outside 10%, correct the problem. Rerun all samples following the last in-control CCV.	After every 10-12 samples and at end of batch.
Method Blank/Laboratory Reagent Blank (LRB)	\leq Method Quantitation Limit	If the LRB exceeds the quantitation limit, results are suspect. Rerun the LRB. If the concentration still exceeds the quantitation limit, reject or qualify the data, or raise the quantitation limit.	Following the ICV, after every 10-12 samples following the CCV and at the end of the run.
Method Quantitation Limit (MQL): The concentration of the lowest standard.		When the value is outside the predetermined limit and the ICV is acceptable, reanalyze the sample. If the reanalysis is unacceptable, increase the concentration and reanalyze. If this higher concentration meets the acceptance criteria, raise the reporting limit for the batch.	Beginning of run following the LRB.
Laboratory Fortified Sample Matrix Spike	$\pm 20\%$	If the recovery of any analyte falls outside the designated acceptance limits and the QCS is in control, the recovery problem is judged matrix induced. Repeat the LFM and if the sample results are again	1/20

		outside the acceptable recovery range, the sample should be reported with a “matrix induced bias” qualifier.	
Laboratory Duplicate	± 20%	If the RPD fails to meet the acceptance limits, the samples should be reanalyzed. If the RPD again fails to meet the acceptance limits, the sample must be reported with a qualifier identifying the sample analysis result as not having acceptable RPD for duplicate analysis.	1/10 recommended 1/20 accepted

10 CALIBRATION AND STANDARDIZATION

10.1 Calibration – Daily calibration must be performed before sample analysis may begin. A minimum four-point calibration is used with the Shimadzu TOC-L.

10.1.1 Reagent water is used as the “zero point” in the calibration. The standards are calculated by the following equation:

$$\text{mg TIC/L} = (A_{\text{STD}} - \text{||y intercept||}) / m$$

Where: A_{STD} = Area of the standard
 ||y intercept|| = absolute value of the y intercept
 m = slope of the regression line

TIC sample concentration is calculated using the following equation:

$$\text{mg TIC/L} = (A_{\text{S}} - \text{||y||}) / m$$

Where: A_{S} = area of the sample,
 ||y|| = absolute value of the y intercept
 m = slope of the regression line

Carbonate Alkalinity sample concentration is calculated using the following equation:

$$\text{mg CO}_3/\text{L} = (\text{mg TIC/L}) * (1 \text{ moles C}/12 \text{ g C}) * (60 \text{ g CO}_3/ 1 \text{ mole})$$

example: $17.0 \text{ mg TIC/L} = (17.0 * 60)/12 = 85.0 \text{ mg CO}_3\text{/L}$

11.0 References

Instrument Manual Total Organic Carbon Analyzer Model TOC-L. Shimadzu Scientific Corporation. 7102 Riverwood Drive, Columbia, Maryland 21046-2502. Phone: 410 381-1227.

ASTM D7573-09, Standard Test Method for Total Carbon and Organic Carbon in Water by High Temperature Catalytic Combustion and Infrared Detection, ASTM International, West Conshohocken, PA, 2009, www.astm.org

Appendix I

PROCEDURE

Daily Operations

Refer to the original “Running the TOC-L” on p.19 to start the instrument.

1N HCl is used in the analysis of inorganic carbon and carbonate alkalinity. Switch the 1N HCl to the location next to the dilution H₂O. Move the 9N H₂SO₄ bottle to the empty slot. Insert acid sample line.

Continue to follow the steps to start the TOC-L.

Replace the reagent water with fresh daily. The standards are good for 2 consecutive runs only. Make fresh each time if not running the next day. It is ok to leave the dilution water for several days. It is not used for the standards.

Loading samples: Fill all sample vials to the shoulder, cover with septum and cap. Water readily picks up CO₂ from the air, therefore it is best to leave as little headspace as possible. A spiked sample is the only sample with less volume.

Because of this, plan several small runs, instead of one large run. It is better to run fewer than 20 samples in addition to blanks and standards per run.

One CRM vial filled to the shoulder is all that is needed. The software allows the one vial to be sampled a maximum of 3 times (this depends on the injection volume and # of washes). The CRM should be analyzed after the ICVs and blanks, after the next blank and low CCV, and again at the end bracketed within the final standards.

In creating a new method, select IC instead of NPOC. From there, the method setup is the same.

“Multiple injections” is not an option for IC analysis.

Include several conditioning blanks (minimum of 3) after switching from sulfuric acid to HCl. This replaces the acid for the other before the standard curve. Visually check that the conditioning blanks reach a steady state before running the standard curve. The area of the blank should be below 4.0.

Running the TOC-L

Make sure the 2nd stage of the regulator on the air tank (Air Gas Ultra Zero Grade Air, size A) is set at no higher than 30 psi. Replace the tank when the tank pressure falls below 500 psi.

To turn on instrument, push the on/off switch on right side of instrument to on, and then push button located on front of instrument. The front indicator light will cycle through the colors ending with orange, which means the instrument is in a not-ready state. The indicator light turns green when the instrument is up to temperature and all parameters are OK. The light will be blue while the instrument is running samples. If the indicator light is red, refer to the software and the manual to determine the problem. If necessary, call Shimadzu (1-800-477-1227) for tech support.

Open software by clicking on the TOC-L sample table icon. There is no password. Just hit enter when password screen appears.

Open a new sample table by clicking on NEW in the toolbar. Click OK. Then hit CONNECT located in the tool bar. A sample table must be open to connect the instrument. The furnace automatically turns on.

At this time, refill the dilution, reagent blank, and rinse water bottles. The reagent blank water is in the 500 ml Teflon bottle or brown glass TOC water reagent bottle beside the instrument. The rinse water bottle is located behind the autosampler. The dilution bottle is located on the left side of the instrument along with the 9 N H₂SO₄ bottle, 1 N HCl bottle, and the drain bottle. Sulfuric acid is used in the NPOC analysis, and the HCl is used in the TIC analysis. Check the volume of the acid bottle in use, and the drain bottle. The liquid level of the drain bottle should be just below the arm. 250 mls of 9 N H₂SO₄ or 1 N HCl is plenty for several weeks of analysis. Unless the dilution water is being used to create the standard curve, it is ok to not change daily. Replace weekly regardless.

Open the front door of the instrument and check the liquid level of the humidifier located on the right hand side. The level should be between the high and low marks. Add reagent water as needed by removing cap at top.

Check the level of liquid in the Type B Halogen Scrubber (the long tube next to the syringe which contains the rolled stainless mesh). Add 0.05 M HCl (40 ml reagent H₂O + 1 ml 1N HCl) so that the level is an inch or so above the level of the mesh screen. There is a small drain line attached to the 8-port valve at port 6 which is frequently pulled out of the drain when removing the cap of the Type B Halogen Scrubber. When recapping the scrubber, ALWAYS check that the small tubing from port 6 on the 8 port

valve is in the black capped drain port behind the scrubber. Replace the 0.05 M HCl 100% each time the column is changed.

It is recommended that these next two steps should be performed before each run. An explanation of the Maintenance Menus can be found in the User's Manual, Chapter 7.6 p.302-308.

Before running blanks or beginning a sample run, from the program, select Instrument and Maintenance. Click on Residue Removal, then click start. Close when finished.

Next, under Instrument Maintenance, select Replace Flowline Content, and then click start. Close when finished.

If the instrument has been sitting unused, or if several runs of high salt samples have been analyzed, perform a TC Regeneration. Again, under Instrument Maintenance, select Regeneration of TC Catalyst, and then click start. This takes several minutes. Close when finished.

Loading samples: Read Section in Full before proceeding.

The volume of the sample vial is 24 mls. The volume of the Teflon bottles is 30 mls, which means, in most cases, the analysis is volume limited. Fill the sample vial between half and $\frac{3}{4}$ full. The absolute minimum volume to use in the sample vial is 10 mls. Choose a sample with maximum volume in the Teflon bottle ahead of time to be the QA sample for duplicates or to make a spike. Cover each sample vial with a septum (or foil square if not available) and secure with an open septum cap.

Standard Curve:

The reagent blank water is in the bottle beside the instrument. This bottle is considered Position 0 on the sample wheel.

Load the other standards in the curve in the first several slots of the wheel.

QA/QC

Analyze a certified reference control sample (CRM) at least 3 times during the run. With each batch of control samples, a method is created in the control sample folder. To insert a control sample, highlight the line in the sample table. Click on INSERT on the tool bar, and then click on Control Sample. Once the folder is open, click on the appropriate file. The control CRM will be inserted above the highlighted line.

Analyze a blank, the lowest standard, and a CRM (or a mid-range standard) every 10-12 samples. The CRM's are frozen in 30-ml bottles. Fill a 24 ml sample vial to the shoulder with CRM, cover with septum and cap. There is enough volume to sample the vial three times. When inserting the control sample in the sample table, assign the same vial position for each time. The autosampler is capable of returning to a particular vial site.

For the sample chosen to duplicate, fill the vial to the shoulder and cover. Indicate on the bench sheet at the appropriate location that the duplicate is to be inserted at that spot. If sample volume is not an issue, two sample vials can be used instead.

For the sample chosen to be spiked, withdraw 10.0 mls of sample using a volumetric pipet and add it to a sample vial. Then add 1.0 ml of the highest standard of the standard curve to the vial. Cover and cap, then gently shake to mix. Put the spiked sample in the proper location in the sample wheel. With the leftover sample, pour into another sample vial as the original sample. There is usually not enough volume to sample rinse the vial used for the spike or original sample.

Alternate duplicates and spikes every 10-12 samples.

End the run with blanks and standards, with the last control sample inserted between the bracketing standards.

Sample Table:

To create a new calibration file, refer to the User's Manual, Chapter 4.1 pp. 89-93, and follow the Calibration Curve Wizard Setup. Several curve templates are set up and are overwritten with new curve data each time they are used.

Create a method by clicking on File/New/Method and follow the Method Wizard Setup. Refer to the User's Manual Chapter 4.1 pp.94-96. A new method is created with each run.

Use drop down box to select type of analysis (i.e.: IC). Leave default Sample Name and Default Sample ID empty.

Enter the file name, and then click Next. (Example: dnr st martins041213)

The calibration curve is chosen on the next screen. Click Next again. Confirm the injection parameters to match the calibration curve. Click Next again.

Use default settings on the next page, and None for Pharmaceutical water testing on the last page.

Click Finish. The method is complete.

Editing the Sample Table:

Highlight the first line of the sample table to insert information. From the toolbar at the top, click on Insert.

Insert 3-4 conditioning blanks by clicking on Multiple Samples. Follow the wizard prompts. The water for conditioning blanks is the same as the reagent water in position 0.

Highlight the next available line to insert the calibration curve. Click on Insert/calibration curve. Choose the proper calibration file.

Highlight the next available line to insert multiple samples. Follow the wizard prompts. Leave the Sample Name and Sample ID blank.

Once the sample table has been set up, enter the sample names and IDs.

It is easiest to insert Control samples after the sample names and IDs are in place. Highlight the line below where the control sample is to be inserted. Click on Insert and select Control Sample. Choose the proper file.

When all sample and control information is entered into the table, enter the vial position numbers. Click on the carousel icon (looks like a birthday cake) in the sample table toolbar. The vial positions correspond to the numbered positions on the bench sheet. Be sure duplicate samples are numbered to match the original if sampling from the same vial. Click OK when finished.

Proof all entries and save the sample table. Click File/Save As to name the file.
Example: 2013_05_09_dnr st martins 042213

Highlight the first line of the sample table.

Click START. The Measurement Start Window is displayed. Click on the procedure to be performed when the analysis is complete. The instrument is kept running except over weekends. If no samples are to be run the next day, select Keep Running in case samples go off scale and need to be rerun. They can be inserted at the end of the sample table and run. Insert sample information and vial positions, then SAVE the file.

To open the Sample Window, click on the graph icon on the sample table to view peak information.

Accessing the data:

When the run has finished:

To save the file to another source (i.e. the shared network drive), (TOC-L-1) click File/Save As. TOC-L-2 does not communicate with the shared network drive in this capacity. With TOC-L-2, to save the standard curve, highlight the standard curve in the sample table. Select Print: Print highlighted. Print to XPS file. Name file as a curve file. The file is saved to the shared network drive. Open the file in the XPS Viewer. Print and save to the desktop.

To export data, click File/ASCII Export. Save the file in each form, Normal and Detailed. The Normal file contains only concentration information. The Detailed file includes all injection data. The ASCII files can now be opened in Excel. This works with both instruments.

Open TOC-L Sample Table on the desktop. Open the file from the shared network drive. Save the file to the desktop using the same file name.

To print the calibration curve information, highlight the calibration curve line in the sample table. Select Print on the toolbar, and Highlighted.

SHIMADZU DATA SHEET TIC curve		COLUMN RUN COUNTER		ANALYST: NLK OTHER:		
TODAYS DATE:		CRUISE:				
INSTRUMENT USED: TOC-L...1...2						
FILE NAME:						
SPIKE CONC.: 30 mg CO3/L						
VIAL/STD		VIAL/STD				
V0 DHOH		V4 15.0 CO3		INJECTION VOLUME: 800 uL		
V1 1.0 CO3		V6 30.0 CO3		other uL WORKING STDS MADE:		
V3 10.0 CO3						
VIAL/ID	SAMPLE ID	VIAL		SAMPLE ID	VIAL	SAMPLE ID
0 BLANK		22			48	
0 BLANK		23			49	
0 BLANK		24			50	
1 1.0 CO3		25			51	
2 5.0 CO3		26			52	
3 10.0 CO3		27			53	
4 15.0 CO3		28			54	
5 20.0 CO3		29				
6 30.0 CO3		30				COMMENTS
0 BLANK		31				
0 BLANK		32				
7 CRM		33				
8		34				
9		35				
10		36				
11		37				
12		38				
13		39				
14		40				
15		41				
16		42				Pre Run Checks
17		43				Mark All That Apply
18		44				Residue Removal (Daily) []
19		45				Flowline Wash (Daily) []
20		46				Regenerate Catalyst (as needed) []
21		47				New Column (as needed) []

UNIVERSITY OF MARYLAND CENTER FOR ENVIRONMENTAL SCIENCE
CHESAPEAKE BIOLOGICAL LABORATORY
NUTRIENT ANALYTICAL SERVICES LABORATORY
146 Williams St., Solomons MD 20688
<http://nasl.cbl.umces.edu/>

**Standard Operating Procedure for
Determination of Dissolved Inorganic Nitrite (NO₂) in Fresh/Estuarine/Coastal
Waters
(References EPA 353.2)**

**Revision 2017-1
Replaces Revision 2015
Effective April 26, 2017**

Revised by: _____ Date: _____

Reviewed by: _____ Date: _____

Laboratory Supervisor: _____ Date: _____

Changes affecting Revision 2015

Section 1.4: Changed concentration low end range to 0.0007
Section 1.7: Used references instead of conforms
Section 3.4: Changed the low end of analytical range to 0.00323
Section 3.5: Deleted preparation batch definition
Section 3.12.3: Changed CCV range to 18-23 samples
Entire Document: Changed deionized water to reagent water
Section 3.23: Changed blank matrix to matrix blank
Section 3.25: Added This is also referred to as MDL.
Section 3.26: Added This is also referred to as the Quantitation Limit
Section 3.35: Added Also referred to as CRM
Section 3.42: Added Also referred to as CRM
Section 5.1 Changed the word should to must, Changed CBL Business Manager to the CBL Associate Director of Administration and Facilities Maintenance
Section 5.4: Updated Chemical Safety Table (Table 1)
Section 6.1: Added Windows 7 operating system
Section 7.5: Changed Nitrite stock standard to be made in 500mL instead of 1L
Section 7.6: Changed secondary nitrite to be made in 200mL instead of 100mL
Section 7.9: Removed old description for Aquakem Cleaning Solution
Section 8.2: Added \leq sign for freezer temp
Section 8.2: Added the words sample cups
Section 9.2.1: Changed the initial demonstration of capability acronym to iDOC
Section 9.2.3: Changed the 10% to 3s
Section 9.2.4: Deleted from MDL description the change of operator or a new matrix is encountered, changed ambient water to natural water
Section 9.3.1: Deleted LRB above the MDL requires that the source of the problem must be identified and corrected before proceeding with analysis
Section 9.3.4: Added the words reagent blanks, deleted Set up an accuracy chart by using percent recovery since the concentration of the QCS/SRM varies
Section 9.3.5: Added ICV information to the CCV, Added See Appendix 1 for additional CCVs.
Section 9.3.6: Changed TV to the expected value
Section 9.3.7: Removed reagent blank description
Section 9.4: Changed % to read Percent
Section 9.7: Added Table 2
Section 10.1: Added 5-7 calibrators instead of 5, changed calibrating descriptions to match the Aquakem 250
Section 10.2: Added the coefficient of determination (Pearson's r value) for the calibration curve as well as the calculated concentration of each calibrator is reviewed. The calculated value of each calibrator must be within ten percent of the expected value. The coefficient of determination (Pearson's r value) for the calibration curve must be greater than 0.995.
Section 11: Added step by step descriptions for using Aquakem software
Section 14: Removed Method Performance

Determination of Dissolved Inorganic Nitrite (NO₂) in Fresh/Estuarine/Coastal Waters

1. SCOPE and APPLICATION

- 1.1 Nitrite reacts under acidic conditions with sulfanilamide to form a diazo compound that couples with N-1-naphthylethylenediamine dihydrochloride to quantitatively form a highly colored azo dye. The method is used to analyze all ranges of salinity.
- 1.2 A Method Detection Limit (MDL) of 0.0007 mg NO₂-N/L was determined using the Student's *t* value (3.14) times the standard deviation of seven replicates. If more than seven replicates are used to determine the MDL, refer to the Student's *t* test table for the appropriate n-1 value.
- 1.3 The Quantitation Limit for NO₂ was set at 0.0022 mg NO₂-N/L.
- 1.4 The method is suitable for NO₂ concentrations 0.0007 to 0.280 mg NO₂-N/L.
- 1.5 This procedure should be used by analysts experienced in the theory and application of aqueous inorganic analysis. Three months experience with an analyst, experienced in the analysis of nitrite in aqueous samples, is required.
- 1.6 This method can be used for all programs that require analysis of dissolved nitrite.
- 1.7 This procedure references to EPA Method 353.2 (1979).

2. SUMMARY

- 2.1 Filtered samples are diazotized with sulfanilamide and coupled with N-1-naphthylethylenediamine dihydrochloride to form a colored azo dye, yielding an intense pink color suitable for photometric measurement.

3. DEFINITIONS

- 3.1 Acceptance Criteria – Specified limits placed on characteristics of an item, process, or service defined in a requirement document. (ASQC)
- 3.2 Accuracy – The degree of agreement between an observed value and an accepted reference value. Accuracy includes a combination of random error (precision) and systematic error (bias) components which are due to sampling and analytical operations; a data quality indicator. (QAMS)
- 3.3 Aliquot – A discrete, measured, representative portion of a sample taken for analysis. (EPA QAD Glossary)
- 3.4 Analytical Range – 0.00323 to 0.280 mg NO₂-N/L. The overall analytical range is comprised of two distinct yet overlapping concentration ranges. A separate calibration is performed for each

range. These ranges include 0.00323 to 0.042 mg NO₂-N/L, and 0.028 to 0.28 mg NO₂-N/L. Two sub-ranges are utilized so that samples can be analyzed on the most appropriate scale possible.

- 3.5 Batch – Environmental samples, which are prepared and /or analyzed together with the same process and personnel, using the same lot(s) of reagents. An **analytical batch** is composed of prepared environmental samples (extracts, digestates, concentrates) and/or those samples not requiring preparation, which are analyzed together as a group using the same calibration curve or factor. An analytical batch can include samples originating from various environmental matrices and can exceed 20 samples. (NELAC/EPA)
- 3.6 Blank- A sample that has not been exposed to the analyzed sample stream in order to monitor contamination during sampling, transport, storage or analysis. The blank is subjected to the usual analytical and measurement process to establish a zero baseline or background value and is sometimes used to adjust or correct routine analytical results. (ASQC)
- 3.7 Calibrate- To determine, by measurement or comparison with a standard, the correct value of each scale reading on a device. The levels of the applied calibration standard should bracket the range of planned or expected sample measurements. (NELAC)
- 3.8 Calibration – The set of operations which establish, under specified conditions, the relationship between values indicated by a measuring device. The levels of the applied calibration standard should bracket the range of planned or expected sample measurements. (NELAC)
- 3.9 Calibration Blank – A volume of reagent water fortified with the same matrix as the calibration standards, without analyte added.
- 3.10 Calibration Curve – The graphical relationship between known values, such as concentrations, or a series of calibration standards and their analytical response. (NELAC)
- 3.11 Calibration Method – A defined technical procedure for performing a calibration. (NELAC)
- 3.12 Calibration Standard – A substance or reference material used to calibrate an instrument. (QAMS)
 - 3.12.1 Initial Calibration Standard (STD) – A series of standard solutions used to initially establish instrument calibration responses and develop calibration curves for individual target analytes.
 - 3.12.2 Initial Calibration Verification (ICV) – An individual standard, distinct from the Initial Calibration Standards (STD), analyzed initially, prior to any sample analysis, which verifies acceptability of the calibration curve or previously established calibration curve.
 - 3.12.3 Continuing Calibration Verification (CCV) – An individual standard, distinct from the Initial Calibration Standards (STD), analyzed after every 18-23 field sample analyses.

- 3.13 Certified Reference Material (CRM) – A reference material one or more of whose property values are certified by a technically valid procedure, accompanied by or traceable to a certificate or other documentation which is issued by a certifying body. (ISO 17025)
- 3.14 Corrective Action – Action taken to eliminate the causes of an existing nonconformity, defect or other undesirable situation in order to prevent recurrence. (ISO 8402)
- 3.15 Deficiency – An unauthorized deviation from acceptable procedures or practices. (ASQC)
- 3.16 Demonstration of Capability – A procedure to establish the ability of the analyst to generate acceptable accuracy. (NELAC)
- 3.17 Detection Limit – The lowest concentration or amount of the target analyte that can be determined to be different from zero by a single measurement at a stated degree of confidence.
- 3.18 Duplicate Analysis – The analyses of measurements of the variable of interest performed identically on two sub samples (aliquots) of the same sample. The results from duplicate analyses are used to evaluate analytical or measurement precision but not the precision of sampling, preservation or storage internal to the laboratory. (EPA-QAD)
- 3.19 External Standard (ES) – A pure analyte (Sodium Nitrite (NaNO_2)) that is measured in an experiment separate from the experiment used to measure the analyte(s) in the sample. The signal observed for a known quantity of the pure external standard is used to calibrate the instrument response for the corresponding analyte(s). The instrument response is used to calculate the concentrations of the analyte(s) in the unknown sample.
- 3.20 Field Duplicates (FD1 and FD2) – Two separate samples collected at the same time and place under identical circumstances and treated exactly the same throughout field and laboratory procedures. Analyses of FD1 and FD2 provide a measure of the precision associated with sample collection, preservation and storage, as well as with laboratory procedures.
- 3.21 Holding time – The maximum time that samples may be held prior to analysis and still be considered valid. (40 CFR Part 136) The time elapsed from the time of sampling to the time of extraction or analysis, as appropriate.
- 3.22 Laboratory Duplicates (LD1 and LD2) – Two aliquots of the same sample taken in the laboratory and analyzed separately with identical procedures. Analyses of LD1 and LD2 indicate precision associated with laboratory procedures, but not with sample collection, preservation, or storage procedures.
- 3.23 Laboratory Reagent Blank (LRB) – A matrix blank (i.e., reagent water) that is treated exactly as a sample including exposure to all glassware, equipment, solvents, and reagents that are used with other samples. The LRB is used to determine if method analytes or other

interferences are present in the laboratory environment, the reagents, or the instrument.

- 3.24 Laboratory Control Sample (LCS) – A sample matrix, free from the analytes of interest, spiked with verified known amounts of analytes from a source independent of the calibration standard or a material containing known and verified amounts of analytes. The LCS is generally used to establish intra-laboratory or analyst-specific precision and bias or to assess the performance of all or a portion of the measurement system. (NELAC)
- 3.25 Limit of Detection (LOD) – The lowest concentration level that can be determined by a single analysis and with a defined level of confidence to be statistically different from a blank. This is also referred to as MDL. (ACS)
- 3.26 Limit of Quantitation (LOQ) – The minimum levels, concentrations, or quantities of a target variable (target analyte) that can be reported with a specified degree of confidence. The LOQ is set at 3 to 10 times the LOD, depending on the degree of confidence desired. This is also referred to as the Quantitation Limit.
- 3.27 Linear Dynamic Range (LDR) – The absolute quantity over which the instrument response to an analyte is linear. This specification is also referred to as the Linear Calibration Range (LCR).
- 3.28 Material Safety Data Sheets (MSDS) – Written information provided by vendors concerning a chemical's toxicity, health hazards, physical properties, fire, and reactivity data including storage, spill, and handling precautions.
- 3.29 May – Denotes permitted action, but not required action. (NELAC)
- 3.30 Method Detection Limit (MDL) – The minimum concentration of an analyte that can be identified, measured, and reported with 99% confidence that the analyte concentration is greater than zero (Standard Methods).
- 3.31 Must – Denotes a requirement that must be met. (Random House College Dictionary)
- 3.32 Photometer – measures the absorbance of the solution in the cell in a multicell cuvette. Light passes from the lamp through the condensing lenses to the interference filter. The plane surface of the first condensing lens is coated with a material which reflects heat and infrared light. The filters are mounted on a filter wheel. There are 15 positions for filters. Each filter corresponds to a wavelength of interest. The 540 nm filter is specified by the test definition for nitrite. After passing through the filter the light is converted into a stream of light pulses by a chopper. Then the light is directed via a quartz fiber through a focusing lens and a slit to the beam divider. The beam divider divides the light into two parts. A specified portion is reflected to the reference detector, which monitors the light level fluctuations. The remaining major portion of the light beam goes through the liquid

in the cell to the signal detector, which measures the amount of light absorbed.

- 3.33 Precision – The degree to which a set of observations or measurements of the same property, obtained under similar conditions, conform to themselves; a data quality indicator. Precision is usually expressed as standard deviation, variance or range, in either absolute or relative terms. (NELAC)
- 3.34 Preservation – Refrigeration, freezing, and/or reagents added at the time of sample collection (or later) to maintain the chemical and or biological integrity of the sample.
- 3.35 Quality Control Sample (QCS) – A sample of analyte of known and certified concentration. The QCS is obtained from a source external to the laboratory and different from the source of calibration standards. It is used to check laboratory performance with externally prepared test materials. Also referred to as CRM.
- 3.36 Run Cycle – Typically a day of operation – the entire analytical sequence from sampling the first standard to the last sample of the day.
- 3.37 Sample Segment – Bar-coded metal tray that holds up to fourteen four milliliter auto analyzer vials containing samples or standards. The user identifies each vial in the operating software.
- 3.38 Sample Segment Holder – An automated temperature controlled carousel that contains up to six sample segments. This carousel spins in clockwise or counterclockwise manner to move the sample segments into position for analysis. This carousel format allows for continuous processing.
- 3.39 Sensitivity – The capability of a test method or instrument to discriminate between measurement responses representing different levels (concentrations) of a variable of interest.
- 3.40 Shall – Denotes a requirement that is mandatory whenever the criterion for conformance with the specification requires that there be no deviation. (ANSI)
- 3.41 Should – Denotes a guideline or recommendation whenever noncompliance with the specification is permissible. (ANSI)
- 3.42 Standard Reference Material (SRM) – Material which has been certified for specific analytes by a variety of analytical techniques and/or by numerous laboratories using similar analytical techniques. These may consist of pure chemicals, buffers, or compositional standards. The materials are used as an indication of the accuracy of a specific analytical technique. Also referred to as CRM.
- 3.43 Test Definition – A photometric test consisting of a user defined testing sequence, reagent additions, calibration standards, incubations and absorption results.
- 3.44 Test Flow – Functions to define the parameter for reagent and sample dispensing, dilution, incubation and measurement.



4 INTERFERENCES



- 4.1 Suspended matter in the sample will scatter light as it passes through the cuvette to the detector. High blank responses will result. The identified sample will be reanalyzed.
- 4.2 Blemishes in the cuvette, as result of the manufacturing process, will result in high blank responses. The identified sample will be reanalyzed.

5 SAFETY

- 5.1 Safety precautions must be taken when handling reagents, samples and equipment in the laboratory. Protective clothing including lab coats, safety glasses and enclosed shoes must be worn. In certain situations, it will be necessary to also use gloves and/or a face shield. If solutions come in contact with eyes, flush with water continuously for 15 minutes. If solutions come in contact with skin, wash thoroughly with soap and water. Contact Solomons Rescue Squad (911) if emergency treatment is needed and also inform CBL Associate Director of Administration and Facilities Maintenance of the incident. Contact the CBL Associate Director of Administration and Facilities Maintenance if additional treatment is required.
- 5.2 The toxicity or carcinogenicity of each reagent used in this procedure may not have been fully established. Each chemical should be regarded as a potential health hazard and exposure should be as low as reasonably achievable. Cautions are included for known hazardous materials and procedures.
- 5.3 Do not wear jewelry when troubleshooting electrical components. Even low voltage points are dangerous and can injure if allowed to short circuit.
- 5.4 The following hazard classifications are listed for the chemicals used in this procedure. Detailed information is provided on Material Safety Data Sheets (MSDS).

Table 1

Chemical	Health Hazard	Fire Hazard	Instability Hazard	Specific Hazard	
Hydrochloric acid	3	0	2	ACID, COR	
Sulfanilamide	1	1	0		
N-1-naphthylethylenedi amine dihydrochloride	1	0	0		
Sodium Nitrite	2	0	1	OXY	

Chloroform	3	0	0		
Clorox	3	0	0		

On a scale of 0 to 4 the substance is rated on four hazard categories: health, flammability, reactivity, and contact. (0 is non-hazardous and 4 is extremely hazardous)

HAZARD RATING

Health Hazard - Blue: 4 – deadly, 3 – extreme danger, 2 – hazardous, 1 – slightly hazardous, 0 – normal material

Fire Hazard - Red: Flash Points: 4 – below 73° F, 3 – below 100° F, 2 – below 200° F, 1 – above 200° F, 0 – will not burn

Instability Hazard - Yellow: 4 – may detonate, 3 – Shock and heat may detonate, 2 – violent chemical change, 1 – unstable is heated, 0 - stable

Specific Hazard - White: Acid = ACID, Alkali = ALK, Corrosive = COR, Oxidizer = OXY

6 EQUIPMENT AND SUPPLIES

- 6.1 Aquakem 250 multi-wavelength automated discrete photometric analyzer. Aquakem 250 control software operates on a computer running Microsoft Windows NT,XP, or 7 operating system.
- 6.2 Freezer, capable of maintaining $-20 \pm 5^{\circ} \text{C}$.
- 6.3 Lab ware – All reusable lab ware (glass, Teflon, plastic, etc) should be sufficiently clean for the task objectives. This laboratory cleans all lab ware related to this method with a 10% HCl (v/v) acid rinse.

7 REAGENTS AND STANDARDS

- 7.1 Purity of Water – Unless otherwise indicated, references to water shall be understood to mean reagent water conforming to Specification D 1193, Type I. Freshly prepared water should be used for making the standards intended for calibration. The detection limits of this method will be limited by the purity of the water and reagents used to make the standards.
- 7.2 Purity of Reagents – Reagent grade chemicals shall be used in all tests. Unless otherwise indicated, it is intended that all reagents shall conform to specifications of the Committee on Analytical Reagents of the American Chemical Society, where such specifications are available. Other grades may be used, provided it is first ascertained that the reagent is of sufficiently high purity to permit its use without compromising the accuracy of the determination.
- 7.3 Sulfanilamide solution

Hydrochloric acid (HCl), concentrated 25 mL

Sulfanilimide ($C_6H_8N_2 O_2S$) 2.5 g

In a 500 mL volumetric flask, add approximately 400 mL reagent water. Add 25 mL HCl to the reagent water. Add 2.5 g sulfanilamide and bring to volume. Write name of preparer, preparation date, reagent manufacturer, manufacturer's lot number in the Analytical Reagent log book. Transfer to brown poly bottle and store in refrigerator. Reagent is stable for one year.

7.4 N-1-naphthylethylenediamine dihydrochloride solution

N-1-naphthylethylenediamine dihydrochloride
($C_{12}H_{14}N_2 \cdot 2HCl$) 0.25 g

In a 500 mL volumetric flask, dissolve 0.25 g N-1-naphthylethylenediamine dihydrochloride in approximately 400 mL reagent water. Bring flask to volume. Transfer to a brown poly bottle and store in refrigerator. Write name of preparer, preparation date, reagent manufacturer, manufacturer's lot number in the Analytical Reagent log book. Reagent is stable for six months.

7.5 Nitrite Stock Standard, 5,000 μM –

Sodium nitrite ($NaNO_2$), primary standard grade, dried at 45°C

0.1725 g
Reagent water up to 500 mL

In a 500 mL volumetric flask, dissolve 0.1725 g of sodium nitrite in ~400 mL of reagent water. Dilute to 500 mL with reagent water (1 mL contains 5 $\mu moles$ N). Transfer to amber glass bottle. Add 1 mL of chloroform as a preservative and store at room temperature. Write name of preparer, preparation date, standard manufacturer, manufacturer lot number in the Analytical Standard log book. Make fresh every 6 months.

7.6 Secondary Nitrite Standard –

Stock Nitrite Standard 1.60 mL
Reagent water up to 200 mL

In a volumetric flask, dilute 1.60 mL of Stock Nitrite Standard to 200 mL with reagent water to yield a concentration of 40 μM NO_2^- -N/L (0.56 mg N/L). Write name of preparer, preparation date, Nitrite Stock Standard preparation date in the Analytical Standard log book. Store in refrigerator. Make fresh every month.

7.7 Working Nitrite Standard –

Secondary Nitrite Standard 7.50 mL

In a 100 mL volumetric flask, dilute 7.50 mL of Secondary Nitrite Standard to volume with reagent water to yield a concentration of 3.0 μM NO_2^- -N/L (0.042 mg N/L). Write name of preparer, preparation date, Secondary Nitrite Standard preparation date in the Analytical Standard log book. Store in refrigerator. Make fresh every month.

7.8 Working High Nitrite Standard –

Nitrite Stock Standard 0.40 mL

In a 100 mL volumetric flask, dilute 0.40 mL of Stock Nitrite Standard to volume with reagent water to yield a concentration of 20.0 μM $\text{NO}_2\text{-N/L}$ (0.28 mg N/L). Write name of preparer, preparation date, Nitrite Stock Standard preparation date in the Analytical Standard log book. Store in refrigerator. Make fresh every month.

7.9 Aquakem Cleaning Solution –

Clorox 55.0 mL

In a 100 mL volumetric flask, dilute 55.0 mL of Clorox to volume with reagent water to yield a concentration of 75% Clorox. Write name of preparer, preparation date, reagent manufacturer, manufacturer lot number in the Analytical Reagent log book. Reagent is stable for six months.

8 SAMPLE COLLECTION, PRESERVATION, AND STORAGE

8.1 Water collected for nitrite should be filtered through a Whatman GF/F glass fiber filter (nominal pore size 0.7 μm), or equivalent.

8.2 Water collected for nitrite should be frozen at $\leq -20^\circ\text{C}$. The AutoAnalyzer vial container (sample cups) should be clean and sample rinsed.

8.3 Frozen nitrite samples may be stored up to 28 days. It has been shown that frozen QCS samples up to a year old still fall well within the control limits.

8.4 Nitrite samples may be refrigerated at 4°C for no longer than one day.

9 QUALITY CONTROL

9.1 The laboratory is required to operate a formal quality control (QC) program. The minimum requirements of this program consist of an initial demonstration of laboratory capability and the continued analysis of laboratory instrument blanks and calibration standard material, analyzed as samples, as a continuing check on performance. The laboratory is required to maintain performance records that define the quality of data generated.

9.2 Initial Demonstration of Performance

9.2.1 The initial demonstration of capability (iDOC) – is used to characterize instrument performance (MDLs) and laboratory performance (analysis of QC samples) prior to the analyses conducted by this procedure.

9.2.2 Linear Dynamic Range – LDR (Linear Calibration Range) should be established for nitrite using appropriate five point calibration curve.

9.2.3 Quality Control Sample (QCS/SRM) – When using this procedure, a quality control sample is required to be analyzed at the beginning and end of the run, to verify data quality and acceptable instrument

performance. If the determined concentrations are not within $\pm 3s$ of the certified values, performance of the determinative step of the method is unacceptable. The source of the problem must be identified and corrected before either proceeding with the initial determination of MDLs or continuing with analyses.

- 9.2.4 Method Detection Limits (MDLs) – MDLs should be established for nitrite using a low level natural water sample. To determine the MDL values, analyze seven replicate aliquots of water. Perform all calculations defined in the procedure (Section 12) and report the concentration values in the appropriate units. Calculate the MDL as follows:

$$\text{MDL} = S t_{(n-1, 1-\alpha=0.99)}$$

Where,

S = Standard deviation of the replicate analyses.

n=number of replicates

$t_{(n-1, 1-\alpha=0.99)}$ = Student's *t* value for the 99% confidence level with n-1 degrees of freedom ($t=3.14$ for 7 replicates.)

- 9.2.5 MDLs shall be determined yearly and whenever there is a significant change in instrument response or a significant change in instrument configuration.

9.3 Assessing Laboratory Performance

- 9.3.1 Laboratory Reagent Blank (LRB) – The laboratory must analyze at least one LRB with each batch of samples. The LRB consists of reagent water treated the same as the samples. Analyte found in LRB indicates possible reagent or laboratory environment contamination. LRB data are used to assess and correct contamination from the laboratory environment.
- 9.3.2 Quality Control Sample (QCS)/ Standard Reference Material (SRM) – When using this procedure, a quality control sample is required to be analyzed at the beginning of the run and end of the run, to verify data quality and acceptable instrument performance. If the determined concentrations are not within $\pm 3s$ of the certified values, performance of the determinative step of the method is unacceptable. The source of the problem must be identified and corrected before either proceeding with the initial determination of MDLs or continuing with the analyses. The results of these QCS/SRM samples shall be used to determine batch acceptance.
- 9.3.3 The QCS are obtained from a source external to the laboratory and different from the source of calibration standards.
- 9.3.4 Control Charts – The Accuracy Control Chart for QCS/SRM samples and reagent blanks is constructed from the average and standard deviation of the 20 most recent QCS/SRM measurements. The

accuracy chart includes upper and lower warning levels ($WL=\pm 2s$) and upper and lower control levels ($CL=\pm 3s$). These values are derived from stated values of the QCS/SRM. The standard deviation (s) is specified relative to statistical confidence levels of 95% for WLs and 99% for CLs. Enter QCS/SRM results on the chart each time the sample is analyzed

- 9.3.5 Calibration Verification, Initial and Continuing (ICV/CCV) – Immediately following calibration (ICV) and following every 18-23 samples (CCV), one calibration verification of 2.0 μM $\text{NO}_2\text{-N/L}$ (0.028 mg N/L) NO_2CBL , 15 μM $\text{NO}_2\text{-N/L}$ (0.21 mg N/L) NO_2CBLHI , is analyzed to assess instrument performance. The CCVs are made from the same material as calibration standards (NaNO_2), and are to be within the expected value $\pm 3s$. Failure to meet the criteria requires correcting the problem, including reanalysis of any affected samples. If not enough sample exists, the data must be qualified if reported.

9.4 Assessing Analyte Recovery - Percent Recovery

- 9.4.1 Analyte recovery is assessed through percent recoveries of laboratory spikes of samples.

- 9.4.2 Percent Recovery = (Actual value/Expected value) X 100

9.5 Assessing Analyte Precision – Relative Percent Difference

- 9.5.1 Analyte replication is assessed through duplicate analyses of samples – Relative Percent Difference.

- 9.5.2 $\text{RPD} = (\text{Laboratory Duplicate Result } 1 - \text{Laboratory Duplicate Result } 2) / [(\text{Laboratory Duplicate Result } 1 + \text{Laboratory Duplicate Result } 2) / 2] \times 100$

9.6 Corrective Actions for Out of Control Data

- 9.6.1 Control limit – If one measurement exceeds Accuracy Control Chart CL, repeat the analysis immediately. If the repeat measurement is within the CL, continue analyses; if it exceeds the CL, discontinue analyses and correct the problem.

- 9.6.2 Warning limit – If two out of three successive points exceed Accuracy Control Chart WL, analyze another sample. If the next point is within WL, continue analyses; if the next point exceeds the WL, evaluate potential bias and correct the problem.

- 9.6.3 Trending – If seven successive Accuracy Control Chart measurements are on the same side of the central line, discontinue analyses and correct the problem.

- 9.6.4 When external QCS samples are out of control, correct the problem. Reanalyze the samples analyzed between the last in-control measurement and the out-of-control one.

- 9.6.5 When external CCV samples are out of control, correct the problem. Reanalyze the samples analyzed between the last in-control measurement and the out-of-control one.

9.7 General Operation - To assure optimal operation and analytical results, the Reagent Blank and CCV are tracked daily in the raw data file, copied to Reagent Blank and CCV Control Charts.

Table 2

QC Indicator	Acceptance/ Action Limits	Action	Frequency (Batch)
Correlation Coefficient	≥ 0.995	If <0.995 , evaluate data points of the calibration curve. If any data point is outside established limits, reject as outlier.	1 per batch if acceptable.
Quality Control Sample (QCS)/ Certified Reference Material (CRM)	$\pm 10\%$	If QCS value is outside $\pm 10\%$ of the target value reject the run, correct the problem and rerun samples.	Beginning of run and at end of run.
Initial Calibration Verification (ICV)	$\pm 10\%$	Recalibrate if outside acceptance limits.	Beginning of run following standard curve.
Continuing Calibration Verification (CCV)	$\pm 10\%$	If outside 10%, correct the problem. Rerun all samples following the last in-control CCV.	After every 18-23 samples.
Method Blank/Laboratory Reagent Blank (LRB)	\leq Method Quantitation Limit	If the LRB exceeds the quantitation limit, results are suspect. Rerun the LRB. If the concentration still exceeds the quantitation limit, reject or qualify the data, or raise the quantitation limit.	Following the ICV and after every 18-23 samples following the CCV.
Laboratory Fortified Sample Matrix Spike	$\pm 10\%$	If the recovery of any analyte falls outside the designated acceptance limits and the QCS is in control, the recovery problem is judged matrix induced. Repeat the LFM and if the sample results are again outside the acceptable recovery range, the sample should be reported with a "matrix induced bias" qualifier.	1/10 (spike OR duplicate)

Laboratory Duplicate	± 10%	If the RPD fails to meet the acceptance limits, the samples should be reanalyzed. If the RPD again fails to meet the acceptance limits, the sample must be reported with a qualifier identifying the sample analysis result as not having acceptable RPD for duplicate analysis.	1/10 (spike OR duplicate)
----------------------	-------	--	---------------------------

10 CALIBRATION AND STANDARDIZATION

10.1 Calibration – Daily calibration must be performed before sample analysis may begin. Five to seven point calibrations are used with each of the two sub-calibrations that cover the analytical range. Two working nitrite standards are used to produce the calibrators for each set of two calibration curves. The instrument performs serial dilutions of working standards to produce the five calibrators defined for each curve. The following outlines the preparation of the working standards and the following table describes the subsequent serial dilutions the instrument performs to make each standard for each of the two calibration curves.

Nitrite Working Standards:

NO₂ (NO₂CBL)

Working Standard 0.042 mg N/L (7.5 mL secondary standard to 100 mL)

Working CCV 0.028 mg N/L (5.0 mL secondary standard to 100 mL)

NO₂CBLHI

Working Standard 0.28 mg N/L (0.4 mL stock standard to 100 mL)

Working CCV 0.21 mg N/L (0.3 mL stock standard to 100 mL)

Table 3 Nitrite Calibrators:

Test Name	Working Standard	Dilution Factor	Concentration mg N/L
NO ₂ CBL	0.042 mg N/L	1+12	0.00323
	0.042 mg N/L	1+9	0.0042
	0.042 mg N/L	1+6	0.006
	0.042 mg N/L	1+4	0.0084
	0.042 mg N/L	1+2	0.014
	0.042 mg N/L	1+1	0.021
	0.042 mg N/L	1+0	0.042
NO ₂ CBLHI	0.28 mg N/L	1+9	0.028
	0.28 mg N/L	1+5	0.04667

	0.28 mg N/L	1+2	0.09333
	0.28 mg N/L	1+1	0.14
	0.28 mg N/L	1+0	0.28

10.2 The instrument software prepares a standard curve for each set of calibrators. A graph plotting measured absorbance against standard concentration is presented for review and approval. If acceptance criteria are not met the entire curve can be reanalyzed or individual standards can be reanalyzed. One standard value (original or reanalyzed) for each and every standard is incorporated in the curve. The coefficient of determination (Pearson's r value) for the calibration curve as well as the calculated concentration of each calibrator is reviewed. The calculated value of each calibrator must be within ten percent of the expected value. The coefficient of determination (Pearson's r value) for the calibration curve must be greater than 0.995.

11 PROCEDURE – DAILY OPERATIONS QUALITY CONTROL

- 11.1 Turn on computer. Computer will automatically initiate Konelab software. Once software is running, turn on instrument and allow connection between instrument and computer to complete.
- 11.2 Discard any water remaining in the water reservoir from the previous analytical run. Fill the water reservoir with fresh reagent water.
- 11.3 Remove samples from freezer to be analyzed. Allow samples to begin thawing. Begin daily bench sheet documentation.
- 11.4 Place cuvette waste box into cuvette waste sliding drawer.
- 11.5 Once water reservoir is full, use instrument software to click More, Instrument Actions, and Perform Water Wash.– complete at least five perform water wash cycles.
- 11.6 After performing water washes, clean the dispensing needle by performing test washes. Click More, Instrument Actions, More, Adjustment Program. Once in the Adjustment Program click, 4-Dispensing Unit, 1-Dispenser, 8-Test Wash. Perform 8 to 10 Test Washing. When complete, press “Q” to quit until you are able to bring up the Main Page.
- 11.7 Perform Start Up operations by clicking Start Up at the bottom of the Main Page.
- 11.8 Gather working standards and reagents from refrigerator during startup. Assess standards and reagents. Remake anything that has exceeded the time over which it is considered stable.
- 11.9 Once startup is complete, check the instrument water blanks by clicking More, Instrument Actions, More, Check Water Blank. If any of the instrument blanks are outside their predefined and software controlled limits, the user will be notified on the main menu page. User takes corrective action to return instrument functions to controlled limits.
- 11.10 Load reagents in specified position in reagent carousel and place in refrigerated reagent compartment. Reagent positions can be found by clicking reagents at the top of the main page.

- 11.11 Load working standards in a sample segment, identify the standards in their positions from the drop down menus at the individual segment positions, and load into instrument. . (Click Samples from the top of the Main Page, then click desired segment number.)
- 11.12 Select the methods to be calibrated by clicking Calibr./QC Selection on the bottom of the main page.. Click NO2CBL, and NO2CBLHI as the two methods to be calibrated, then click Calibrate at the bottom of the page. The two methods will now show as pending. Return to the main page.
- 11.13 Start instrument and calibration by clicking Page Up on the keyboard. This may also be a green button on the keyboard – See test flow below for stepwise instrument functions for the analysis of standards and samples.

Test Flow – Method of Analysis, Stepwise

- 145 µL sample to cuvette with mixing
 - Blank response measurement at 540 nm
 - 50 µL Sulfanilamide Reagent to cuvette with mixing
 - 50 µL N-1-naphthylethylenediamine dihydrochloride Reagent to cuvette with mixing
 - Incubation, 420 seconds, 37°C
 - End point absorbance measurement, 540 nm
 - Software processes absorbance value, blank response value and uses calibration curve to calculate analyte concentration (mg/L N as NO₂)
 - User is notified if any measured values used to calculate final concentration are outside preset limits. If so, analyst has options to accept result, rerun the sample or rerun the sample diluted to a user or software specified factor.
 - User is notified of each blank response value. Blank response >0.002 absorbance units indicates a scratched cuvette or turbid sample. If the blank response value exceeds 0.002 absorbance units, the analyst specifies that the sample is reanalyzed. If the blank response value of the reanalyzed sample is <0.002 absorbance units, the reanalyzed result is accepted. If the same concentration and blank response value >0.002 absorbance units is again obtained, the results are accepted.
- 11.14 Organize samples, reagent blanks, check standards and all quality control samples while instrument performs calibrations.
- 11.15 As calibration curves are produced by the instrument, review them for acceptability. The instrument software prepares a standard curve for each set of calibrators. A graph plotting measured absorbance against standard concentration is presented for review and approval. If acceptance criteria are not met, either the entire curve shall be reanalyzed or individual standards shall be reanalyzed, depending on the violation. One standard value (original or reanalyzed) for each and every calibrator is incorporated in the curve.
- 11.16 Once calibration curves are accepted, samples are loaded into the sample segments and loaded into the instrument for analysis. After the Reagent Blank, the first sample analyzed should be an ICV sample. There should be one ICV sample for each calibration curve, of a concentration close to the middle of each

- range. The following are recommended ICV samples for each curve: 0.028 mg N/L for NO₂CBL and 0.21 mg N/L for NO₂CBLHI.
- 11.17 Samples are loaded into the segments and analyzed. CCV samples (one for each of the two calibration ranges) follow every 18-23 samples. Standard Reference Material (SRM) samples, as well as Laboratory Reagent Blanks (LRB) are scattered throughout the analytical batch. Throughout the analytical batch, samples are chosen as laboratory duplicates and laboratory spikes to assess analyte precision and analyte recovery, respectively. The total number of duplicates and spikes performed will be equal or greater to ten percent of the total number of samples in the analytical batch.
- 11.18 As sample analysis is complete, results must be reviewed and accepted manually. If results fall outside acceptance limits, the sample should be reanalyzed. If sample result exceeds the highest standard of the highest calibration range, the samples can be automatically diluted by the instrument and reanalyzed. If the result is such that it will fall within a higher calibration range, it should be reanalyzed in the higher range. If the result is such that it will fall within a lower calibration range, it should be reanalyzed within the lower range.
- 11.19 Upon completion of all analysis, results are saved to a daily report file. Click Report on the bottom of the main page, More, Results To File, and select one row per result. The file is then named by the run date. The daily report file for analytical batch of July 1, 2017 would be named 070117. The file is converted to Microsoft Excel for data work up. Remaining samples are discarded.
- 11.20 All reagents are removed from the reagent chamber and returned to the refrigerator. Reagents that have exceeded their stability period are discarded.
- 11.21 Click on Stand By on the bottom of the main page and insert Aquakem Cleaning Solution into the instrument. This initiates shut down procedures. Daily files are cleared from the instrument software, the software by clicking More, Management, Clear Daily Files. The software is exited and the instrument is turned off. The computer is turned off.
- 11.22 The waste is flushed down the drain with copious amounts of tap water. The waste cuvette box is moved to the fume hood and covered.

12 DATA ANALYSIS AND CALCULATIONS

- 12.1 Upon completion of all analysis, results are saved to a daily report file. The file is named by the run date. The daily report file for analytical batch of July 1, 2017 would be named 070117. The file is converted to Microsoft Excel for data work up. The instrument software has calculated final sample concentration from the designated standard curve, correcting each concentration for associated blank response and also for any user or instrument specified dilution. Dilution by the instrument is noted by software as analysis ensues and, also, documented in the Excel data report file. The analyst examines each row of data. Results are eliminated that are outside the limits of the calibration range, or have an unrepeated blank response measurement greater than 0.002 absorbance units.

13 REFERENCES

- 13.1 USEPA. 1979. Method No. 353.2 *in* Methods for chemical analysis of water and wastes. United States Environmental Protection Agency, Office of Research and Development. Cincinnati, Ohio. Report No. EPA-600/4-79-020 March 1979. 460pp.
- 13.2 Frank, J. M., C.F. Zimmermann and C. W. Keefe (2006). Comparison of results from Konelab Aquakem 250 and existing nutrient analyzers. UMCES CBL Nutrient Analytical Services Laboratory, Dec. 2006.
- 13.3 Strickland, J.D.H. and T.R. Parsons. 1965. A Manual of Sea Water Analysis, 2nd ed. Fisheries Research Board of Canada, Ottawa.

UNIVERSITY OF MARYLAND CENTER FOR ENVIRONMENTAL SCIENCE
CHESAPEAKE BIOLOGICAL LABORATORY
NUTRIENT ANALYTICAL SERVICES LABORATORY
146 Williams St., Solomons MD 20688
<http://nasl.cbl.umces.edu/>

**Standard Operating Procedure for
Determination of Dissolved Inorganic Orthophosphate (PO₄) in
Fresh/Estuarine/Coastal Waters
(References EPA 365.1)**

**Revision 2017-2
Replaces Revision 2015
Effective April 26, 2017**

Revised by: _____ Date: _____

Reviewed by: _____ Date: _____

Laboratory Supervisor: _____ Date: _____

Changes affecting Revision 2015

Section 1.1: Changed from to form

Section 1.4: Lower concentration range changed from 0.0025 to 0.0006

Section 1.7: Conforms to EPA number to references EPA number

Section 3.4: Analytical range changed to 0.0035. Lower standard for two ranges changed to 0.0035 and 0.0169 respectfully

Section 3.5: Deleted preparation batch definition

Section 3.12.3: CCV range changed to 18-23 samples

Section 3.25: Added This is also referred to as MDL.

Section 3.26: Added This is also referred to as Quantitation Limit.

Section 3.35: Also referred to as CRM

Section 3.42: Also referred to as CRM

Section 4.3: Changed l to L for Liter

Section 5.1: Changed CBL Business Manager to Associate Director of Administration and Facilities Maintenance, changed shoes should be worn to shoes must be worn

Section 5.4: Safety data updated in Table 1

Section 6.1: Added Windows 7 operating system

Entire Document: Changed deionized water to reagent water

Section 7.3: Added let cool step

Section 7.8 Changed standard make up from 1L to 500 ml

Section 7.10: Removed the word regular

Section 7.13: Removed the old way of making Aquakem Cleaning Solution

Section 8.2: Added the words sample cups

Section 9.2.1: Changed orthophosphate to iDOC

Section 9.2.3: Changed 10% to be 3 standard deviations

Section 9.2.4: Changed estuarine waters to natural waters

Section 9.2.5: Added a significant change in instrument configuration

Section 9.3.1: Changed Nanopure to reagent water, Removed LRB above the lowest standard requires that the source of the problem must be identified and corrected before proceeding with analysis

Section 9.3.4: Changed samples to samples and reagent blank, deleted set up accuracy chart step for percent recovery

Section 9.3.5: Added ICV information with CCV, removed the word regular, changed TV to expected value

Section 9.4.6 (new number 9.3.6): Removed the section for Reagent Blank

Section 9.4: Changed % to Percent

Section 9.4.2: Changed % to Percent, Added Percent Recovery for each spiked sample should fall within 80-120%.

Section 9.7: Added Table 2

Section 10.1: Removed the word regular

Section 10.2: Corrected Persons to Pearsons, increased r value from 0.98 to 0.995

Section 11: Added instrument software steps throughout the entire section

Section 11.16: Changed usual to recommended

Section 13: Removed Method Performance section

Determination of Dissolved Inorganic Orthophosphate (PO₄) in Fresh/Estuarine/Coastal Waters

1. SCOPE and APPLICATION

- 1.1 Ammonium molybdate and potassium antimony tartrate react in an acid medium with dilute solutions of orthophosphate to form an antimony-phosphomolybdate complex which is reduced to an intensely blue-colored complex by ascorbic acid. Color is proportional to orthophosphate concentration. The method is used to analyze all ranges of salinity.
- 1.2 A Method Detection Limit (MDL) of 0.0006 mg PO₄-P/L was determined using the Student's *t* value (3.14) times the standard deviation of seven replicates. If more than seven replicates are used to determine the MDL, refer to the Student's *t* test table for the appropriate *n*-1 value.
- 1.3 The Quantitation Limit for PO₄-P was set at 0.0025 mg PO₄-P /L.
- 1.4 The method is suitable for PO₄-P concentrations 0.0006 to 1.488 mg PO₄-P/L.
- 1.5 This procedure should be used by analysts experienced in the theory and application of aqueous inorganic analysis. Three months experience with an analyst experienced in the analysis of orthophosphate in aqueous samples is required.
- 1.6 This method can be used for all programs that require analysis of dissolved orthophosphate.
- 1.7 This procedure references EPA Method 365.1 (1979).

2. SUMMARY

- 2.1 Filtered samples are mixed with a sulfuric acid-antimony-molybdate solution, and subsequently with an ascorbic acid solution, yielding an intense blue color suitable for photometric measurement.

3. DEFINITIONS

- 3.1 Acceptance Criteria – Specified limits placed on characteristics of an item, process, or service defined in a requirement document. (ASQC)
- 3.2 Accuracy – The degree of agreement between an observed value and an accepted reference value. Accuracy includes a combination of random error (precision) and systematic error (bias) components which are due to sampling and analytical operations; a data quality indicator. (QAMS)
- 3.3 Aliquot – A discrete, measured, representative portion of a sample taken for analysis. (EPA QAD Glossary)

- 3.4 Analytical Range – 0.0035 to 1.488 mg PO₄-P/L. The overall analytical range is comprised of three distinct yet overlapping concentration ranges. A separate calibration is performed for each range. These ranges include 0.0035 to 0.0558 mg PO₄-P/L, 0.0169 to 0.186 mg PO₄-P/L and 0.1488 to 1.488 mg PO₄-P/L. Three sub-ranges are utilized so that samples can be analyzed on the most appropriate scale possible.
- 3.5 Batch – Environmental samples, which are prepared and /or analyzed together with the same process and personnel, using the same lot(s) of reagents. An **analytical batch** is composed of prepared environmental samples (extracts, digestates, concentrates) and/or those samples not requiring preparation, which are analyzed together as a group using the same calibration curve or factor. An analytical batch can include samples originating from various environmental matrices and can exceed 20 samples. (NELAC/EPA)
- 3.6 Blank- A sample that has not been exposed to the analyzed sample stream in order to monitor contamination during sampling, transport, storage or analysis. The blank is subjected to the usual analytical and measurement process to establish a zero baseline or background value and is sometimes used to adjust or correct routine analytical results. (ASQC)
- 3.7 Calibrate- To determine, by measurement or comparison with a standard, the correct value of each scale reading on a device. The levels of the applied calibration standard should bracket the range of planned or expected sample measurements. (NELAC)
- 3.8 Calibration – The set of operations which establish, under specified conditions, the relationship between values indicated by a measuring device. The levels of the applied calibration standard should bracket the range of planned or expected sample measurements. (NELAC)
- 3.9 Calibration Blank – A volume of reagent water fortified with the same matrix as the calibration standards, without analyte added.
- 3.10 Calibration Curve – The graphical relationship between known values, such as concentrations, or a series of calibration standards and their analytical response. (NELAC)
- 3.11 Calibration Method – A defined technical procedure for performing a calibration. (NELAC)
- 3.12 Calibration Standard – A substance or reference material used to calibrate an instrument. (QAMS)
- 3.12.1 Initial Calibration Standard (STD) – A series of standard solutions used to initially establish instrument calibration responses and develop calibration curves for individual target analytes.
- 3.12.2 Initial Calibration Verification (ICV) – An individual standard, distinct from the Initial Calibration Standards (STD), analyzed initially, prior to any sample analysis,

which verifies acceptability of the calibration curve or previously established calibration curve.

- 3.12.3 Continuing Calibration Verification (CCV) – An individual standard, distinct from the Initial Calibration Standards (STD), analyzed after every 18-23 field sample analyses.
- 3.13 Certified Reference Material – A reference material one or more of whose property values are certified by a technically valid procedure, accompanied by or traceable to a certificate or other documentation which is issued by a certifying body. (ISO 17025)
- 3.14 Corrective Action – Action taken to eliminate the causes of an existing nonconformity, defect or other undesirable situation in order to prevent recurrence. (ISO 8402)
- 3.15 Deficiency – An unauthorized deviation from acceptable procedures or practices. (ASQC)
- 3.16 Demonstration of Capability – A procedure to establish the ability of the analyst to generate acceptable accuracy. (NELAC)
- 3.17 Detection Limit – The lowest concentration or amount of the target analyte that can be determined to be different from zero by a single measurement at a stated degree of confidence.
- 3.18 Duplicate Analysis – The analyses of measurements of the variable of interest performed identically on two sub samples (aliquots) of the same sample. The results from duplicate analyses are used to evaluate analytical or measurement precision but not the precision of sampling, preservation or storage internal to the laboratory. (EPA-QAD)
- 3.19 External Standard (ES) – A pure analyte (Potassium dihydrogen phosphate (KH_2PO_4)) that is measured in an experiment separate from the experiment used to measure the analyte(s) in the sample. The signal observed for a known quantity of the pure external standard is used to calibrate the instrument response for the corresponding analyte(s). The instrument response is used to calculate the concentrations of the analyte(s) in the unknown sample.
- 3.20 Field Duplicates (FD1 and FD2) – Two separate samples collected at the same time and place under identical circumstances and treated exactly the same throughout field and laboratory procedures. Analyses of FD1 and FD2 provide a measure of the precision associated with sample collection, preservation and storage, as well as with laboratory procedures.
- 3.21 Holding time – The maximum time that samples may be held prior to analysis and still be considered valid. (40 CFR Part 136) The time elapsed from the time of sampling to the time of extraction or analysis, as appropriate.
- 3.22 Laboratory Duplicates (LD1 and LD2) – Two aliquots of the same sample taken in the laboratory and analyzed separately with identical procedures. Analyses of LD1 and LD2 indicate precision associated with laboratory procedures, but not with sample collection, preservation, or storage procedures.

- 3.23 Laboratory Reagent Blank (LRB) – A matrix blank (i.e., reagent water) that is treated exactly as a sample including exposure to all glassware, equipment, solvents, and reagents that are used with other samples. The LRB is used to determine if method analytes or other interferences are present in the laboratory environment, the reagents, or the instrument.
- 3.24 Laboratory Control Sample (LCS) – A sample matrix, free from the analytes of interest, spiked with verified known amounts of analytes from a source independent of the calibration standard or a material containing known and verified amounts of analytes. The LCS is generally used to establish intra-laboratory or analyst-specific precision and bias or to assess the performance of all or a portion of the measurement system. (NELAC)
- 3.25 Limit of Detection (LOD) – The lowest concentration level that can be determined by a single analysis and with a defined level of confidence to be statistically different from a blank. This is also referred to as MDL. (ACS)
- 3.26 Limit of Quantitation (LOQ) – The minimum levels, concentrations, or quantities of a target variable (target analyte) that can be reported with a specified degree of confidence. The LOQ is set at 3 to 10 times the LOD, depending on the degree of confidence desired. This is also referred to as the Quantitation Limit.
- 3.27 Linear Dynamic Range (LDR) – The absolute quantity over which the instrument response to an analyte is linear. This specification is also referred to as the Linear Calibration Range (LCR).
- 3.28 Material Safety Data Sheets (MSDS) – Written information provided by vendors concerning a chemical’s toxicity, health hazards, physical properties, fire, and reactivity data including storage, spill, and handling precautions.
- 3.29 May – Denotes permitted action, but not required action. (NELAC)
- 3.30 Method Detection Limit (MDL) – The minimum concentration of an analyte that can be identified, measured, and reported with 99% confidence that the analyte concentration is greater than zero (Standard Methods).
- 3.31 Must – Denotes a requirement that must be met. (Random House College Dictionary)
- 3.32 Photometer – measures the absorbance of the solution in the cell in a multicell cuvette. Light passes from the lamp through the condensing lenses to the interference filter. The plane surface of the first condensing lens is coated with a material which reflects heat and infrared light. The filters are mounted on a filter wheel. There are 15 positions for filters. Each filter corresponds to a wavelength of interest. The 880 nm filter is specified by the test definition for orthophosphate. After passing through the filter the light is converted into a stream of light pulses by a chopper. Then the light is directed

via a quartz fiber through a focusing lens and a slit to the beam divider. The beam divider divides the light into two parts. A specified portion is reflected to the reference detector, which monitors the light level fluctuations. The remaining major portion of the light beam goes through the liquid in the cell to the signal detector, which measures the amount of light absorbed.

- 3.33 Precision – The degree to which a set of observations or measurements of the same property, obtained under similar conditions, conform to themselves; a data quality indicator. Precision is usually expressed as standard deviation, variance or range, in either absolute or relative terms. (NELAC)
- 3.34 Preservation – Refrigeration, freezing, and/or reagents added at the time of sample collection (or later) to maintain the chemical and or biological integrity of the sample.
- 3.35 Quality Control Sample (QCS) – A sample of analyte of known and certified concentration. The QCS is obtained from a source external to the laboratory and different from the source of calibration standards. It is used to check laboratory performance with externally prepared test materials. Also referred to as CRM.
- 3.36 Run Cycle – Typically a day of operation – the entire analytical sequence from sampling the first standard to the last sample of the day.
- 3.37 Sample Segment – Bar-coded metal tray that holds up to fourteen four milliliter auto analyzer vials containing samples or standards. The user identifies each vial in the operating software.
- 3.38 Sample Segment Holder – An automated, temperature controlled carousel that contains up to six sample segments. This carousel spins in clockwise or counterclockwise manner to move the sample segments into position for analysis. This carousel format allows for continuous processing.
- 3.39 Sensitivity – The capability of a test method or instrument to discriminate between measurement responses representing different levels (concentrations) of a variable of interest.
- 3.40 Shall – Denotes a requirement that is mandatory whenever the criterion for conformance with the specification requires that there be no deviation. (ANSI)
- 3.41 Should – Denotes a guideline or recommendation whenever noncompliance with the specification is permissible. (ANSI)
- 3.42 Standard Reference Material (SRM) – Material which has been certified for specific analytes by a variety of analytical techniques and/or by numerous laboratories using similar analytical techniques. These may consist of pure chemicals, buffers, or compositional standards. The materials are used as an indication of the accuracy of a specific analytical technique. Also referred to as CRM.
- 3.43 Test Definition – A photometric test consisting of a user defined testing sequence, reagent additions, calibration standards, incubations and absorption results.

3.44 Test Flow – Functions to define the parameter for reagent and sample dispensing, dilution, incubation and measurement.











4 INTERFERENCES

- 4.1 Suspended matter in the sample will scatter light as it passes through the cuvette to the detector. High blank responses will result. The identified sample will be reanalyzed.
- 4.2 Blemishes in the cuvette, as result of the manufacturing process, will result in high blank responses. The identified sample will be reanalyzed.
- 4.3 As much as 50 mg Fe/L, 10 mg Cu/L and 10 mg SiO₂/L can be tolerated. High silica concentrations cause positive interference.

5 SAFETY

- 5.1 Safety precautions must be taken when handling reagents, samples and equipment in the laboratory. Protective clothing including lab coats, safety glasses and enclosed shoes must be worn. In certain situations, it will be necessary to also use gloves and/or a face shield. If solutions come in contact with eyes, flush with water continuously for 15 minutes. If solutions come in contact with skin, wash thoroughly with soap and water. Contact Solomons Rescue Squad (911) if emergency treatment is needed and also inform the CBL Associate Director of Administration and Facilities Maintenance of the incident. Contact the CBL Associate Director of Administration and Facilities Maintenance if additional treatment is required.
- 5.2 The toxicity or carcinogenicity of each reagent used in this procedure may not have been fully established. Each chemical should be regarded as a potential health hazard and exposure should be as low as reasonably achievable. Cautions are included for known hazardous materials and procedures.
- 5.3 Do not wear jewelry when troubleshooting electrical components. Even low voltage points are dangerous and can injure if allowed to short circuit.
- 5.4 The following hazard classifications are listed for the chemicals used in this procedure. Detailed information is provided on Material Safety Data Sheets (MSDS).

Table 1

Chemical	Health Hazard	Fire Hazard	Instability Hazard	Specific Hazard	
Sulfuric acid	4	0	2	ACID, COR	
Ammonium molybdate	4	0	1	Irritant	 
Potassium antimonyl tartrate hemihydrate	2	0	0		
Ascorbic Acid	1	0	0	ACID	
Potassium dihydrogen phosphate	2	0	0		
Chloroform	3	0	0		 
Sodium hydroxide	3	0	1	ALK, COR	 
Clorox	3	0	0		

On a scale of 0 to 4 the substance is rated on four hazard categories: health, flammability, reactivity, and contact. (0 is non-hazardous and 4 is extremely hazardous)

HAZARD RATING

Health Hazard - Blue: 4 – deadly, 3 – extreme danger, 2 – hazardous, 1 – slightly hazardous, 0 – normal material

Fire Hazard - Red: Flash Points: 4 – below 73° F, 3 – below 100° F, 2 – below 200° F, 1 – above 200° F, 0 – will not burn

Instability Hazard - Yellow: 4 – may detonate, 3 – Shock and heat may detonate, 2 – violent chemical change, 1 – unstable is heated, 0 - stable

Specific Hazard - White: Acid = ACID, Alkali = ALK, Corrosive = COR, Oxidizer = OXY

6 EQUIPMENT AND SUPPLIES

- 6.1 Aquakem 250 multi-wavelength automated discrete photometric analyzer.
Aquakem 250 control software operates on a computer running Microsoft Windows NT,XP or 7 operating system.
- 6.2 Freezer, capable of maintaining $-20 \pm 5^{\circ}$ C.
- 6.3 Lab ware – All reusable lab ware (glass, Teflon, plastic, etc) should be sufficiently clean for the task objectives. This laboratory cleans all lab ware related to this method with a 10% HCl (v/v) acid rinse. This laboratory cleans all lab ware that has held solutions containing ammonium molybdate with 10% NaOH (w/v) rinse.

7 REAGENTS AND STANDARDS

- 7.1 Purity of Water – Unless otherwise indicated, references to water shall be understood to mean reagent water conforming to Specification D 1193, Type I. Freshly prepared water should be used for making the standards intended for calibration. The detection limits of this method will be limited by the purity of the water and reagents used to make the standards.
- 7.2 Purity of Reagents – Reagent grade chemicals shall be used in all tests. Unless otherwise indicated, it is intended that all reagents shall conform to specifications of the Committee on Analytical Reagents of the American Chemical Society, where such specifications are available. Other grades may be used, provided it is first ascertained that the reagent is of sufficiently high purity to permit its use without compromising the accuracy of the determination.

7.3 9.8 N Sulfuric acid

Sulfuric acid (concentrated) 54.4 mL

In a 200 mL volumetric flask add approximately 120 mL reagent water. Add 54.4 mL H₂SO₄ to the reagent water, let cool, and bring to volume. Write name of preparer, preparation date, reagent manufacturer, manufacturer's lot number in the Analytical Reagent log book. Store the flask at room temperature. Reagent is stable for one year.

7.4 Ammonium molybdate solution

Ammonium molybdate 8.0 g

In a 100 mL plastic volumetric flask dissolve, with immediate inversion, 8.0 g Ammonium molybdate, in approximately 90 mL reagent water. Bring flask to volume. Store flask in dark at room temperature. Write name of preparer, preparation date, reagent manufacturer, manufacturer's lot number in the Analytical Reagent log book. Reagent is stable for one month. Discard if white precipitate appears in flask or on threads of cap.

7.5 Potassium antimonyl tartrate solution

Potassium antimonyl tartrate 0.6 g

In a 100 mL plastic volumetric flask dissolve 0.6 g Potassium antimonyl tartrate hemihydrate in approximately 90 mL reagent water. Bring flask to volume. Store flask at room temperature. Write name of preparer,

preparation date, reagent manufacturer, manufacturer's lot number in the Analytical Reagent log book. Reagent is stable for one year.

7.6 Ascorbic acid solution

Ascorbic acid	3.6 g
---------------	-------

In a 100 mL plastic volumetric flask dissolve 3.6g Ascorbic acid in approximately 90 mL reagent water. Bring flask to volume. Store flask in refrigerator. Write name of preparer, preparation date, reagent manufacturer, manufacturer's lot number in the Analytical Reagent log book. Reagent is stable for two months.

7.7 Triple Reagent -

9.8 N Sulfuric acid	40 mL
Ammonium molybdate solution	12 mL
Potassium antimonyl tartrate solution	4.0 mL

Add 40 mL 9.8 N Sulfuric acid to a 60 mL reagent container. Carefully add 12 mL Ammonium molybdate solution to the reagent container. Carefully add 4.0 mL Potassium antimonyl tartrate solution to the reagent container. Cap. Invert six times to mix. Store container in refrigerator. Write name of preparer, preparation date, constituent solutions' preparation dates in the Analytical Reagent log book. Reagent is stable for two weeks.

7.8 Orthophosphate Stock Standard, 12,000 μM –

Potassium dihydrogen phosphate (KH_2PO_4), primary standard grade, dried at 45°C	0.816 g
--	---------

In a 500 mL volumetric flask, dissolve 0.816 g of potassium dihydrogen phosphate in approximately 400 mL reagent water. Bring flask to volume with reagent water (1 mL contains 12 $\mu\text{moles P}$). Add 1 mL chloroform as a preservative. Transfer to a brown bottle and store in refrigerator. Write name of preparer, preparation date, standard manufacturer, manufacturer lot number in the Analytical Standard log book. Make fresh every 6 months.

7.9 Secondary Orthophosphate Standard –

Stock Orthophosphate standard	1.0 mL
-------------------------------	--------

In a 100 mL volumetric flask, dilute 1.0 mL of Stock Orthophosphate Standard to volume with reagent water to yield a concentration of 120 $\mu\text{M PO}_4\text{-P/L}$ (1 mL contains 1.2 $\mu\text{moles P}$). Store flask in refrigerator. Write name of preparer, preparation date, Stock Standard preparation date in the Analytical Standard log book. Make fresh every month.

7.10 Working Orthophosphate Standard –

Secondary Orthophosphate Standard	1.50 mL
-----------------------------------	---------

In a 100 mL volumetric flask, dilute 1.50 mL of Secondary Orthophosphate Standard to volume with reagent water to yield a concentration of 1.8 $\mu\text{M PO}_4\text{-P/L}$ (0.0558 mg P/L). Store flask in refrigerator. Write name of preparer, preparation date, Secondary Orthophosphate Standard preparation date in the Analytical Standard log book. Make fresh every month.

7.11 Working High Orthophosphate Standard –

- Secondary Orthophosphate Standard 6.00 mL
In a 100 mL volumetric flask, dilute 6.00 mL of Secondary Orthophosphate Standard to volume with reagent water to yield a concentration of 6.0 μM $\text{PO}_4\text{-P/L}$ (0.186 mg P/L). Store flask in refrigerator. Write name of preparer, preparation date, Secondary Orthophosphate Standard preparation date in the Analytical Standard log book. Make fresh every month.
- 7.12 Working Extra High Orthophosphate Standard –
Stock Orthophosphate Standard 0.40 mL
In a 100 mL volumetric flask, dilute 0.40 mL of Stock Orthophosphate Standard to volume with reagent water to yield a concentration of 48 μM $\text{PO}_4\text{-P/L}$ (1.488 mg P/L). Store flask in refrigerator. Write name of preparer, preparation date, Stock Orthophosphate Standard preparation date in the Analytical Standard log book. Make fresh every month.
- 7.13 Aquakem Cleaning Solution –
Clorox 55.0 mL
In a 100 mL volumetric flask, dilute 55.0 mL of Clorox to volume with 45 mL reagent water to yield a concentration of 75% Clorox. Write name of preparer, preparation date, reagent manufacturer, manufacturer lot number in the Analytical Reagent log book. Reagent is stable for six months.

8 SAMPLE COLLECTION, PRESERVATION, AND STORAGE

- 8.1 Water collected for orthophosphate should be filtered through a Whatman GF/F glass fiber filter (nominal pore size 0.7 μm), or equivalent.
- 8.2 Water collected for orthophosphate should be frozen at $\leq -20^\circ\text{C}$. The AutoAnalyzer vial container (sample cups) should be clean and sample rinsed.
- 8.3 Frozen orthophosphate samples may be stored up to 28 days. It has been shown that frozen QCS samples up to a year old still fall well within the control limits.
- 8.4 Orthophosphate samples may be refrigerated at 4°C for no longer than one day.

9 QUALITY CONTROL

- 9.1 The laboratory is required to operate a formal quality control (QC) program. The minimum requirements of this program consist of an initial demonstration of laboratory capability and the continued analysis of laboratory instrument blanks and calibration standard material, analyzed as samples, as a continuing check on performance. The laboratory is required to maintain performance records that define the quality of data generated.
- 9.2 Initial Demonstration of Performance

- 9.2.1 The initial demonstration of capability (iDOC) – is used to characterize instrument performance (MDLs) and laboratory performance (analysis of QC samples) prior to the analyses conducted by this procedure.
- 9.2.2 Linear Dynamic Range – LDR (Linear Calibration Range) should be established for orthophosphate using appropriate seven point calibration curve.
- 9.2.3 Quality Control Sample (QCS/SRM) – When using this procedure, a quality control sample is required to be analyzed at the beginning and end of the run, to verify data quality and acceptable instrument performance. If the determined concentrations are not within $\pm 3s$ of the certified values, performance of the determinative step of the method is unacceptable. The source of the problem must be identified and corrected before either proceeding with the initial determination of MDLs or continuing with analyses.

9.2.4 Method Detection Limits (MDLs) – MDLs should be established for orthophosphate using a low level natural water sample, typically three to five times higher than the estimated MDL. To determine the MDL values, analyze seven replicate aliquots of water and process through the entire analytical procedure. Perform all calculations defined in the procedure (Section 12) and report the concentration values in the appropriate units. Calculate the MDL as follows:

$$MDL = St_{(n-1, 1-\alpha=0.99)}$$

Where,

S = Standard deviation of the replicate analyses.

n=number of replicates

$t_{(n-1, 1-\alpha=0.99)}$ = Student's *t* value for the 99% confidence level with n-1 degrees of freedom ($t=3.14$ for 7 replicates.)

9.2.5 MDLs should be determined annually, whenever there is a significant change in instrumental response or a significant change in instrument configuration, .

9.3 Assessing Laboratory Performance

- 9.3.1 Laboratory Reagent Blank (LRB) – The laboratory must analyze at least one LRB with each batch of samples. The LRB consists of reagent water treated the same as the samples. Analyte found in LRB indicates possible reagent or laboratory environment contamination. LRB data are used to assess and correct contamination from the laboratory environment.
- 9.3.2 Quality Control Sample (QCS)/ Standard Reference Material (SRM) – When using this procedure, a quality control sample is required to be analyzed at the beginning of the run and end of the run, to verify data quality and acceptable instrument performance. If the determined concentrations are not within $\pm 3s$ of the certified values, performance

of the determinative step of the method is unacceptable. The source of the problem must be identified and corrected before either proceeding with the initial determination of MDLs or continuing with the analyses. The results of these QCS/SRM samples shall be used to determine batch acceptance.

- 9.3.3 The QCS are obtained from a source external to the laboratory and different from the source of calibration standards.
- 9.3.4 Control Charts – The Accuracy Control Chart for QCS/SRM samples and reagent blanks is constructed from the average and standard deviation of the 20 most recent QCS/SRM measurements. The accuracy chart includes upper and lower warning levels ($WL=\pm 2s$) and upper and lower control levels ($CL=\pm 3s$). These values are derived from stated values of the QCS/SRM. The standard deviation (s) is specified relative to statistical confidence levels of 95% for WLs and 99% for CLs. Enter QCS/SRM results on the chart each time the sample is analyzed
- 9.3.5 Calibration Verification, Initial and Continuing (ICV/CCV) – Immediately following calibration (ICV) and following every 18-23 samples (CCV), one calibration verification of 1.2 μM $\text{PO}_4\text{-P/L}$ (0.0372 mg P/L) $\text{PO}_4\text{CBL2}$, 4 μM $\text{PO}_4\text{-P/L}$ (0.1488 mg P/L) $\text{PO}_4\text{ HIGH}$, 36 μM $\text{PO}_4\text{-P/L}$ (1.116 mg P/L) $\text{PO}_4\text{ XHIGH}$ is analyzed to assess instrument performance. The CCVs are made from the same material as calibration standards (KH_2PO_4), and are to be within the expected value $\pm 3s$. Failure to meet the criteria requires correcting the problem, including reanalysis of any affected samples. If not enough sample exists, the data must be qualified if reported.

9.4 Assessing Analyte Recovery - Percent Recovery

- 9.4.1 Analyte recovery is assessed through percent recoveries of laboratory spikes of samples.
- 9.4.2 Percent Recovery = (Actual value/Expected value) X 100

9.5 Assessing Analyte Precision – Relative Percent Difference

- 9.5.1 Analyte replication is assessed through duplicate analyses of samples – Relative Percent Difference.
- 9.5.2 $\text{RPD} = (\text{Laboratory Duplicate Result 1} - \text{Laboratory Duplicate Result 2}) / [(\text{Laboratory Duplicate Result 1} + \text{Laboratory Duplicate Result 2}) / 2] \times 100$

9.6 Corrective Actions for Out of Control Data

- 9.6.1 Control limit – If one measurement exceeds Accuracy Control Chart CL, repeat the analysis immediately. If the repeat measurement is within the CL, continue analyses; if it exceeds the CL, discontinue analyses and correct the problem.
- 9.6.2 Warning limit – If two out of three successive points exceed Accuracy Control Chart WL, analyze another sample. If the next point is within

WL, continue analyses; if the next point exceeds the WL, evaluate potential bias and correct the problem.

- 9.6.3 Trending – If seven successive Accuracy Control Chart measurements are on the same side of the central line, discontinue analyses and correct the problem.
- 9.6.4 When external QCS samples are out of control, correct the problem. Reanalyze the samples analyzed between the last in-control measurement and the out-of-control one.
- 9.6.5 When external CCV samples are out of control, correct the problem. Reanalyze the samples analyzed between the last in-control measurement and the out-of-control one.

9.7 General Operation - To assure optimal operation and analytical results, the Reagent Blank and CCV are tracked daily in the raw data file, copied to Reagent Blank and CCV Control Charts.

Table 2

QC Indicator	Acceptance/ Action Limits	Action	Frequency (Batch)
Correlation Coefficient	≥ 0.995	If <0.995 , evaluate data points of the calibration curve. If any data point is outside established limits, reject as outlier.	1 per batch if acceptable.
Quality Control Sample (QCS)/ Certified Reference Material (CRM)	$\pm 10\%$	If QCS value is outside $\pm 10\%$ of the target value reject the run, correct the problem and rerun samples.	Beginning of run and at end of run.
Initial Calibration Verification (ICV)	$\pm 10\%$	Recalibrate if outside acceptance limits.	Beginning of run following standard curve.
Continuing Calibration Verification (CCV)	$\pm 10\%$	If outside 10%, correct the problem. Rerun all samples following the last in-control CCV.	After every 18-23 samples.
Method Blank/Laboratory Reagent Blank (LRB)	\leq Method Quantitation Limit	If the LRB exceeds the quantitation limit, results are suspect. Rerun the LRB. If the concentration still exceeds the quantitation limit, reject or qualify the data, or raise the quantitation limit.	Following the ICV and after every 18-23 samples following the CCV.

Laboratory Fortified Sample Matrix Spike	± 10%	If the recovery of any analyte falls outside the designated acceptance limits and the QCS is in control, the recovery problem is judged matrix induced. Repeat the LFM and if the sample results are again outside the acceptable recovery range, the sample should be reported with a “matrix induced bias” qualifier.	1/10 (spike OR duplicate)
Laboratory Duplicate	± 10%	If the RPD fails to meet the acceptance limits, the samples should be reanalyzed. If the RPD again fails to meet the acceptance limits, the sample must be reported with a qualifier identifying the sample analysis result as not having acceptable RPD for duplicate analysis.	1/10 (spike OR duplicate)

10 CALIBRATION AND STANDARDIZATION

10.1 Calibration – Daily calibration must be performed before sample analysis may begin. Six or seven point calibrations are used with each of the three sub-calibrations that cover the analytical range. Three working orthophosphate standards are used to produce the calibrators for each set of three calibration curves. The instrument performs serial dilutions of working standards to produce the six or seven calibrators defined for each curve. The following outlines the preparation of the working standards and the following table describes the subsequent serial dilutions the instrument performs to make each standard for each of the three calibration curves.

Orthophosphate Working Standards:

PO4 (PO4CBL2)

Working Standard 0.0558 mg P/L (1.5 mL secondary standard to 100 mL)

Working CCV 0.0372 mg P/L (1.0 mL secondary standard to 100 mL)

PO4HIGH

Working Standard 0.186 mg P/L (6.0 mL secondary standard to 100 mL)

Working CCV 0.1488 mg P/L (4.0 mL secondary standard to 100 mL)

Extra High PO4 (PPCBL)

Working Standard 1.488 mg P/L (0.4 mL stock to 100 mL)

Working CCV 1.116 mg P/L (0.3 mL stock to 100 mL)

Table 3 Orthophosphate Calibrators:

Test Name	Working Standard	Dilution Factor	Concentration mg P/L
PO4CBL2	0.0558 mg P/L	1+15	0.00349
	0.0558 mg P/L	1+9	0.00558
	0.0558 mg P/L	1+6	0.00797
	0.0558 mg P/L	1+4	0.0116
	0.0558 mg P/L	1+2	0.0186
	0.0558 mg P/L	1+1	0.0279
	0.0558 mg P/L	1+0	0.0558
PO4HIGH	0.186 mg P/L	1+10	0.0169
	0.186 mg P/L	1+5	0.0310
	0.186 mg P/L	1+4	0.0372
	0.186 mg P/L	1+3	0.0465
	0.186 mg P/L	1+2	0.062
	0.186 mg P/L	1+1	0.093
	0.186 mg P/L	1+0	0.186
PPCBL	1.488 mg P/L	1+9	0.1488
	1.488 mg P/L	1+4	0.2976
	1.488 mg P/L	1+3	0.372
	1.488 mg P/L	1+2	0.496
	1.488 mg P/L	1+1	0.744
	1.488 mg P/L	1+0	1.488

10.2 The instrument software prepares a standard curve for each set of calibrators. A graph plotting measured absorbance against standard concentration is presented for review and approval. If acceptance criteria are not met the entire curve can be reanalyzed or individual standards can be reanalyzed. One standard value (original or reanalyzed) for each and every standard is incorporated in the curve. The coefficient of determination (Pearson's r value) for the calibration curve as well as the calculated concentration of each calibrator is reviewed. The calculated value of each calibrator must be within ten percent of the expected value. The coefficient of determination (Pearson's r value) for the calibration curve must be greater than 0.995.

11 PROCEDURE – DAILY OPERATIONS QUALITY CONTROL

- 11.1 Turn on computer. Computer will automatically initiate Konelab software. Once software is running, turn on instrument and allow connection between instrument and computer to complete.
- 11.2 Discard any water remaining in the water reservoir from the previous analytical run. Fill the water reservoir with fresh reagent water.
- 11.3 Remove samples from freezer to be analyzed. Allow samples to begin thawing. Begin daily bench sheet documentation.
- 11.4 Place cuvette waste box into cuvette waste sliding drawer.
- 11.5 Once water reservoir is full, use instrument software to click More, Instrument Actions, and Perform Water Wash.” – complete at least five perform water wash cycles.
- 11.6 After performing water washes, clean the dispensing needle by performing test washes. Click More, Instrument Actions, More, Adjustment Program. Once in the Adjustment Program click, 4-Dispensing Unit, 1-Dispenser, 8-Test Wash. Perform 8 to 10 Test Washing. When complete, press “Q” to quit until you are able to bring up the Main Page.
- 11.7 Perform Start Up operations by clicking Start Up at the bottom of the Main Page.
- 11.8 Gather working standards and reagents from refrigerator during startup. Assess standards and reagents. Remake anything that has exceeded the time over which it is considered stable.
- 11.9 Once startup is complete, check the instrument water blanks by clicking More, Instrument Actions, More, Check Water Blank. If any of the instrument blanks are outside their predefined and software controlled limits, the user will be notified on the main menu page. User takes corrective action to return instrument functions to controlled limits.
- 11.10 Load reagents in specified position in reagent carousel and place in refrigerated reagent compartment. Reagent positions can be found by clicking reagents at the top of the main page.
- 11.11 Load working standards in a sample segment, identify the standards in their positions from the drop down menus at the individual segment positions, and load into instrument. (Click Samples from the top of the Main Page, then click desired segment number.)
- 11.12 Select the methods to be calibrated by clicking Calibr./QC Selection on the bottom of the main page. Click PO4CBL2, PO4HIGH and PPCBL as the three methods to be calibrated, then click Calibrate at the bottom of the page. The three methods will now show as pending. Return to the main page. .
- 11.13 Start instrument and calibration by clicking Page Up on the keyboard. This may also be a green button on the keyboard – See test flow below for stepwise instrument functions for the analysis of standards and samples.

Test Flow – Method of Analysis, Stepwise

- 165 µL sample to cuvette with mixing
- Blank response measurement at 880 nm
- 14 µL Triple Reagent to cuvette with mixing

- 7 μL Ascorbic Acid Reagent to cuvette with mixing
 - Incubation, 600 seconds, 37°C
 - End point absorbance measurement, 880 nm
 - Software processes absorbance value, blank response value and uses calibration curve to calculate analyte concentration (mg/L P as PO_4)
 - User is notified if any measured values used to calculate final concentration are outside preset limits. If so, analyst has options to accept result, rerun the sample or rerun the sample diluted to a user or software specified factor.
 - User is notified of each blank response value. Blank response >0.001 absorbance units indicates a scratched cuvette or turbid sample. If the blank response value exceeds 0.001 absorbance units, the analyst specifies that the sample is reanalyzed. If the blank response value of the reanalyzed sample is <0.001 absorbance units, the reanalyzed result is accepted. If the same concentration and blank response value >0.001 absorbance units is again obtained, the results are accepted.
- 11.14 Organize samples, reagent blanks, check standards and all quality control samples while instrument performs calibrations.
- 11.15 As calibration curves are produced by the instrument, review them for acceptability. The instrument software prepares a standard curve for each set of calibrators. A graph plotting measured absorbance against standard concentration is presented for review and approval. If acceptance criteria are not met, either the entire curve shall be reanalyzed or individual standards shall be reanalyzed, depending on the violation. One standard value (original or reanalyzed) for each and every calibrator is incorporated in the curve.
- 11.16 Once calibration curves are accepted, samples are loaded into the sample segments and loaded into the instrument for analysis. After the Reagent Blank, the first sample analyzed should be an ICV (initial calibration verification) sample. There should be one ICV sample for each calibration curve, of a concentration close to the middle of each range. The following are recommended ICV samples for each curve: 0.0372 mg P/L for PO4CBL2, 0.1488 mg P/L for PO4HIGH and 1.116 mg P/L for PPCBL.
- 11.17 Samples are loaded into the segments and analyzed. CCV (Continuing Calibration Verification) samples (one for each of the three calibration ranges) follow every 18-23 samples. Standard Reference Material (SRM) samples, as well as Laboratory Reagent Blanks (LRB) are scattered throughout the analytical batch. Throughout the analytical batch, samples are chosen as laboratory duplicates and laboratory spikes to assess analyte precision and analyte recovery, respectively. The total number of duplicates and spikes performed will be equal or greater to ten percent of the total number of samples in the analytical batch.
- 11.18 As sample analysis is complete, results must be reviewed and accepted manually. If results fall outside acceptance limits, the sample should be reanalyzed. If sample result exceeds the highest standard of the highest calibration range, the samples can be automatically diluted by the instrument and reanalyzed. If the result is such that it will fall within a higher calibration range, it

- should be reanalyzed in the higher range. If the result is such that it will fall within a lower calibration range, it should be reanalyzed within the lower range.
- 11.19 Upon completion of all analysis, results are saved to a daily report file. Click Report on the bottom of the main page, More, Results To File, and select one row per result. The file is then named by the run date. The daily report file for analytical batch of July 1, 2017 would be named 070117. The file is converted to Microsoft Excel for data work up. Remaining samples are discarded.
- 11.20 All reagents are removed from the reagent chamber and returned to the refrigerator. Reagents that have exceeded their stability period are discarded.
- 11.21 Click on Stand By on the bottom of the main page and insert Aquakem Cleaning Solution into the instrument. This initiates shut down procedures. Daily files are cleared from the instrument software by clicking More, Management, Clear Daily Files. The software is exited and the instrument is turned off. The computer is turned off.
- 11.22 The waste is flushed down the drain with copious amounts of tap water. The waste cuvette box is moved to the fume hood and covered.

12 DATA ANALYSIS AND CALCULATIONS

- 12.1 Upon completion of all analysis, results are saved to a daily report file. The file is named by the run date. The daily report file for analytical batch of July 1, 2017 would be named 070117. The file is converted to Microsoft Excel for data work up. The instrument software has calculated final sample concentration from the designated standard curve, correcting each concentration for associated blank response and also for any user or instrument specified dilution. Dilution by the instrument is noted by software as analysis ensues and, also, documented in the Excel data report file. The analyst examines each row of data. Results are eliminated that are outside the limits of the calibration range, or have an unrepeated blank response measurement greater than 0.001 absorbance units.
- reagent

13 REFERENCES

- 13.1 USEPA. 1979. Method No. 365.1 *in* Methods for chemical analysis of water and wastes. United States Environmental Protection Agency, Office of Research and Development. Cincinnati, Ohio. Report No. EPA-600/4-79-020 March 1979. 460pp.
- 13.2 Frank, J. M., C.F. Zimmermann and C. W. Keefe (2006). Comparison of results from Konelab Aquakem 250 and existing nutrient analyzers. UMCES CBL Nutrient Analytical Services Laboratory, Dec. 2006.
- 13.3 Strickland, J.D.H. and T.R. Parsons. 1965. A Manual of Sea Water Analysis, 2nd ed. Fisheries Research Board of Canada, Ottawa.

UNIVERSITY OF MARYLAND CENTER FOR ENVIRONMENTAL SCIENCE
CHESAPEAKE BIOLOGICAL LABORATORY
NUTRIENT ANALYTICAL SERVICES LABORATORY
146 Williams St., Solomons MD 20688
<http://nasl.cbl.umces.edu/>

**Determination of Silicate from Fresh, Estuarine, and Coastal Waters
Using the Molybdosilicate Method**

(Reference Method: EPA Method 366.0)

**Revision 2017-1
Replaces revision 2015.
Effective April 26, 2017**

Revised by: _____ Date: _____

Reviewed by: _____ Date: _____

Laboratory Supervisor: _____ Date: _____

Changes affecting revision 2015

Section 1.4 Lower concentration range 0.01 to 10.5 mg Si/L

Section 1.7 Changed conforms to references

Section 3.4 Lower analytical range 0.01 to 10.5 mg Si/L

Section 3.5 Removed preparation batch

Section 3.12.3 Run CCV after every 18-23 samples

Section 3.22 Removed section 3.22 Instrument Detection Limit

Section 3.23 Changed apparatus to instrument

Section 3.25 Also referred to as MDL

Section 3.26 Also referred to as QL

Section 3.30 Changed 98% to 99% and added standard methods

Section 3.35 Also referred to as CRM

Section 3.37 Removed section 3.37 Run

Section 3.42 Also referred to as CRM

Section 5.1 Changed CBL Business Manager to Chesapeake Biological Laboratory (CBL)

Associate Director of Administration and Facilities Maintenance

Section 5.4 Added Detailed information is provided on Material Safety Data Sheets (MSDS), updated Table 1

Section 7.3 Changed reagent quantity from 1L to 500 mL

Section 7.4 Changed reagent quantity from 1L to 250 mL, Removed Divide into 4-6 bottles and freeze, changed stable for 6 months to 2 months

Section 7.5 Reagent is stable for 48 hours

Section 7.6 Changed 0.4394g to 0.4392g

Section 7.7 Changed reagent quantity from 1L to 500mL

Section 7.8 Changed standard quantity from 1L to 500mL, added at room temperature

Section 7.9 Changed 75mL to 55mL, Removed previous method

Section 9.2.2 Changed $\pm 10\%$ to 3s

Section 9.2.3 Changed ambient to natural

Section 9.2.4 Removed change of operator

Section 9.3.1 Changed Nanopure to reagent water, removed LRB above the lowest standard requires that the source of the problem must be identified and corrected before proceeding with analysis

Section 9.3.4 Included reagent blanks, removed set up an accuracy chart

Section 9.3.5 Added Initial and Continuing calibration verification, changed Regular Si and Si HIGH to SILCBL and SILCBLHI

Section 9.3.6 Removed section 9.3.6 Reagent Blank

Section 9.4.2 Changed % to percent, added Percent Recovery for each spike sample should fall within 80-120%

Section 9.7 Added Table 2

Section 10.1 Reworded and expanded

Section 10.2 Replaced write up with chart, changed 0.980 to 0.995

Section 11 Throughout changed all deionized water to reagent water, Added instrument software steps throughout the entire section

Section 11.8 Removed Molybdate reagent is made every other day

Section 11.15 Added One standard value for each and every calibrator is incorporated in the curve

Section 11.16 Added after the reagent blanks, changed usual to recommended
Section 12.4 Updated Example of sorted and edited spreadsheet of results
Section 13 Removed Method Performance section

Determination of Silicate from Fresh, Estuarine, and Coastal Waters Using the Molybdosilicate Method

1. SCOPE and APPLICATION

- 1.1. The reaction is based on the reduction of silicomolybdate in acidic solution to “molybdenum blue” by ascorbic acid. Oxalic acid is added to minimize interference from phosphates. The method is used to analyze all ranges of salinity.
- 1.2. A Method Detection Limit (MDL) of 0.01 mg Si/L was determined using the Student’s *t* value (3.14) times the standard deviation of seven replicates. If more than seven replicates are used to determine the MDL, refer to the Student’s *t* test table for the appropriate *n*-1 value.
- 1.3. The Quantitation Limit for Si was set at 0.03 mg Si/L.
- 1.4. The method is suitable for Si concentrations 0.01 to 10.5 mg Si/L.
- 1.5. This procedure should be used by analysts experienced in the theory and application of aqueous inorganic analysis. Three months experience with an analyst, experienced in the analysis of silicate in aqueous samples, is required.
- 1.6. This method can be used for all programs that require analysis of dissolved silicate.
- 1.7. This procedure references EPA Method 366.0. (1997).

2. SUMMARY

- 2.1. Filtered samples are mixed with oxalic acid, ammonium molybdate, and sulfuric acid. The resulting silicomolybdate is reduced to molybdenum blue by the addition of ascorbic acid. The oxalic acid is added to destroy molybdophosphoric acid formed from phosphorus in the sample.

3. DEFINITIONS

- 3.1. Acceptance Criteria - Specified limits placed on characteristics of an item, process, or service defined in a requirement document. (ASQC)
- 3.2. Accuracy - The degree of agreement between an observed value and an accepted reference value. Accuracy includes a combination of random error (precision) and systematic error (bias) components which are due to sampling and analytical operations; a data quality indicator. (QAMS)
- 3.3. Aliquot - A discrete, measured, representative portion of a sample taken for analysis. (EPA QAD Glossary)
- 3.4. Analytical Range – the analytical range is 0.01 to 10.5 mg Si/L. The overall analytical range is comprised of two distinct yet overlapping concentration ranges. A separate calibration is performed for each range. These ranges include 0.21 to 2.1 mg Si/L, and 1.05 to 10.5 mg Si/L. Two ranges are utilized so that samples can be analyzed on the most appropriate scale possible.

- 3.5. Batch – Environmental samples, which are prepared and /or analyzed together with the same process and personnel, using the same lot(s) of reagents. An **analytical batch** is composed of prepared environmental samples (extracts, digestates, concentrates) and/or those samples not requiring preparation, which are analyzed together as a group using the same calibration curve or factor. An analytical batch can include samples originating from various environmental matrices and can exceed 20 samples. (NELAC/EPA)
- 3.6. Blank - A sample that has not been exposed to the analyzed sample stream in order to monitor contamination during sampling, transport, storage or analysis. The blank is subjected to the usual analytical and measurement process to establish a zero baseline or background value and is sometimes used to adjust or correct routine analytical results. (ASQC)
- 3.7. Calibrate - To determine, by measurement or comparison with a standard, the correct value of each scale reading on a meter or other device, or the correct value for each setting of a control knob. The levels of the applied calibration standard should bracket the range of planned or expected sample measurements. (NELAC)
- 3.8. Calibration - The set of operations which establish, under specified conditions, the relationship between values indicated by a measuring device. The levels of the applied calibration standard should bracket the range of planned or expected sample measurements. (NELAC)
- 3.9. Calibration Blank – A volume of reagent water fortified with the same matrix as the calibration standards, without analyte added.
- 3.10. Calibration Curve – The graphical relationship between known values, such as concentrations, or a series of calibration standards and their analytical response. (NELAC)
- 3.11. Calibration Method - A defined technical procedure for performing a calibration. (NELAC)
- 3.12. Calibration Standard - A substance or reference material used to calibrate an instrument. (QAMS)
 - 3.12.1. Initial Calibration Standards (STD) - A series of standard solutions used to initially establish instrument calibration responses and develop calibration curves for individual target analytes.
 - 3.12.2. Initial Calibration Verification (ICV) - An individual standard, analyzed initially, prior to any sample analysis, which verifies acceptability of the calibration curve or previously established calibration curve.
 - 3.12.3. Continuing Calibration Verification (CCV) - An individual standard which is analyzed after every 18-23 field sample analysis.
- 3.13. Certified Reference Material (CRM) - A reference material one or more of whose property values are certified by a technically valid procedure, accompanied by or traceable to a certificate or other documentation which is issued by a certifying body. (ISO 17025).
- 3.14. Corrective Action - Action taken to eliminate the causes of an existing nonconformity, defect or other undesirable situation in order to prevent recurrence. (ISO 8402)
- 3.15. Deficiency - An unauthorized deviation from acceptable procedures or practices. (ASQC)
- 3.16. Demonstration of Capability -A procedure to establish the ability of the analyst to generate acceptable accuracy. (NELAC)

- 3.17. **Detection Limit** - The lowest concentration or amount of the target analyte that can be determined to be different from zero by a single measurement at a stated degree of confidence.
- 3.18. **Duplicate Analyses** - The analyses or measurements of the variable of interest performed identically on two sub samples (aliquots) of the same sample. The results from duplicate analyses are used to evaluate analytical or measurement precision but not the precision of sampling, preservation or storage external to the laboratory (EPA-QAD)
- 3.19. **External Standard (ES)** - A pure analyte (Sodium silicofluoride (Na_2SiF_6)) that is measured in an experiment separate from the experiment used to measure the analyte(s) in the sample. The signal observed for a known quantity of the pure external standard is used to calibrate the instrument response for the corresponding analyte(s). The instrument response is used to calculate the concentrations of the analyte(s) in the unknown sample.
- 3.20. **Field Duplicates (FD1 and FD2)** - Two separate samples collected at the same time and place under identical circumstances and treated exactly the same throughout field and laboratory procedures. Analyses of FD1 and FD2 give a measure of the precision associated with sample collection, preservation and storage, as well as with laboratory procedures.
- 3.21. **Holding Time** - The maximum time which samples may be held prior to analysis and still be considered valid. (40 CFR Part 136) The time elapsed from the time of sampling to the time of extraction or analysis, as appropriate.
- 3.22. **Laboratory Duplicates (LD1 and LD2)** - Two aliquots of the same sample taken in the laboratory and analyzed separately with identical procedures. Analyses of LD1 and LD2 indicate precision associated with laboratory procedures, but not with sample collection, preservation, or storage procedures.
- 3.23. **Laboratory Reagent Blank (LRB)** - A matrix blank that is treated exactly as a sample including exposure to all glassware, equipment, solvents, and reagents that are used with other samples. The LRB is used to determine if method analytes or other interferences are present in the laboratory environment, the reagents, or the instrument.
- 3.24. **Laboratory Control Sample (LCS)** - A sample matrix, free from the analytes of interest, spiked with verified known amounts of analytes from a source independent of the calibration standards or a material containing known and verified amounts of analytes. The LCS is generally used to establish intra-laboratory or analyst-specific precision and bias or to assess the performance of all or a portion of the measurement system. (NELAC)
- 3.25. **Limit of Detection (LOD)** - The lowest concentration level that can be determined by a single analysis and with a defined level of confidence to be statistically different from a blank. Also referred to as MDL. (ACS)
- 3.26. **Limit of Quantitation (LOQ)** - The minimum levels, concentrations, or quantities of a target variable (target analyte) that can be reported with a specified degree of confidence. The LOQ is set at 3 to 10 times the LOD, depending on the degree of confidence desired. Also referred to as Quantitation Limit.
- 3.27. **Linear Dynamic Range (LDR)** - The absolute quantity over which the instrument response to an analyte is linear. This specification is also referred to as the Linear Calibration Range (LCR).

- 3.28. Material Safety Data Sheet (MSDS) - Written information provided by vendors concerning a chemical's toxicity, health hazards, physical properties, fire, and reactivity data including storage, spill, and handling precautions.
- 3.29. May - Denotes permitted action, but not required action. (NELAC)
- 3.30. Method Detection Limit (MDL) - The minimum concentration of an analyte that can be identified, measured, and reported with 99% confidence that the analyte concentration is greater than zero (Standard Methods).
- 3.31. Must - Denotes a requirement that must be met. (Random House College Dictionary)
- 3.32. Photometer - measures the absorbance of the solution in the cell in a multicell cuvette. Light passes from the lamp through the condensing lenses to the interference filter. The plane surface of the first condensing lens is coated with a material which reflects heat and infrared light. The filters are mounted on a filter wheel. There are 15 positions for filters. Each filter corresponds to a wavelength of interest. The 660 nm filter is specified by the test definition for silicate. After passing through the filter the light is converted into a stream of light pulses by a chopper. Then the light is directed via a quartz fiber through a focusing lens and a slit to the beam divider. The beam divider divides the light into two parts. A specified portion is reflected to the reference detector, which monitors the light level fluctuations. The remaining major portion of the light beam goes through the liquid in the cell to the signal detector, which measures the amount of light absorbed.
- 3.33. Precision - The degree to which a set of observations or measurements of the same property, obtained under similar conditions, conform to themselves; a data quality indicator. Precision is usually expressed as standard deviation, variance or range, in either absolute or relative terms. (NELAC)
- 3.34. Preservation – Refrigeration, freezing and/or reagents added at the time of sample collection (or later) to maintain the chemical and or biological integrity of the sample.
- 3.35. Quality Control Sample (QCS) -A sample of analyte of known and certified concentrations. The QCS is obtained from a source external to the laboratory and different from the source of calibration standards. It is used to check laboratory performance with externally prepared test materials. Also referred to as CRM.
- 3.36. Run Cycle – Typically a day of operation – the entire analytical sequence from sampling the first standard to the last sample of the day.
- 3.37. Sample Segment – Bar-coded metal tray that holds up to fourteen four milliliter auto analyzer vials containing samples or standards. The user identifies each vial in the operating software.
- 3.38. Sample Segment Holder – An automated temperature controlled carousel that contains up to six sample segments. This carousel spins in clockwise or counterclockwise manner to move the sample segments into position for analysis. This carousel format allows for continuous processing.
- 3.39. Sensitivity - The capability of a test method or instrument to discriminate between measurement responses representing different levels (concentrations) of a variable of interest.
- 3.40. Shall - Denotes a requirement that is mandatory whenever the criterion for conformance with the specification requires that there be no deviation. (ANSI)
- 3.41. Should - Denotes a guideline or recommendation whenever noncompliance with the specification is permissible. (ANSI)

- 3.42. Standard Reference Material (SRM) - Material which has been certified for specific analytes by a variety of analytical techniques and/or by numerous laboratories using similar analytical techniques. These may consist of pure chemicals, buffers, or compositional standards. The materials are used as an indication of the accuracy of a specific analytical technique. Also referred to as CRM.
- 3.43. Test Definition – A photometric test consisting of a user defined testing sequence, reagent additions, calibration standards, incubations and absorption results.
- 3.44. Test Flow – Functions to define the parameter for reagent and sample dispensing, dilution, incubation and measurement







4. INTERFERENCES

- 4.1. Because both apparatus and reagents may contribute silica, avoid using glassware as much as possible and use reagents low in silica. Phosphate interference can be eliminated by the addition of oxalic acid.
- 4.2. Suspended matter in the sample will scatter light as it passes through the cuvette to the detector. High blank responses will result. The identified sample will be reanalyzed.
- 4.3. Blemishes in the cuvette, as result of the manufacturing process, will result in high blank responses. The identified sample will be reanalyzed.

5. SAFETY

- 5.1. Safety precautions must be taken when handling reagents, samples and equipment in the laboratory. Protective clothing including lab coats, safety glasses and enclosed shoes must always be worn. In certain situations it may also be necessary to use gloves and/or face shield. If solutions or chemicals come in contact with eyes, flush with water continuously for 15 minutes. If solutions or chemicals come in contact with skin, wash thoroughly with soap and water. Contact Solomons Rescue Squad (911) if emergency treatment is needed and also inform the Chesapeake Biological Laboratory (CBL) Associate Director of Administration and Facilities Maintenance of the incident. Contact the CBL Associate Director of Administration and Facilities Maintenance if additional treatment is required.
- 5.2. The toxicity or carcinogenicity of each reagent used in this procedure may not have been fully established. Each chemical should be regarded as a potential health hazard and exposure should be as low as reasonably achievable. Cautions are included for known extremely hazardous materials and procedures.
- 5.3. Do not wear jewelry when troubleshooting electrical components. Even low voltage points are dangerous and can injure if allowed to short circuit.
- 5.4. The following hazard classifications are listed for the chemicals regularly used in this procedure. Detailed information is provided on Material Safety Data Sheets (MSDS).

Table 1

Chemical	Health Hazard	Fire Hazard	Instability Hazard	Specific Hazard	
Sulfuric acid	4	0	2	ACID,COR	
Oxalic acid	3	0	0	ACID,COR	 
Ascorbic acid	1	0	0	ACID	
Ammonium molybdate	2	0	0	IRRITANT	 
Potassium phosphate	2	0	0	IRRITANT	
Sodium silicofluoride	2	0	0	IRRITANT	
Clorox	3	0	0		
<p>On a scale of 0 to 4 the substance is rated on four hazard categories: health, flammability, reactivity, and contact. (0 is non-hazardous and 4 is extremely hazardous)</p>					
<p>HAZARD RATING</p> <p>Health Hazard - Blue: 4 – deadly, 3 – extreme danger, 2 – hazardous, 1 – slightly hazardous, 0 – normal material</p> <p>Fire Hazard - Red: Flash Points: 4 – below 73° F, 3 – below 100° F, 2 – below 200° F, 1 – above 200° F, 0 – will not burn</p> <p>Instability Hazard - Yellow: 4 – may detonate, 3 – Shock and heat may detonate, 2 – violent chemical change, 1 – unstable is heated, 0 - stable</p> <p>Specific Hazard - White: Acid = ACID, Alkali = ALK, Corrosive = COR, Oxidizer = OXY</p>					

6. EQUIPMENT AND SUPPLIES

- 6.1. Aquakem 250 multi-wavelength automated discrete photometric analyzer. Aquakem 250 control software operates on a computer running Microsoft Windows NT, XP or 7 operating system.
- 6.2. Freezer, capable of maintaining $-20 \pm 5^{\circ} \text{C}$.
- 6.3. Refrigerator, capable of maintaining $4 \pm 2^{\circ} \text{C}$.
- 6.4. Lab ware – All reusable lab ware (glass, Teflon, plastic, etc.) should be sufficiently clean for the task objectives. This laboratory cleans all lab ware related to this method with a 10% HCl (v/v) acid rinse, followed by 4-6 reagent water rinses. This laboratory cleans all lab ware that has held solutions containing ammonium molybdate with 10% NaOH (w/v) rinse.

7. REAGENTS AND STANDARDS

- 7.1. Purity of Water – Unless otherwise indicated, references to water shall be understood to mean reagent water conforming to Specification D 1193, Type I. Freshly prepared water should be used for making the standards intended for calibration. The detection limits of this method will be limited by the purity of the water and reagents used to make the standards.
- 7.2. Purity of Reagents – Reagent grade chemicals shall be used in all tests. Unless otherwise indicated, it is intended that all reagents shall conform to specifications of the Committee on Analytical Reagents of the American Chemical Society, where such specifications are available. Other grades may be used, provided it is first ascertained that the reagent is of sufficiently high purity to permit its use without compromising the accuracy of the determination.

7.3. Oxalic Acid Solution -

Oxalic acid ($\text{H}_2\text{C}_2\text{O}_4 \cdot 2\text{H}_2\text{O}$)	50g
Reagent water	up to 500mL

In a 500mL plastic volumetric flask, dissolve 50g of oxalic acid in ~400mL reagent water and dilute to 500mL with reagent water. Write name of preparer, preparation date, reagent manufacturer, manufacturer's lot number in the Analytical Reagent log book. Store the flask at room temperature in the dark and make every 12 months.

7.4. Ascorbic Acid Solution -

Oxalic acid ($\text{H}_2\text{C}_2\text{O}_4 \cdot 2\text{H}_2\text{O}$)	1.25g
Ascorbic acid ($\text{C}_6\text{H}_8\text{O}_6$), U.S.P. quality	25g
Reagent water	up to 250mL

In a 250mL plastic volumetric flask, dissolve 1.25g of oxalic acid in ~100mL of reagent water. Add 25g of ascorbic acid and mix until dissolved. Dilute to 250mL with reagent water. Write name of preparer, preparation date, reagent manufacturers, manufacturers' lot numbers in the Analytical Reagent log book. Store at 4°C and make every 2 months.

7.5. Ammonium Molybdate Solution -

Ammonium molybdate [$(\text{NH}_4)_6\text{Mo}_7\text{O}_{24} \cdot 4\text{H}_2\text{O}$]	3.0g
Reagent water	up to 100mL

- 9.1. The laboratory is required to operate a formal quality control (QC) program. The minimum requirements of this program consist of an initial demonstration of laboratory capability and the continued analysis of laboratory instrument blanks field duplicates, and calibration standards analyzed as samples as a continuing check on performance. The laboratory is required to maintain performance records that define the quality of data generated.
- 9.2. Initial Demonstration of Capability
- 9.2.1. The initial demonstration of capability (iDOC) – is used to characterize instrument performance (MDLs) and laboratory performance (analysis of QC samples) prior to the analyses conducted by this procedure.
- 9.2.2. Quality Control Sample (QCS/SRM) – When using this procedure, a quality control sample is required to be analyzed at the beginning or middle and end of the run, to verify data quality and acceptable instrument performance. If the determined concentrations are not within $\pm 3s$ of the certified values, performance of the determinative step of the method is unacceptable. The source of the problem must be identified and corrected before proceeding with the initial determination of MDLs.
- 9.2.3. Method Detection Limits (MDLs) – MDLs should be established for Si using a low level natural water sample, typically three to five times higher than the estimated MDL. The same procedure should be followed for sediments or other weighed samples. To determine the MDL values, analyze seven replicate aliquots of water and process through the entire analytical procedure. Perform all calculations defined in the procedure (Section 12) and report the concentration values in the appropriate units. Calculate the MDL as follows:
- $$MDL = S t_{(n-1, 1-\alpha=0.99)}$$
- Where,
- S = Standard deviation of the replicate analyses.
n=number of replicates
 $t_{(n-1, 1-\alpha=0.99)}$ = Student's *t* value for the 99% confidence level with n-1 degrees of freedom ($t=3.14$ for 7 replicates.)
- 9.2.4. MDLs should be determined annually, whenever there is a significant change in instrumental response, or a significant change in instrument configuration.
- 9.3. Assessing Laboratory Performance
- 9.3.1. Laboratory Reagent Blank (LRB) – The laboratory must analyze at least one LRB with each batch of samples. The LRB consists of reagent water treated the same as the samples. Analyte found in LRB indicates possible reagent or laboratory environment contamination. LRB data are used to assess and correct contamination from the laboratory environment.
- 9.3.2. Quality Control Sample (QCS)/ Standard Reference Material (SRM)- When using this procedure, a quality control sample is required to be analyzed at the beginning and end of the run, to verify data quality and acceptable instrument performance. If the determined concentrations are not within $\pm 3s$ of the certified values, performance of the determinative step of the method is unacceptable. The source of

the problem must be identified and corrected before either proceeding with the initial determination of MDLs or continuing with the analyses. The results of these QCS/SRM samples shall be used to determine batch acceptance.

- 9.3.3. The QCS are obtained from a source external to the laboratory and different from the source of calibration standards.
- 9.3.4. Control Charts – The Accuracy Control Chart for QCS/SRM samples and reagent blanks is constructed from the average and standard deviation of the 20 most recent QCS/SRM measurements. The accuracy chart includes upper and lower warning levels ($WL = \pm 2s$) and upper and lower control levels ($CL = \pm 3s$). These values are derived from stated values of the QCS/SRM. The standard deviation (s) is specified relative to statistical confidence levels of 95% for WLS and 99% for CLs. Enter QCS/SRM results on the chart each time the sample is analyzed.
- 9.3.5. Calibration Verification , Initial and Continuing (ICV/CCV)– Immediately following calibration (ICV) and following every 18-23 samples (CCV), one calibration verification of 50 $\mu\text{M Si/L}$ (1.4 mg Si/L) for SILCBL, 250 $\mu\text{M Si/L}$ (7.0 mg Si/L) for SILCBLHI is analyzed to assess instrument performance. The CCVs are made from the same material as calibration standards (Na_2SiF_6), and are to be within $\pm 3s$. Failure to meet the criteria requires correcting the problem, including reanalysis of any affected samples. If not enough sample exists, the data must be qualified if reported.
- 9.4. Assessing Analyte Recovery
 - 9.4.1. Analyte recovery is assessed through percent recoveries of laboratory spikes.
 - 9.4.2. Percent Recovery = (Actual value/expected value) X 100. Percent Recovery for each spiked sample should fall within 80-120%.
- 9.5. Assessing Analyte Precision – Relative Percent Difference
 - 9.5.1. Analyte replication is assessed through duplicate analyses of samples – Relative Percent Difference.
 - 9.5.2. $RPD = (\text{Laboratory Duplicate Result 1} - \text{Laboratory Duplicate Result 2}) / [(\text{Laboratory Duplicate Result 1} + \text{Laboratory Duplicate Result 2}) / 2] \times 100$
- 9.6. Corrective Actions for Out-Of-Control Data
 - 9.6.1. Control limit – If one measurement exceeds Accuracy Control Chart CL, repeat the analysis immediately. If the repeat measurement is within the CL, continue analyses; if it exceeds the CL, discontinue analyses and correct the problem.
 - 9.6.2. Warning limit – If two out of three successive points exceed Accuracy Control Chart WL, analyze another sample. If the next point is within WL, continue analyses; if the next point exceeds the WL, evaluate potential bias and correct the problem.
 - 9.6.3. Trending – If seven successive Accuracy Control Chart measurements are on the same side of the central line, discontinue analyses and correct the problem.
 - 9.6.4. When external QCS samples are out of control, correct the problem. Reanalyze the samples analyzed between the last in-control measurement and the out-of-control one.
 - 9.6.5. When external CCV samples are out of control, correct the problem. Reanalyze the samples analyzed between the last in-control measurement and the out-of-control one.

9.7. General Operation - To assure optimal operation and analytical results, the Reagent Blank and CCV are tracked daily in the raw data file, copied to Reagent Blank and CCV Control Charts.

Table 2:

QC Indicator	Acceptance/ Action Limits	Action	Frequency (Batch)
Correlation Coefficient	≥ 0.995	If <0.995 , evaluate data points of the calibration curve. If any data point is outside established limits, reject as outlier.	1 per batch if acceptable.
Quality Control Sample (QCS)/ Certified Reference Material (CRM)	$\pm 10\%$	If QCS value is outside $\pm 10\%$ of the target value reject the run, correct the problem and rerun samples.	Beginning of run and at end of run.
Initial Calibration Verification (ICV)	$\pm 10\%$	Recalibrate if outside acceptance limits.	Beginning of run following standard curve.
Continuing Calibration Verification (CCV)	$\pm 10\%$	If outside 10%, correct the problem. Rerun all samples following the last in-control CCV.	After every 18-23 samples.
Method Blank/Laboratory Reagent Blank (LRB)	\leq Method Quantitation Limit	If the LRB exceeds the quantitation limit, results are suspect. Rerun the LRB. If the concentration still exceeds the quantitation limit, reject or qualify the data, or raise the quantitation limit.	Following the ICV and after every 18-23 samples following the CCV.
Laboratory Fortified Sample Matrix Spike	$\pm 20\%$	If the recovery of any analyte falls outside the designated acceptance limits and the QCS is in control, the recovery problem is judged matrix induced. Repeat the LFM and if the sample results are again outside the acceptable recovery range, the sample should be reported with a "matrix induced bias" qualifier.	1/10 (spike OR duplicate)

Laboratory Duplicate	± 20%	If the RPD fails to meet the acceptance limits, the samples should be reanalyzed. If the RPD again fails to meet the acceptance limits, the sample must be reported with a qualifier identifying the sample analysis result as not having acceptable RPD for duplicate analysis.	1/10 (spike OR duplicate)
----------------------	-------	--	---------------------------

10. CALIBRATION AND STANDARDIZATION

10.1. Calibration - Daily calibration must be performed before sample analysis may begin. Five point calibrations are used with each of the two sub- calibrations that cover the analytical range. Two working silicate standards are used to produce the calibrators for each set of two calibration curves. The instrument performs serial dilutions of working standards to produce the five calibrators defined for each curve. The following outlines the preparation of the working standards and the following table describes the subsequent serial dilutions the instrument performs to make each standard for each of the two calibration curves.

10.2. Silicate Working Standards- Si (SILCBL)

Working Standard 2.1 mg Si/L (0.75 mL stock standard to 100 mL)
 Working CCV 1.4 mg Si/L (0.5 mL stock standard to 100 mL)

High Si (SILCBLHI)

Working Standard 10.5 mg Si/L (3.75 mL stock standard to 100 mL)
 Working CCV 7.0 mg Si/L (2.5 mL stock standard to 100 mL)

Write name of preparer, preparation date, Stock Standard preparation date in the Analytical Standard log book. Make fresh every month.

Silicate Calibrators:

Test Name	Working Standard	Dilution Factor	Concentration mg Si/L
SILCBL	2.1 mg Si/L	1+9	0.21
	2.1 mg Si/L	1+4	0.42
	2.1 mg Si/L	1+2	0.70
	2.1 mg Si/L	1+1	1.05
	2.1 mg Si/L	1+0	2.10
SILCBLHI	10.5 mg Si/L	1+9	1.05
	10.5 mg Si/L	1+4	2.10
	10.5 mg Si/L	1+2	3.50
	10.5 mg Si/L	1+1	5.25
	10.5 mg Si/L	1+0	10.5

The instrument software prepares a standard curve for each set of calibrators. A graph plotting measured absorbance against standard concentration is presented for review and approval. If acceptance criteria are not met the entire curve can be reanalyzed or individual standards can be reanalyzed. One standard value (original or reanalyzed) for each and every standard is incorporated in the curve. The coefficient of determination (Pearson's r value) for the calibration curve as well as the calculated concentration of each calibrator is reviewed. The calculated value of each calibrator must be within ten percent of the expected value. The coefficient of determination (Pearson's r value) for the calibration curve must be greater than 0.995.

11. PROCEDURE – DAILY OPERATIONS AND QUALITY CONTROL

- 11.1. Turn on computer. Computer will automatically initiate Konelab software. Once software is running, turn on instrument and allow connection between instrument and computer to complete.
- 11.2. Discard any water remaining in the water reservoir from the previous analytical run. Fill the water reservoir with fresh reagent water.
- 11.3. Remove from refrigerator samples and SRM that will be analyzed that day. Begin daily bench sheet documentation.
- 11.4. Place cuvette waste box into cuvette waste sliding drawer.
- 11.5. Once water reservoir is full, use instrument software to click More, Instrument Actions, and Perform Water Wash. – complete at least five water wash cycles
- 11.6. After performing water washes, clean the dispensing needle by performing test washes. Click More, Instrument Actions, More, Adjustment Program. Once in the Adjustment Program click, 4-Dispensing Unit, 1-Dispenser, 8-Test Wash. Perform 8 to 10 Test Washing. When complete, press “Q” to quit until you are able to bring up the Main Page.
- 11.7. Perform Start Up operations by clicking Start Up at the bottom of the Main Page.
- 11.8. Gather working standards and reagents from refrigerator during startup. Assess standards and reagents. Remake anything that has exceeded the time over which it is considered stable.
- 11.9. Once startup is complete, check the instrument water blanks by clicking More, Instrument Actions, More, Check Water Blank. If any of the instrument blanks are outside their predefined and software controlled limits, the user will be notified on the main menu page. User takes corrective action to return instrument functions to controlled limits.
- 11.10. Load reagents into reagent carousel and place into refrigerated reagent compartment. Reagent position can be found by clicking reagents at the top of the main page.
- 11.11. Load working standards into a sample segment, identify the standards in their positions from the drop down menus at the individual segment positions, and load into instrument. (Click Samples from the top of the Main Page, then click desired segment number).
- 11.12. Select the methods to be calibrated by clicking Calibr. /QC Selection on the bottom of the main page. Click SILCBL and SILCBLHI as the two methods to be

calibrated, and then click Calibrate at the bottom of the page. The two methods will now show as pending. Return to the main page. .

- 11.13. Begin calibration by clicking Page Up on the keyboard. This may also be a green button on the keyboard – See test flow below for stepwise instrument functions for the analysis of standards and samples.

Test Flow – Method of Analysis, Stepwise

- 100 μL SAMPLE to cuvette
 - End point absorbance measurement at 660 nm for sample blank determination
 - 31 μL sulfuric acid solution (H2S SILCBL) to cuvette with mixing
 - 39 μL ammonium molybdate solution (MOL SILCBL) reagent to cuvette with mixing
 - Incubation, 30 seconds
 - 62 μL oxalic acid solution (OXA SILCBL) to cuvette with mixing
 - Incubation, 30 seconds
 - 16 μL ascorbic acid solution (ASC SILCBL) to cuvette with mixing
 - Incubation, 600 seconds
 - End point absorbance measurement, 660 nm
 - Software processes absorbance value and uses calibration curve to calculate analyte concentration (mg/L of Si)
 - User is notified if any measured values used to calculate final concentration are outside preset limits. If so, user has options to accept result, rerun the sample or rerun the sample diluted to a user or software specified factor.
- 11.14. Organize samples, reagent blanks, check standards and all quality control samples while instrument performs calibrations.
- 11.15. As calibration curves are produced by the instrument, review them for acceptability. The instrument software prepares a standard curve for each set of calibrators. A graph plotting measured absorbance against standard concentration is presented for review and approval. If acceptance criteria are not met, either the entire curve shall be reanalyzed or individual standards shall be reanalyzed, depending on the violation. One standard value (original or reanalyzed) for each and every calibrator is incorporated in the curve.
- 11.16. Once calibration curves are accepted, samples are loaded into the sample segments and loaded into the instrument for analysis. After the reagent blanks the first samples analyzed should be ICV (initial calibration verification) samples. There should be one sample for each calibration curve, of a concentration close to the middle of each range. The following are recommended ICV samples for each curve: 1.4 mg Si/L for SILCBL, and 7.0 mg Si/L for SILCBLHI.
- 11.17. Samples are loaded into the segments and analyzed. CCV (Continuing Calibration Verification) samples (one for each of the two calibration ranges) follow every 18-23 samples. Standard Reference Material (SRM) samples as well as Laboratory Reagent Blanks (LRB) are scattered throughout the analytical batch. Throughout the analytical batch, samples are chosen as laboratory duplicates and laboratory spikes to assess analyte precision and analyte recovery, respectively. The total number of duplicates and spikes performed will be equal to or greater than ten percent of the total number of samples in the analytical batch.

- 11.18. As sample analysis is complete, results must be reviewed and accepted manually. If results fall outside acceptance limits, the sample should be reanalyzed. If sample result exceeds the highest standard of the highest calibration range, the samples can be automatically diluted by the instrument and reanalyzed. If the result is such that it will fall within a higher calibration range, it should be reanalyzed in the higher range. If the result is such that it will fall within a lower calibration range, it should be reanalyzed within the lower range.
- 11.19. Upon completion of all analysis, results should be saved to a daily report file. Click Report on the bottom of the main page, More, Results To File, and select one row per result. The file is then named by the run date. The daily report file for analytical batch of January 2, 2017 would be named 010217. The file is converted to Microsoft Excel for data work up and copied to a removable flash drive. Remaining samples are discarded.
- 11.20. All reagents are removed from the reagent chamber and returned to the refrigerator. Reagents that have exceeded their stability period are discarded.
- 11.21. Initiate the shutdown procedure, click on Stand By at the bottom of the main page and insert AquaKem Cleaning Solution into the instrument. Daily files are cleared from the instrument software by clicking More, Management, Clear Daily Files. Once prompted remove the AquaKem Cleaning Solution from the instrument. The software is exited and the instrument is turned off. The computer is turned off.
- 11.22. The waste is flushed down the drain with copious amounts of tap water. The waste cuvette box is moved to the fume hood and covered. The instrument is wiped clean of drips or splashes.

12. DATA ANALYSIS AND CALCULATIONS

- 12.1. Upon completion of all analysis, results are saved to a daily report file. The file is named by the run date. The daily report file for analytical batch of January 1, 2017 would be named 010117. Raw results for each run are copied into a Microsoft Excel spreadsheet. Data are sorted by sample name and time of analysis so that all samples will be displayed by number and results for each sample will be displayed consecutively.
- 12.2. Dilution by the instrument is noted by software as analysis ensues and, also, documented in the data report spreadsheet. The analyst examines each row of data. Results are eliminated that are outside the limits of the calibration range, or have an unrepeated high blank response greater than 0.001 absorbance units.
- 12.3. The analyst examines salinity data for each sample. For all samples with salinity above 0.1 ppt, CBL Nutrient Analytical Services Laboratory's empirically derived salinity correction is applied to the original undiluted reported concentration.
- Salinity Corrected mg Si/L= (((100-((0.0103* (salinity*salinity)) + (-0.9113*salinity) +98.434))/100) +1)* Uncorrected mg Si/L

12.4. Example of sorted and edited spreadsheet of results:

	A	B	C	D	E	F
1	DNR MAINSTEM JANUARY 2017					
2	Aquakem v. 7.2.AQ2 KLAB1					
3	REC' 1/20/17					
4	ANALYZED 1/24/17					
5	CLH					
6						
7	Sample ID	mg Si/L	ERROR CODE			
8	11	0.03				
9	12	0.03				
10	13	0.03				
11	24	0.04				
12	25	0.14				
13	37	1.17				
14						
15	QA/QC					
16						
17	LAB DUPS					
18	SAMPLE	DUP 1	DUP 2	MEAN		
19	50	1.97	2.06	2.02		
20						
21	LAB SPIKES					
22	SAMPLE	ACTUAL	EXPECTED	ORIGINAL	SPIKE CONC	
23	25	1.02	1.08	0.14	10.5	
24						
25	SAMPLE	Preparation	Analysis	Parameter	Expected	Actual
26	NAME	Date	Date			
27	1.4 CCV	12/16/2016	1/24/2017	Si	1.40	1.41
28	7.0 CCV	12/16/2016	1/24/2017	Si	7.00	6.99
29	CRM	8/4/2016	1/24/2017	Si	1.56	1.56
30	DHOH	1/24/2017	1/24/2017	Si	0	0.02

- 12.4.1. Cell 1A – Client Name
- 12.4.2. Cell 2A – Instrument and software version
- 12.4.3. Cell 3A – Date Samples Received
- 12.4.4. Cell 4A – Date Samples analyzed
- 12.4.5. Cell 5A – Analyst Initials
- 12.4.6. Cell 7A – Column heading for sample
- 12.4.7. Cell 7B - Column heading for Si concentration in units of mg Si/L
- 12.4.8. Cell 7C- Column heading for error code
- 12.4.9. Cells 8A to 13B – Sample Results table
- 12.4.10. Cells 17A-19D- QA/QC table for instrument duplicates. The mean value is reported in the sample table.
- 12.4.11. Cells 21A to 23E- Laboratory spikes table
- 12.4.12. Cells 27C-30C- Analysis date
- 12.4.13. Cells 27D-30D- Parameter name

- 12.4.14. Cells 27E-30E-Expected value
- 12.4.15. Cell 27A to 28B- CCV name and date
- 12.4.16. Cell 27F-28F – CCV concentration, mg Si/L
- 12.4.17. Cell 29A-29B – SRM/CRM name and date
- 12.4.18. Cell 29F – SRM/CRM concentration, mg Si/L
- 12.4.19. Cells30A-30B– Reagent water blank name (DHOH) and date
- 12.4.20. Cells 30F – Reagent water blank concentration, mg Si/L
- 12.5. Report analyte concentrations in mg Si/L
- 12.6. Report analyte concentrations to two decimal places.

13. POLLUTION PREVENTION

- 13.1. Pollution prevention encompasses any technique that reduces or eliminates the quantity of toxicity of waste at the point of generation. Numerous opportunities for pollution prevention exist in laboratory operation. The USEPA has established a preferred hierarchy of environmental management techniques that places pollution as the management option of first choice. Whenever feasible, laboratory personnel should use pollution prevention techniques to address their waste generation. When wastes cannot be feasibly reduced at the source, the agency recommends recycling as the next best option.
- 13.2. For information about pollution prevention that may be applicable to laboratories and research institutions, consult “Less is Better: Laboratory Chemical Management for Waste Reduction”, available from the American Chemical Society, Department of Government Relations and Science Policy, 1155 16th Street N. W., Washington, D.C. 20036.

14. WASTE MANAGEMENT

- 14.1. The reagents used in this procedure are minimal and are not hazardous with the exception of the sulfuric acid. Due to the small quantity used, the sulfuric acid and other reagents can be flushed down the drain with running water.
- 14.2. For further information on waste management consult The Waste Management Manual for Laboratory Personnel, available from the American Chemical Society.

15. REFERENCES

- 15.1. U.S. Environmental Protection Agency, 1997. Methods for the Determination of Chemical Substances in Marine and Estuarine Environmental Samples. Method 366.0. U.S. Environmental Protection Agency. Washington, D.C.
- 15.2. Grasshoff, K., M. Ehrhardt and K. Kremling (eds). 1983. Methods of Seawater Analysis. Verlag Chemie. Weinheim, Germany.
- 15.3. Frank, J. M., C.F. Zimmermann and C. W. Keefe (2006). Comparison of results from Konelab Aquakem 250 and existing nutrient analyzers. UMCES CBL Nutrient Analytical Services Laboratory, Dec. 2006.

UNIVERSITY OF MARYLAND CENTER FOR ENVIRONMENTAL SCIENCE
CHESAPEAKE BIOLOGICAL LABORATORY
NUTRIENT ANALYTICAL SERVICES LABORATORY
146 Williams St., Solomons MD 20688
<http://nasl.cbl.umces.edu/>

**Standard Operating Procedure for
Determination of Total Dissolved Nitrogen (TDN) and Total Nitrogen (TN) in
Fresh/Estuarine/Coastal Waters Using Alkaline Persulfate Digestion of Nitrogen to
Nitrate and Measured Using Enzyme Catalyzed Reduction
(References EPA 353.2, Standard Methods #4500-N C, 4500-NO3 F)**

**Revision 2017-1
Replaces Revision 2015
Effective April 26, 2017**

Revised by: _____ Date: _____

Reviewed by: _____ Date: _____

Laboratory Supervisor: _____ Date: _____

Changes affecting Revision 2015

Section 1.3: Inserted If more than seven replicates are used to determine the MDL, refer to the Student's *t* test table for the appropriate n-1 value.

Section 1.5: Changed cadmium to enzyme

Section 1.7: Used references instead of conforms

Section 2.1: Added (whole water for TN)

Entire Document: Changed Table 1 to Appendix 1

Section 3.5: Deleted preparation batch definition

Section 3.23: Deleted Instrument Detection Limit

Entire Document: Changed deionized water to reagent water

Section 3.24: Changed blank matrix to matrix blank

Section 3.26: Added This is also referred to as MDL.

Section 3.27: Added This is also referred to as the Quantitation Limit

Section 3.30: Deleted Manifold definition

Section 3.36: Added Also referred to as CRM

Section 3.43: Added Also referred to as CRM

Section 5.1 Changed the word should to must, Changed CBL Business Manager to the CBL Associate Director of Administration and Facilities Maintenance

Section 5.4: Updated Chemical Safety Table (Table 1)

Section 6.1: Added Windows operating system

Section 7.4: Changed EDTA concentration to 0.25M

Section 7.7: Changed Sulfanilamide concentration to be made in 500 ml instead of 1L

Section 7.8: Changed N-1-Nap concentration to be made in 500mL instead of 1L

Section 7.9: Changed KNO₃ standard to be made in 500mL instead of 1L

Section 7.11: Changed NaNO₂ standard to be made in 500 ml instead of 1L

Section 7.12: Added secondary nitrite standard information

Section 7.12: Changed the Aquakem Cleaning Solution to be made with 55mL instead of 75mL

Section 8.4: Added \leq sign for freezer temp

Section 9.2.1: Changed the initial demonstration of capability acronym to IDOC

Section 9.2.2: Changed QCS checks from 10% to 3s

Section 9.2.3: Deleted from MDL description the change of operator or a new matrix is encountered, changed ambient water to natural water

Section 9.3.4: Added and digested reagent blanks, deleted Set up an accuracy chart by using percent recovery since the concentration of the QCS/SRM varies

Section 9.3.5: Added ICV information to the CCV, Added See Appendix 1 for additional CCVs,

Changed TV to the expected value

Section 9.4: Changed % to read Percent

Section 9.7: Added Table 2

Section 10.3: Added the coefficient of determination (Pearson's *r* value) for the calibration curve as well as the calculated concentration of each calibrator is reviewed. The calculated value of each calibrator must be within ten percent of the expected value. The coefficient of determination (Pearson's *r* value) for the calibration curve must be greater than 0.998

Section 11: Added step by step descriptions for using Aquakem software

Section 12.3.5: Changed % to percent

Section 12.3.6: Added labeled RB

Section 12.13: Changed digestion time to 55 minutes

Section 14: Deleted Method Performance section

Determination of Total Dissolved Nitrogen (TDN) and Total Nitrogen (TN) in Fresh/Estuarine/Coastal Waters Using Alkaline Persulfate Digestion of Nitrogen to Nitrate and Measured Using Enzyme Catalyzed Reduction

1. SCOPE and APPLICATION

1.1 Potassium Persulfate is used to oxidize organic and inorganic nitrogen to NO_3 under heated alkaline conditions.

1.2 Enzyme catalyzed reduction is used to quantitatively reduce dissolved nitrate to nitrite which is then measured by colorimetric quantitative analysis of a highly colored azo dye. The method is used to analyze all ranges of salinity.

1.3 A Method Detection Limit (MDL) of 0.05 mg TDN as $\text{NO}_3\text{-N/L}$ was determined using the Student's t value (3.14, $n=7$) times the standard deviation of a minimum of 7 replicates. If more than seven replicates are used to determine the MDL, refer to the Student's t test table for the appropriate $n-1$ value.

1.4 The Quantitation Limit for TDN as NO_3 was set at 0.15 mg TDN as $\text{NO}_3\text{-N/L}$.

1.5 This procedure should be used by analysts experienced in the theory and application of aqueous organic and inorganic analysis. A three month training period with an analyst experienced in the analysis of TDN in aqueous samples by enzyme reduction is required.

1.6 This method can be used for all programs that require analysis of TDN.

1.7 A portion of this procedure references to Standard Methods #4500-N C, 4500-NO3 F and EPA Method 353.2 (1979). Method for Nitrate Reductase Nitrate-Nitrogen Analysis (ATP Case No. N07-0003) has been reviewed by the US EPA and is awaiting final approval. It is now part of the EPA Methods Update Rule 2015 and has been published to the EPA Federal Register Vol. 80 No. 33. It is recommended as an addition of approved methods at 40 CFR Part 136 and currently accepting comments.

2. SUMMARY

2.1 An exact amount of filtered samples (whole water for TN) are placed in test tubes where an exact amount of Potassium Persulfate Digestion Reagent is added. Under initially alkaline conditions and heat, nitrate is the sole nitrogen product.

2.2 The now digested samples are buffered, then mixed with Nitrate Reductase (AtNaR2, commercially available, is a recombinantly produced form of eukaryotic Nitrate Reductase using a modified gene from the plant *Arabidopsis thaliana*. The enzyme AtNaR2 is produced in *Pichia pastoris* and purified from extracts of the yeast.) and NADH (β -Nicotinamide adenine dinucleotide reduced form disodium salt). The

nitrite, both that which was reduced from nitrate and nitrite that was originally present, is then determined by diazotizing with sulfanilamide and coupling with N-1-naphthylethylenediamine dihydrochloride to form a colored azo dye.

3. DEFINITIONS

- 3.1 Acceptance Criteria – Specified limits placed on characteristics of an item, process, or service defined in a requirement document. (ASQC)
- 3.2 Accuracy – The degree of agreement between an observed value and an accepted reference value. Accuracy includes a combination of random error (precision) and systematic error (bias) components which are due to sampling and analytical operations; a data quality indicator. (QAMS)
- 3.3 Aliquot – A discrete, measured, representative portion of a sample taken for analysis. (EPA QAD Glossary)
- 3.4 Analytical Range – There are multiple analytical ranges/standard curves used for determination of TDN. See Appendix 1 for all analytical ranges used.
- 3.5 Batch – Environmental samples, which are prepared and /or analyzed together with the same process and personnel, using the same lot(s) of reagents. An **analytical batch** is composed of prepared environmental samples (extracts, digestates, or concentrates) and/or those samples not requiring preparation, which are analyzed together as a group using the same calibration curve or factor. An analytical batch can include samples originating from various environmental matrices and can exceed 20 samples. (NELAC/EPA)
- 3.6 Blank- A sample that has not been exposed to the analyzed sample stream in order to monitor contamination during sampling, transport, storage or analysis. The blank is subjected to the usual analytical and measurement process to establish a zero baseline or background value and is sometimes used to adjust or correct routine analytical results. (ASQC)
- 3.7 Calibrate- To determine, by measurement or comparison with a standard, the correct value of each scale reading on a meter or other device, or the correct value for each setting of a control knob. The levels of the applied calibration standard should bracket the range of planned or expected sample measurements. (NELAC)
- 3.8 Calibration – The set of operations which establish, under specified conditions, the relationship between values indicated by a measuring device. The levels of the applied calibration standard should bracket the range of planned or expected sample measurements. (NELAC)
- 3.9 Calibration Blank – A volume of reagent water fortified with the same matrix as the calibration standards, without the analyte added.

- 3.10 Calibration Curve – The graphical relationship between known values, such as concentrations, or a series of calibration standards and their analytical response. (NELAC)
- 3.11 Calibration Method – A defined technical procedure for performing a calibration. (NELAC)
- 3.12 Calibration Standard – A substance or reference material used to calibrate an instrument. (QAMS)
 - 3.12.1 Initial Calibration Standard (STD) – A series of standard solutions used to initially establish instrument calibration responses and develop calibration curves for individual target analytes.
 - 3.12.2 Initial Calibration Verification (ICV) – An individual standard, analyzed initially, prior to any sample analysis, which verifies acceptability of the calibration curve or previously established calibration curve.
 - 3.12.3 Continuing Calibration Verification (CCV) – An individual standard which is analyzed after every 18-23 field sample analysis.
- 3.13 Certified Reference Material – A reference material one or more of whose property values are certified by a technically valid procedure, accompanied by or traceable to a certificate or other documentation which is issued by a certifying body. (ISO 17025)
- 3.14 Corrective Action – Action taken to eliminate the causes of an existing nonconformity, defect or other undesirable situation in order to prevent recurrence. (ISO 8402)
- 3.15 Deficiency – An unauthorized deviation from acceptable procedures or practices. (ASQC)
- 3.16 Demonstration of Capability – A procedure to establish the ability of the analyst to generate acceptable accuracy. (NELAC)
- 3.17 Detection Limit – The lowest concentration or amount of the target analyte that can be determined to be different from zero by a single measurement at a stated degree of confidence.
- 3.18 Duplicate Analysis – The analyses of measurements of the variable of interest performed identically on two sub samples (aliquots) of the same sample. The results from duplicate analyses are used to evaluate analytical or measurement precision but not the precision of sampling, preservation or storage internal to the laboratory. (EPA-QAD)
- 3.19 External Standard (ES) – A pure analyte (potassium nitrate (KN O₃)) that is measured in an experiment separate from the experiment used to measure the analyte(s) in the sample. The signal observed for a known quantity of the pure external standard is used to calibrate the instrument response for the corresponding analyte(s). The instrument response is used to calculate the concentrations of the analyte(s) in the unknown sample.
- 3.20 Field Duplicates (FD1 and FD2) – Two separate samples collected at the same time and place under identical circumstances and treated

exactly the same throughout field and laboratory procedures. Analyses of FD1 and FD2 provide a measure of the precision associated with sample collection, preservation and storage, as well as with laboratory procedures.

- 3.21 Field Reagent Blank (FRB) – A aliquot of reagent water or other blank matrix that is placed in a sample container in the laboratory and treated as a sample in all respects, including shipment to the sampling site, exposure to the sampling site conditions, storage, preservation, and all analytical procedures. The purpose of the FRB is to determine if method analytes or other interferences are present in the field environment.
- 3.22 Holding time – The maximum time that samples may be held prior to analysis and still be considered valid. (40 CFR Part 136) The time elapsed from the time of sampling to the time of extraction or analysis, as appropriate.
- 3.23 Laboratory Duplicates (LD1 and LD2) – Two aliquots of the same sample taken in the laboratory and analyzed separately with identical procedures. Analyses of LD1 and LD2 indicate precision associated with laboratory procedures, but not with sample collection, preservation, or storage procedures.
- 3.24 Laboratory Reagent Blank (LRB) – A matrix blank (i.e., reagent water) that is treated exactly as a sample including exposure to all glassware, equipment, solvents, and reagents that are used with other samples. The LRB is used to determine if method analytes or other interferences are present in the laboratory environment, the reagents, or the instrument.
- 3.25 Laboratory Control Sample (LCS) – A sample matrix, free from the analytes of interest, spiked with verified known amounts of analytes from a source independent of the calibration standard or a material containing known and verified amounts of analytes. The LCS is generally used to establish intra-laboratory or analyst-specific precision and bias or to assess the performance of all or a portion of the measurement system. (NELAC)
- 3.26 Limit of Detection (LOD) – The lowest concentration level that can be determined by a single analysis and with a defined level of confidence to be statistically different from a blank. This is also referred to as MDL. (ACS)
- 3.27 Limit of Quantitation (LOQ) – The minimum levels, concentrations, or quantities of a target variable (target analyte) that can be reported with a specified degree of confidence. The LOQ is set at 3 to 10 times the LOD, depending on the degree of confidence desired. This is also referred to as the Quantitation Limit.
- 3.28 Linear Dynamic Range (LDR) – The absolute quantity over which the instrument response to an analyte is linear. This specification is also referred to as the Linear Calibration Range (LCR).

- 3.29 Material Safety Data Sheets (MSDS) – Written information provided by vendors concerning a chemical’s toxicity, health hazards, physical properties, fire, and reactivity data including storage, spill, and handling precautions.
- 3.30 May – Denotes permitted action, but not required action. (NELAC)
- 3.31 Method Detection Limit (MDL) – The minimum concentration of an analyte that can be identified, measured, and reported with 99% confidence that the analyte concentration is greater than zero.
- 3.32 Must – Denotes a requirement that must be met. (Random House College Dictionary)
- 3.33 Photometer – measures the absorbance of the solution in the cell in a multicell cuvette. Light passes from the lamp through the condensing lenses to the interference filter. The plane surface of the first condensing lens is coated with a material which reflects heat and infrared light. The filters are mounted on a filter wheel. There are 15 positions for filters. Each filter corresponds to a wavelength of interest. The 540 nm filter is specified by the test definition for nitrate plus nitrite. After passing through the filter the light is converted into a stream of light pulses by a chopper. Then the light is directed via a quartz fiber through a focusing lens and a slit to the beam divider. The beam divider divides the light into two parts. A specified portion is reflected to the reference detector, which monitors the light level fluctuations. The remaining major portion of the light beam goes through the liquid in the cell to the signal detector, which measures the amount of light absorbed.
- 3.34 Precision – The degree to which a set of observations or measurements of the same property, obtained under similar conditions, conform to themselves; a data quality indicator. Precision is usually expressed as standard deviation, variance or range, in either absolute or relative terms. (NELAC)
- 3.35 Preservation – Refrigeration, freezing, and/or reagents added at the time of sample collection (or later) to maintain the chemical and or biological integrity of the sample.
- 3.36 Quality Control Sample (QCS) – A sample of analyte of known and certified concentration. The QCS is obtained from a source external to the laboratory and different from the source of calibration standards. It is used to check laboratory performance with externally prepared test materials. Also referred to as CRM.
- 3.37 Run Cycle – Typically a day of operation – the entire analytical sequence from sampling the first standard to the last sample of the day.
- 3.38 Sample Segment – Bar-coded metal tray that holds up to fourteen four milliliter auto analyzer vials containing samples or standards. The user identifies each vial in the operating software.
- 3.39 Sample Segment Holder – An automated temperature controlled carousel that contains up to six sample segments. This carousel spins

in clockwise or counterclockwise manner to move the sample segments into position for analysis. This carousel format allows for continuous processing.

- 3.40 Sensitivity – The capability of a test method or instrument to discriminate between measurement responses representing different levels (concentrations) of a variable of interest.
- 3.41 Shall – Denotes a requirement that is mandatory whenever the criterion for conformance with the specification requires that there be no deviation. (ANSI)
- 3.42 Should – Denotes a guideline or recommendation whenever noncompliance with the specification is permissible. (ANSI)
- 3.43 Standard Reference Material (SRM) – Material which has been certified for specific analytes by a variety of analytical techniques and/or by numerous laboratories using similar analytical techniques. These may consist of pure chemicals, buffers, or compositional standards. The materials are used as an indication of the accuracy of a specific analytical technique. Also referred to as CRM.
- 3.44 Test Definition – A photometric test consisting of a user defined testing sequence, reagent additions, calibration standards, incubations and absorption results.
- 3.45 Test Flow – Functions to define the parameter for reagent and sample dispensing, dilution, incubation and measurement.

4 INTERFERENCES

- 4.1 Metals, highly reduced substances, and excessive amounts of nitrogen have the potential of using up potassium persulfate before all nitrogen products have been oxidized.
- 4.2 Suspended matter in the sample will scatter light as it passes through the cuvette to the detector. High blank responses will result. The identified sample will be reanalyzed.
- 4.3 Blemishes in the cuvette, as result of the manufacturing process, will result in high blank responses. The identified sample will be reanalyzed.

5 SAFETY

- 5.1 Safety precautions must be taken when handling reagents, samples and equipment in the laboratory. Protective clothing including lab coats, safety glasses and enclosed shoes must be worn. In certain situations, it will be necessary to also use gloves and/or a face shield. If solutions come in contact with eyes, flush with water continuously for 15 minutes. If solutions come in contact with skin, wash thoroughly with soap and water. Contact Solomons Rescue Squad (911) if emergency treatment is needed and also inform the CBL Associate Director of Administration and Facilities Maintenance of the

incident. Contact the CBL Associate Director of Administration and Facilities Maintenance if additional treatment is required.







5.2 The toxicity or carcinogenicity of each reagent used in this procedure may not have been fully established. Each chemical should be regarded as a potential health hazard and exposure should be as low as reasonably achievable.





Cautions are included for known hazardous materials and procedures.

5.3 Do not wear jewelry when troubleshooting electrical components. Even low voltage points are dangerous and can injure if allowed to short circuit.

5.4 The following hazard classifications are listed for the chemicals used in this procedure. Detailed information is provided on Material Safety Data Sheets (MSDS).

Table 1

Chemical	Health Hazard	Fire Hazard	Instability Hazard	Specific Hazard	
Sodium Hydroxide	3	0	1	ALK, COR	
Potassium hydroxide	3	0	2		
Potassium phosphate	2	0	0		
Sulfanilamide	1	1	0		
N-1-naphthylethylenediamine dihydrochloride	1	0	0		
Nitrate Reductase (AtNaR2) from <i>Arabidopsis thaliana</i>	0	0	0		
NADH (β-Nicotinamide adenine dinucleotide reduced form disodium salt)	0	0	0		
Hydrochloric Acid	3	0	2	ACID, COR	
Potassium nitrate	1	0	0	OXY	
Sodium nitrite	2	0	1		

Chloroform	3	0	0		
Potassium Persulfate	2	0	2	OXY	
Boric Acid	2	0	0		
Glutamic Acid	0	0	0		
Sodium hypochlorite (Clorox)	3	0	0		
EDTA (Ethylenediamine tetraacetic acid)	1	0	0		

On a scale of 0 to 4 the substance is rated on four hazard categories: health, flammability, reactivity, and contact. (0 is non-hazardous and 4 is extremely hazardous)

HAZARD RATING

Health Hazard - Blue: 4 – deadly, 3 – extreme danger, 2 – hazardous, 1 – slightly hazardous, 0 – normal material

Fire Hazard - Red: Flash Points: 4 – below 73° F, 3 – below 100° F, 2 – below 200° F, 1 – above 200° F, 0 – will not burn

Instability Hazard - Yellow: 4 – may detonate, 3 – Shock and heat may detonate, 2 – violent chemical change, 1 – unstable is heated, 0 - stable

Specific Hazard - White: Acid = ACID, Alkali = ALK, Corrosive = COR, Oxidizer = OXY

6 EQUIPMENT AND SUPPLIES

- 6.1 Aquakem 250 multi-wavelength automated discrete photometric analyzer. Aquakem 250 control software operates on a computer running Microsoft Windows NT,XP, or 7 operating system.
- 6.2 Freezer, capable of maintaining $-20 \pm 5^{\circ} \text{C}$.
- 6.3 Lab ware – All reusable lab ware (glass, Teflon, plastic, etc) should be sufficiently clean for the task objectives. This laboratory cleans all lab ware related to this method with a 10% HCl (v/v) acid rinse. Test tubes used in this analysis are predigested and rinsed with copious amounts of reagent water.
- 6.4 Pressure Cooker with pressure regulator and pressure gauge.
- 6.5 Hot plate with variable heat settings.

7 REAGENTS AND STANDARDS

7.1 Purity of Water – Unless otherwise indicated, references to water shall be understood to mean reagent water conforming to Specification D 1193, Type I. Freshly prepared water should be used for making the standards intended for calibration. The detection limits of this method will be limited by the purity of the water and reagents used to make the standards.

7.2 Purity of Reagents – Reagent grade chemicals shall be used in all tests. Unless otherwise indicated, it is intended that all reagents shall conform to specifications of the Committee on Analytical Reagents of the American Chemical Society, where such specifications are available. Other grades may be used, provided it is first ascertained that the reagent is of sufficiently high purity to permit its use without compromising the accuracy of the determination.

7.3 Ethylenediamine tetraacetic acid (EDTA, 25 mM) 9.3 g
In a 1 L volumetric flask add approximately 800 mL reagent water. Dissolve 9.3 g ultrapure EDTA in reagent water and bring to volume. Write name of preparer, preparation date, reagent manufacturer, manufacturer's lot number in the Analytical Reagent log book. Store the flask at room temperature out of direct sunlight. The reagent is stable for one year.

7.4 Phosphate Buffer-

Potassium di-hydrogen phosphate (KH ₂ PO ₄)	1.88 g
Potassium hydroxide (KOH)	0.7 g
EDTA (0.25 M)	5.0 mL

In a 500mL volumetric flask dissolve 1.88 g KH₂PO₄, 0.7g KOH and 5.0 mL EDTA (0.25M) in approximately 400 mL reagent water. Bring flask to 500 mL volume. Store the flask at room temperature. Write name of preparer, preparation date, reagent manufacturers, manufacturers' lot numbers in the Analytical Reagent log book. The reagent is stable for six months.

7.5 Nitrate Reductase (AtNaR2)-

Nitrate reductase from <i>Arabidopsis Thaliana</i>	3.0 unit vial
Phosphate Buffer	20 mL

Transfer 1mL phosphate buffer to the 3.0 unit vial of AtNaR2 to affect dissolution. Shake several times over a thirty minute period. Transfer this to the 20mL reagent bottle quantitatively with four 1 ml aliquots of the phosphate buffer. Add 15mL of phosphate buffer to the reagent bottle. Shake bottle to complete the reagent preparation. This is enough reagent for approximately 300 analyses. Write name of preparer, preparation date, reagent manufacturers, manufacturers' lot numbers in the Analytical Reagent log book. This reagent is stable for eight hours in the refrigerated reagent compartment of the instrument.

7.6 NADH-

(β -Nicotinamide adenine dinucleotide reduced form disodium salt)

Phosphate Buffer

	2.4 g vial
	11 mL

Carefully transfer NADH crystals from vial to 20 mL reagent bottle. Place 1 mL phosphate buffer in vial and shake thoroughly. Transfer to reagent bottle. Add 10 mL phosphate buffer to the reagent bottle. Shake to complete reagent preparation. This is enough reagent for approximately 300 analyses. Write name of preparer, preparation date, reagent manufacturers, manufacturers' lot numbers in the Analytical Reagent log book. This reagent is stable for eight hours in the refrigerated reagent compartment of the instrument.

7.7 Sulfaniamide-

Sulfanilamide	5 g
Hydrochloric Acid (concentrated)	150 mL

Add 250 mL reagent water to a 500 mL volumetric flask. Carefully add 150 mL concentrated hydrochloric acid to the flask. Then add 5 g sulfanilamide to the flask. Bring the flask to volume with reagent water. Once dissolution is complete transfer reagent to a brown poly-bottle and store in the refrigerator. Write name of preparer, preparation date, reagent manufacturers, manufacturers' lot numbers in the Analytical Reagent log book. This reagent is stable for six months.

7.8 N-1-naphthylethylenediamine dihydrochloride –

N-1-naphthylethylenediamine dihydrochloride	0.5 g
---	-------

Place 0.5 g N-1-naphthylethylenediamine dihydrochloride in a 500 mL volumetric flask. Bring flask to volume with reagent water. Once dissolution is complete transfer reagent to a brown poly-bottle and store in refrigerator. Write name of preparer, preparation date, reagent manufacturer, manufacturer's lot number in the Analytical Reagent log book. This reagent is stable for six months.

7.9 Nitrate Stock Standard, 5000 μ M –

Potassium nitrate (KNO ₃), primary standard grade, dried at 45°C	0.253 g
Reagent water	up to 500 mL

In a 500 mL volumetric flask, dissolve 0.253 g of potassium nitrate in ~400 mL of reagent water. Dilute to 500 mL with reagent water (1 mL contains 5 μ moles N). Write the name of preparer, preparation date, reagent manufacturer, manufacturer lot number in the Analytical Standard log book. Make fresh every 6 months or when < 20% remains in bottle.

7.10 Working Nitrate Standard for TDN – See Appendix 1 for all working Nitrate Standards for TDN.

Write the name of preparer, preparation date, reagent manufacturer, manufacturer lot number in the Analytical Standard log book. Make fresh for every digestion batch.

7.11 Stock Nitrite Standard –

Sodium nitrite (NaNO_2), primary standard grade, dried at 45°C

0.1725 g

In a 500mL volumetric flask, dissolve 0.1725 g of sodium nitrite in approximately 400 mL of reagent water. Dilute to volume with reagent water (1 mL contains 5 $\mu\text{moles N}$). Add 1 mL of chloroform as a preservative. Write name of preparer, preparation date, standard manufacturer, manufacturer lot number in the Analytical Standard log book. Make fresh every 6 months or when <20% remains in bottle.

7.12 Secondary Nitrite Standard –

Stock Nitrite Standard

1.0 mL

Reagent water

up to 100 mL

In a volumetric flask, dilute 1.0 mL of Stock Nitrite Standard to 100 mL with reagent water to yield a concentration of 50 $\mu\text{M NO}_2\text{-N/L}$ (0.70 mg N/L). Write the name of preparer, preparation date, reagent manufacturer, manufacturer lot number in the Analytical Standard log book. Make fresh every 4 weeks.

7.13 Glutamic Acid Stock Standard, –

Glutamic Acid dried at 45°C

0.3705 g

Reagent water

up to 500 mL

Chloroform (CHCl_3)

0.5 mL

In a 500 mL volumetric flask, dissolve 0.3705 g of glutamic acid in about 400 mL of reagent water and dilute to 500 mL with reagent water. Add 0.5 mL of chloroform as a preservative. Write the name of preparer, preparation date, reagent manufacturer, manufacturer lot number in the Analytical Standard log book.

7.14 Working Glutamic Acid Standard for TDN – See Appendix 1 for all working Glutamic Acid Standards for TDN.

Write the name of preparer, preparation date, reagent manufacturer, manufacturer lot number in the Analytical Standard log book. Make fresh for every digestion batch.

7.15 Potassium Persulfate Digestion Reagent –

Sodium Hydroxide (NaOH)

3 g

Potassium Persulfate ($\text{K}_2\text{S}_2\text{O}_8$), Low N

20.1 g

Reagent water

up to 1000 mL

In a 1000 mL volumetric flask, dissolve 3g of sodium hydroxide and 20.1 g of potassium persulfate in ~800mL of reagent water. Dilute to 1000 mL with reagent water. Write the name of preparer, preparation date, reagent manufacturer, manufacturer lot number in the Analytical Reagent log book. Make fresh daily. See Appendix 1 for Targeted Watershed Samples (TWS).

7.16 Borate Buffer Solution –

Boric Acid (H ₃ BO ₃)	61.8 g
Sodium Hydroxide (NaOH)	8 g
Reagent water	up to 1000 mL

In a 1000 mL volumetric flask, dissolve 61.8 g of boric acid in ~ 300mL reagent water. Add 8g of sodium hydroxide and dilute to 1000mL with reagent water. Write the name of preparer, preparation date, reagent manufacturer, manufacturer lot number in the Analytical Reagent log book. Make fresh every 4 months.

7.17 Aquakem Cleaning Solution –

Clorox	55.0 mL
--------	---------

In a 100 mL volumetric flask, dilute 55.0 mL of Clorox to volume with 45 mL reagent water to yield a concentration of 75% Clorox. Write name of preparer, preparation date, reagent manufacturer, manufacturer lot number in the Analytical Reagent log book. Reagent is stable for six months.

8 SSAMPLE COLLECTION, PRESERVATION, AND STORAGE

8.1 Water collected for TDN should be filtered through a Whatman GF/F glass fiber filter (nominal pore size 0.7 μm), or equivalent.

8.2 Prior to initial use, capped 30 mL test tubes must be digested with Digestion Reagent, then rinsed thoroughly with reagent water.

8.3 A prescribed amount (typically 10mL) of sample should be added to each sample rinsed, capped 30mL test tube.

8.4 Water collected for TDN should be frozen at ≤-20° C.

8.5 Frozen TDN samples may be stored longer than 28 days. It has been shown that frozen QCS samples up to a year old still fall well within the control limits.

8.6 Digested TDN samples may be stored up to three months.

8.7 TDN samples may be refrigerated at 4° C for no longer than one day.

9 QUALITY CONTROL

9.1 The laboratory is required to operate a formal quality control (QC) program.

The minimum requirements of this program consist of an initial demonstration of laboratory capability and the continued analysis of laboratory instrument blanks and calibration standard material, analyzed as samples, as a continuing

check on performance. The laboratory is required to maintain performance records that define the quality of data generated.

9.2 Initial Demonstration of Capability

- 9.2.1 The initial demonstration of capability (iDOC) – is used to characterize instrument performance (MDLs) and laboratory performance (analysis of QC samples) prior to the analyses conducted by this procedure.
- 9.2.2 Quality Control Sample (QCS/SRM) – When using this procedure, a quality control sample is required to be analyzed during the run, to verify data quality and acceptable instrument performance. If the determined concentrations are not within $\pm 3s$ of the certified values, performance of the determinative step of the method is unacceptable. The source of the problem must be identified and corrected before either proceeding with the initial determination of MDLs or continuing with analyses.
- 9.2.3 Method Detection Limits (MDLs) – MDLs should be established for TDN using a low level natural water sample, typically three to five times higher than the estimated MDL. To determine the MDL values, analyze seven replicate aliquots of water. Perform all calculations defined in the procedure (Section 13) and report the concentration values in the appropriate units. Calculate the MDL as follows:

$$\text{MDL} = S t_{(n-1, 1-\alpha=0.99)}$$

Where,

S = Standard deviation of the replicate analyses.

n=number of replicates

$t_{(n-1, 1-\alpha=0.99)}$ = Student's *t* value for the 99%

confidence level with n-1 degrees of freedom

($t=3.14$ for 7 replicates.)

9.3 MDLs should be determined annually, whenever there is a significant change in instrumental response or a significant change in instrument configuration. Assessing Laboratory Performance

- 9.3.1 Laboratory Reagent Blank (LRB) – The laboratory must analyze at least one LRB with each batch of samples. The LRB consists of reagent water treated the same as the samples. An amount of analyte above the MDL (TDN) found in LRB indicates possible reagent or laboratory environment contamination. LRB data are used to assess and correct contamination from the laboratory environment.
- 9.3.2 Quality Control Sample (QCS)/ Standard Reference Material (SRM) – When using this procedure, a quality control sample is required to be analyzed at the beginning of the run and end of the run, to verify data quality and acceptable instrument performance. If the determined concentrations are not within $\pm 3s$ of the certified values, performance of the determinative step of the method is unacceptable.

The source of the problem must be identified and corrected before either proceeding with the initial determination of MDLs or continuing with the analyses. The results of these QCS/SRM samples shall be used to determine sample batch acceptance.

- 9.3.3 The QCS are obtained from a source external to the laboratory and different from the source of calibration standards.
- 9.3.4 Control Charts – The Accuracy Control Chart for QCS/SRM samples and digested reagent blanks is constructed from the average and standard deviation of the 20 most recent QCS/SRM measurements. The accuracy chart includes upper and lower warning levels ($WL=\pm 2s$) and upper and lower control levels ($CL=\pm 3s$). These values are derived from stated values of the QCS/SRM. The standard deviation (s) is specified relative to statistical confidence levels of 95% for WLs and 99% for CLs. Enter QCS/SRM results on the chart each time the sample is analyzed
- 9.3.5 Calibration Verification, Initial and Continuing (ICV/CCV) – Following every 18-23 samples, two CCV are analyzed to assess instrument performance. The CCVs are made from the different material than the calibration standards (KNO_3), and are to be within the expected value $\pm 3s$. Failure to meet the criteria requires correcting the problem, including reanalysis of any affected samples. If not enough sample exists, the data must be qualified if reported. Specific CCV's can be found in Appendix 1.

9.4 Assessing Analyte Recovery - Percent Recovery

- 9.4.1 Analyte recovery is assessed through percent recoveries of laboratory spikes. Analyte recovery is also assessed through the percent recovery of an organic standard that was digested with each batch of samples.
- 9.4.2 Percent Recovery = (Actual/Expected) x 100

9.5 Assessing Analyte Precision – Relative Percent Difference (RPD)

- 9.5.1 Analyte replication is assessed through duplicate analyses of samples – Relative Percent Difference.
- 9.5.2 $RPD = (Laboratory\ Duplicate\ Result\ 1 - Laboratory\ Duplicate\ Result\ 2) / [(Laboratory\ Duplicate\ Result\ 1 + Laboratory\ Duplicate\ Result\ 2) / 2] \times 100$

9.6 Corrective Actions for Out of Control Data

- 9.6.1 Control limit – If one measurement exceeds Accuracy Control Chart CL, repeat the analysis immediately. If the repeat measurement is within the CL, continue analyses; if it exceeds the CL, discontinue analyses and correct the problem.
- 9.6.2 Warning limit – If two out of three successive points exceed Accuracy Control Chart WL, analyze another sample. If the next

- point is within WL, continue analyses; if the next point exceeds the WL, evaluate potential bias and correct the problem.
- 9.6.3 Trending – If seven successive Accuracy Control Chart measurements are on the same side of the central line, discontinue analyses and correct the problem.
 - 9.6.4 When external QCS samples are out of control, correct the problem. Reanalyze the samples analyzed between the last in-control measurement and the out-of-control one.
 - 9.6.5 When external CCV samples are out of control, correct the problem. Reanalyze the samples analyzed between the last in-control measurement and the out-of-control one.

9.7 General Operation - To assure optimal operation and analytical results, the Reagent Blank (LRB) and CCV are tracked daily in the raw data file, copied to Reagent Blank (LRB) and CCV Control Charts.

Table 2

QC Indicator	Acceptance/ Action Limits	Action	Frequency (Batch)
Correlation Coefficient	≥ 0.998	If <0.998 , evaluate data points of the calibration curve. If any data point is outside established limits, reject as outlier.	1 per batch if acceptable.
Quality Control Sample (QCS)/ Certified Reference Material (CRM)	$\pm 10\%$	If QCS value is outside $\pm 10\%$ of the target value reject the run, correct the problem and rerun samples.	Beginning of run and at end of run.
Initial Calibration Verification (ICV)	$\pm 10\%$	Recalibrate if outside acceptance limits.	Beginning of run following standard curve.
Continuing Calibration Verification (CCV)	$\pm 10\%$	If outside 10%, correct the problem. Rerun all samples following the last in-control CCV.	After every 18-23 samples.
Method Blank/Laboratory Reagent Blank (LRB)	\leq Method Quantitation Limit	If the LRB exceeds the quantitation limit, results are suspect. Rerun the LRB. If the concentration still exceeds the quantitation limit, reject or qualify the data, or raise the quantitation limit.	Following the ICV and after every 18-23 samples following the CCV.

Laboratory Fortified Sample Matrix Spike	± 10%	If the recovery of any analyte falls outside the designated acceptance limits and the QCS is in control, the recovery problem is judged matrix induced. Repeat the LFM and if the sample results are again outside the acceptable recovery range, the sample should be reported with a “matrix induced bias” qualifier.	1/10 (spike OR duplicate)
Laboratory Duplicate	± 10%	If the RPD fails to meet the acceptance limits, the samples should be reanalyzed. If the RPD again fails to meet the acceptance limits, the sample must be reported with a qualifier identifying the sample analysis result as not having acceptable RPD for duplicate analysis.	1/10 (spike OR duplicate)

10 CALIBRATION AND STANDARDIZATION

- 10.1 Calibration – Daily calibration must be performed before sample analysis may begin. Multiple point calibrations (See TAppendix 1) are used with the Aquakem 250. ASTM Type I digested water (reagent water) is used as the zero point in the calibration.
- 10.2 Working TDN Standards – See Appendix 1 for all working TDN Standards.
- 10.3 The instrument software prepares a standard curve for each set of calibrators. A graph plotting measured absorbance against standard concentration is presented for review and approval. If acceptance criteria are not met the entire curve can be reanalyzed or individual standards can be reanalyzed. One standard value (original or reanalyzed) for each and every standard is incorporated in the curve. The coefficient of determination (Pearson’s r value) for the calibration curve as well as the calculated concentration of each calibrator is reviewed. The calculated value of each calibrator must be within ten percent of the expected value. The coefficient of determination (Pearson’s r value) for the calibration curve must be greater than 0.998.

11 PROCEDURE – DAILY OPERATIONS QUALITY CONTROL

- 11.1 Turn on computer. Computer will automatically initiate Konelab software. Once software is running, turn on instrument and allow connection between instrument and computer to complete.
 - 11.2 Discard any water remaining in the water reservoir from the previous analytical run. Fill the water reservoir with fresh reagent water.
 - 11.3 Organize and label cups for samples to be analyzed. Begin daily bench sheet documentation. Remove nitrate reductase and NADH vials from freezer.
 - 11.4 Once water reservoir is full, use instrument software to click More, Instrument Actions, and Perform Water Wash. Complete at least five perform water wash cycles.
 - 11.5 After performing water washes, clean the dispensing needle by performing test washes. Click More, Instrument Actions, More, Adjustment Program. Once in the Adjustment Program click, 4-Dispensing Unit, 1-Dispenser, 8-Test Wash. Perform 8 to 10 Test Washing. When complete, press "Q" to quit until you are able to bring up the Main Page.
 - 11.6 Perform Start Up operations by clicking Start Up at the bottom of the Main Page.
 - 11.7 Gather reagents from refrigerator during start-up and assess reagents. Remake anything that has exceeded the time over which it is considered stable. Nitrate reductase and NADH reagents are made fresh for every analytical run.
 - 11.8 Once startup is complete, check the instrument water blank by clicking More, Instrument Actions, More, Check Water Blank. If any of the instrument blanks are outside their predefined and software controlled limits, the user will be notified on the main menu page. User takes corrective action to return instrument functions to controlled limits.
 - 11.9 Load reagents into reagent carousel and place into refrigerated reagent compartment. Reagent positions can be found by clicking reagents at the top of the main page.
 - 11.10 Load working standards into a sample segment, identify the standards in their positions from the drop down menus at the individual segment positions, and load into instrument. (Click Samples from the top of the Main Page, then click desired segment number.)
 - 11.11 Select the methods to be calibrated by clicking Calibr./QC Selection on the bottom of the main page.. See Appendix 1 for the method to be calibrated. Click Calibrate at the bottom of the page. The three methods will now show as pending. Return to the main page. 11.12 Start the instrument and begin calibration by clicking Page Up on the keyboard. This may also be a green button on the keyboard – See test flow below for stepwise instrument functions for the analysis of standards and samples.
- Test Flow – Method of Analysis, Stepwise
- 55 µL NiR AtNaR to cuvette
 - 5 µL sample to cuvette with mixing
 - 15 µL NiR NADH to cuvette with mixing

- Incubation, 600 seconds, 37°C
- 25 µL sulfanilamide (SAN) reagent to cuvette with mixing
- Incubation, 120 seconds, 37°C
- 25 µL N-1-Naphthylethylenediamine dihydrochloride (NED) reagent to cuvette with mixing
- Incubation, 120 seconds, 37°C
- End point absorbance measurement, 540 nm
- Side-wavelength measurement, 700 nm
- Software processes absorbance value, side wave length value and uses calibration curve to calculate analyte concentration (mg/L N as NO₂)
- User is notified if any measured values used to calculate final concentration are outside preset limits. If so, analyst has options to accept the results, rerun the sample or rerun the sample diluted to a user or software specified factor.
- User is notified of each side wave length value. Side wave length >0.005 absorbance units indicates a scratched cuvette or turbid sample. If the side wave length value exceeds 0.005 absorbance units, the analyst specifies that the sample is reanalyzed. If the side wave length of the reanalyzed sample is <0.005 absorbance units, the reanalyzed result is accepted. If the same concentration and side wave length >0.005 absorbance units is again obtained, the results are accepted.

11.12 Organize and sub-sample into cups the samples, reagent blanks, check standards and all quality control samples while instrument performs calibrations.

11.13As calibration curves are produced by the instrument, review them for acceptability. The instrument software prepares a standard curve for each set of calibrators. A graph plotting measured absorbance against standard concentration is presented for review and approval. If acceptance criteria are not met, either the entire curve shall be reanalyzed or individual standards shall be reanalyzed, depending on the violation. One standard value (original or reanalyzed) for each and every calibrator is incorporated in the curve.

11.14 Once the calibration curve is accepted, samples are loaded into the segments and analyzed. CCV (Continuing Calibration Verification) samples follow every 18-23 samples. Standard Reference Material (SRM) samples, as well as Laboratory Reagent Blanks (LRB) are scattered throughout the analytical batch. Throughout the analytical batch, samples are chosen as laboratory duplicates and laboratory spikes to assess analytical precision and analyte recovery, respectively. The total number of duplicates and spikes performed will be equal to or greater than to ten percent of the total number of samples in the analytical batch.

11.15 As sample analysis is complete, results must be reviewed and accepted manually. If results fall outside acceptance limits, the sample should be reanalyzed. If sample result exceeds the highest standard of the highest calibration range, the samples are automatically diluted by the instrument and reanalyzed.

11.16 Upon completion of all analysis, results are saved to a daily report file. Click Report on the bottom of the main page, More, Results To File, and select one row per result. The file is then named by the run date. The daily report file for analytical batch of July 1, 2015 would be named 070115. The file is converted to Microsoft Excel for data work up. Remaining samples are discarded.

11.17 All reagents are removed from the reagent chamber and returned to the refrigerator. Reagents that have exceeded their stability period are discarded.

11.18 Click on Stand By on the bottom of the main page and insert Aquakem Cleaning Solution is inserted into the instrument. This initiates shut down procedures. Daily files are cleared from the instrument software by clicking More, Management, Clear Daily Files. The software is exited and the instrument is turned off. The computer is turned off.

11.19 The waste is flushed down the drain with copious amounts of tap water. The waste cuvette box is moved to the fume hood and covered. The incubator cover plate is removed. The incubator is wiped clean. The cover is cleaned and returned to its original position.

12 PROCEDURE – SAMPLE DIGESTION

12.1 TDN/TDP samples are digested simultaneously in the same ampule. In our procedures, this ampule is a 30 mL screw cap test tube. (See Appendix 1 for all TWS samples.)

12.2 Prepare working standards, QCS (CRM), and CCV in labeled 100 mL volumetric flasks:

12.2.1 Select concentration range for both TDN/TDP that best fits the sample batch from Appendix 1.

12.2.2 Fill 100 mL volumetric flasks with 80 mL reagent water.

12.2.3 Add appropriate amount of KNO_3 stock standard and KH_2PO_4 secondary standard solution to each labeled working standard volumetric flask from Appendix 1.

12.2.4 Add appropriate amount of glutamic acid and glycerophosphate working standard solutions to each labeled CCV and percent recovery volumetric flask from Appendix 1.

12.2.5 Bring up to 100 mL volume with reagent water.

12.2.6 Mix each 100 mL labeled volumetric flask thoroughly

12.3 Sub-sample working standards into 30mL screw cap test tubes:

12.3.1 Prepare 2, 30mL labeled test tubes for each working standard concentration.

12.3.2 Sample rinse each test tube with the appropriate working standard.

12.3.3 Add exactly 10mL of each working standard to each test tube.

- 12.3.4 Prepare 2 labeled test tubes with exactly 10 mL reagent water for the zero point in the calibration curve.
 - 12.3.5 Set aside 2 empty labeled test tubes to be digested with the batch with digestion reagent only (labeled RB).
 - 12.3.6 Prepare 2, 30mL labeled test tubes for glutamic/glycerophosphate for percent recovery and CCV by adding exactly 10mL to each test tube.
 - 12.3.7 Thaw a Quality Control Sample (CRM) stored in freezer and sub-sample exactly 10mL into a labeled 30mL test tube to be used for QCS.
- 12.4 Prepare Digestion Reagent by dissolving 20.1 g Potassium persulfate and 3 g Sodium hydroxide in a 1000 mL volumetric flask:
- 12.4.2 Rinse volumetric flask with reagent water.
 - 12.4.3 Add 20.1 g Potassium Persulfate directly to the volumetric flask.
 - 12.4.4 Add reagent water until the meniscus is slightly below full volume.
 - 12.4.5 Add 3 g Sodium Hydroxide to the persulfate and water solution, cap immediately and mix thoroughly.
 - 12.4.6 Bring to volume with reagent water.
 - 12.4.7 Make fresh daily.
 - 12.4.8 Digestion Reagent has a shelf life of about 4 hours.
- 12.5 When ready to digest, thaw frozen samples at room temperature.
- 12.6 Rinse dispensing vessel with reagent water and sample rinse with digestion reagent.
- 12.7 Add thoroughly mixed digestion reagent.
- 12.8 Adjust and check dispensing vessel for desired dispensing volume.
- 12.9 Add desired amount of digestion reagent (Typically 5mL), cap tube, shake for mixing and add test tube to pressure cooker.
- 12.10 Add desired amount of digestion reagent (5mL) to the standards at the beginning, middle and end of the sequence of loading the samples.
- 12.11 When all samples and standards have received digestion reagent and have been loaded into the pressure cooker, place pressure cooker on hot plate, add reagent water until tubes are 75% immersed, wet the gasket on the lid with a few drops of water and place lid on the pressure cooker.
- 12.12 Turn the hot plate on maximum temperature and have the pressure cooker come up to full steam. (This takes about 1 hour.)
- 12.13 When full steam is achieved, place the pressure regulator on the steam vent. Maintain heat for the cooker containing samples and standards at 3-4 psi for 55 minutes.
- 12.14 Turn off pressure cooker and unplug the hot plate when finished. Keep the lid on the pressure cooker.

12.15 After samples have cooled, usually the next day, remove the pressure cooker lid, add 1 mL Borate Buffer to each tube, cap, and shake.

12.16 Sample batch is now ready to analyze and is stable for 3 months.

13 DATA ANALYSIS AND CALCULATIONS

13.1 Upon completion of all analysis, results are saved to a daily report file. The file is named by the run date. The daily report file for analytical batch of July 1, 2015 would be named 070115. The file is converted to Microsoft Excel and then to Lotus 123 for data work up. The instrument software has calculated final sample concentration from the designated standard curve, correcting each concentration for associated side wave length and also for any user or instrument specified dilution. Dilution by the instrument is noted by software as analysis ensues and, also, documented in the Excel data report file. The analyst examines each row of data. Results are eliminated that are outside the limits of the calibration range, or have an unrepeatable side wave length measurement greater than 0.005 absorbance units.

14 REFERENCES

- 14.1 USEPA. 1979. Method No. 353.2 *in* Methods for chemical analysis of water and wastes. United States Environmental Protection Agency, Office of Research and Development. Cincinnati, Ohio. Report No. EPA-600/4-79-020 March 1979. 460pp.
- 14.2 Campbell, et al. (2006). Nitrate reductase for nitrate analysis in water. *Environ Chem Letters* 4:69. <http://www.nitrate.com/ECL2006.pdf>
- 14.3 Frank, J. M., C.F. Zimmermann and C. W. Keefe (2006). Comparison of results from Konelab Aquakem 250 and existing nutrient analyzers. UMCES CBL Nutrient Analytical Services Laboratory, Dec. 2006.
- 14.4 Patton, et al. (2002). Corn leaf nitrate reductase – a nontoxic alternative to cadmium for photometric nitrate determinations in water samples by air-segmented continuous-flow analysis, *Environ. Sci Tech.* 2002, 36, 729-735. <http://www.nitrate.com/pattonetal2002.pdf>
- 14.5 <http://www.nitrate.com/nar-nam1.htm>

Range	umoles NO3/L	mg N/L	ml 1 NO3 std/100ml	Potassium Persulfate	Spike Conc.	Glutamic/Glycerophosphate for % Recovery	CCV
	0	0	DI H2O				
Low	10	0.14	0.2	20.1 g/L and 3g/L NaOH	200 umole NO3	1 ml Glutamic	1.0 mL Glutamic
10 ml sample	25	0.35	0.5		12 umole PO4		
5 ml persulfate	35	0.49	0.7				
	50	0.70	1.0				
	75	1.05	1.5				
XHigh	0	0	DI H2O		400 umole NO3	3 ml Glutamic	3.0 mL Glutamic
10 ml sample	25	0.35	0.5	20.1 g/L and 3g/L NaOH	12 umole PO4		
5 ml persulfate	50	0.70	0.7				
	75	1.05	1.5				
	100	1.4	2.0				
	150	2.1	3.0				
	200	2.8	4.0				
	400	5.6	8.0				
TWS TDN	0	0	DI H2O				4 ml Glutamic
5 ml sample	150	2.1	3.0	13.4 g/2000 mL and 2 g NaOH	2.5 ml of		
15 ml persulfate	300	4.2	6.0	6.7 g/L and 1g NaOH	400 umole NO3 & 12 umole PO4		
	400	5.6	8.0		Added to 2.5 ml sample prior to digestion		
	500	7.0	10.0				

Appendix 1. Methods and Standards Used for TDN Enzyme Catalyzed Nitrate

UNIVERSITY OF MARYLAND CENTER FOR ENVIRONMENTAL SCIENCE
CHESAPEAKE BIOLOGICAL LABORATORY
NUTRIENT ANALYTICAL SERVICES LABORATORY
146 Williams St., Solomons MD 20688
<http://nasl.cbl.umces.edu/>

**Standard Operating Procedure for
Determination of Total Dissolved Nitrogen (TDN) and Total Nitrogen (TN) in
Fresh/Estuarine/Coastal Waters Using Alkaline Persulfate Digestion of Nitrogen to
Nitrate and Measured Using Cadmium Reduction
(References EPA 353.2, Standard Methods #4500-N C, 4500-NO3 F)**

**Revision 2017-1
Replaces Revision 2015
Effective April 26, 2017**

Revised by: _____ Date: _____

Reviewed by: _____ Date: _____

Laboratory Supervisor: _____ Date: _____

Changes affecting Revision 2015

Section 1.1: Changed Nitrogen to nitrogen

Section 1.3: Inserted If more than seven replicates are used to determine the MDL, refer to the Student's *t* test table for the appropriate n-1 value.

Section 1.7: Used references instead of conforms

Section 2.1: Added (whole water for TN)

Entire Document: Changed Table 1 to Appendix 1

Section 3.5: Deleted preparation batch definition

Section 3.24: Deleted Instrument Detection Limit

Entire Document: Changed deionized water to reagent water

Section 3.25: Changed blank matrix to matrix blank

Section 3.27: Added This is also referred to as MDL.

Section 3.28: Added This is also referred to as the Quantitation Limit

Section 3.37: Changed proscribed to prescribed

Section 3.38: Added Also referred to as CRM

Section 3.45: Added Also referred to as CRM

Section 4.2: Added samples are filtered for TDN

Section 5.1 Changed the word should to must, Changed CBL Business Manager to the CBL Associate Director of Administration and Facilities Maintenance

Section 5.4: Updated Chemical Safety Table (Table 1)

Section 7.6: Changed Color Reagent to be made in 500 ml instead of 1L

Section 7.7: Changed KNO₃ standard to be made in 500 ml instead of 1L, make fresh every 6 months instead of 4

Section 7.10: Changed NaNO₂ standard to be made in 500 ml instead of 1L

Section 8.4: Added ≤ sign for freezer temp

Section 9.2.1: Changed the initial demonstration of capability acronym to Idoc

Section 9.2.2: Changed QCS checks from 10% to 3s

Section 9.2.3: Deleted from MDL description the change of operator or a new matrix is encountered, changed ambient water to natural water

Section 9.3.1: Deleted LRB above the MDL requires that the source of the problem must be identified and corrected before proceeding with analysis

Section 9.3.3: Added the words reagent blanks, deleted Set up an accuracy chart by using percent recovery since the concentration of the QCS/SRM varies

Section 9.3.4: Added ICV information to the CCV, Added See Appendix 1 for additional CCVs,

Changed TV to the expected value

Section 9.3.5: Added REV descriptions

Section 9.4: Changed % to read Percent

Section 9.7: Added Table 2

Section 10.3: Added the coefficient of determination (Pearson's *r* value) for the calibration curve as well as the calculated concentration of each calibrator is reviewed.

The calculated value of each calibrator must be within ten percent of the expected value.

The coefficient of determination (Pearson's *r* value) for the calibration curve must be greater than 0.998

Section 12.7: Added Analyze CRM sample at the beginning of the first group of samples

Section 12.10: Added At the end of the sample run, analyze CRM sample.

Section 12.11: Deleted the REV step at the end of the analytical run

Section 13.3.6: Added labeled RB

Section 13.13: Changed digestion time to 55 minutes

Section 15: Deleted Method Performance section

Determination of Total Dissolved Nitrogen (TDN) and Total Nitrogen (TN) in Fresh/Estuarine/Coastal Waters Using Alkaline Persulfate Digestion of Nitrogen to Nitrate and Measured Using Cadmium Reduction

1. SCOPE and APPLICATION

1.1 Potassium Persulfate is used to oxidize organic and inorganic nitrogen to NO_3 under heated alkaline conditions.

1.2 Cadmium reduction is used to quantitatively reduce dissolved nitrate to nitrite which is then measured by colorimetric quantitative analysis of a highly colored azo dye. The method is used to analyze all ranges of salinity.

1.3 A Method Detection Limit (MDL) of 0.05 mg TDN as $\text{NO}_3\text{-N/L}$ was determined using the Student's t value (3.14, $n=7$) times the standard deviation of a minimum of 7 replicates. If more than seven replicates are used to determine the MDL, refer to the Student's t test table for the appropriate $n-1$ value.

1.4 The Quantitation Limit for TDN as NO_3 was set at 0.15 mg TDN as $\text{NO}_3\text{-N/L}$.

1.5 This procedure should be used by analysts experienced in the theory and application of aqueous organic and inorganic analysis. A three month training period with an analyst experienced in the analysis of TDN in aqueous samples by cadmium reduction is required.

1.6 This method can be used for all programs that require analysis of TDN.

1.7 This procedure references Standard Methods #4500-N C, 4500- NO_3 F and EPA Method 353.2 (1979).

2. SUMMARY

2.1 An exact amount of filtered samples (whole water for TN) are placed in test tubes where an exact amount of Potassium Persulfate Digestion Reagent is added. Under initially alkaline conditions and heat, nitrate is the sole nitrogen product.

2.2 The now digested samples are buffered, then mixed and passed through a granulated copper-cadmium column to reduce nitrate to nitrite. The nitrite, both that which was reduced from nitrate and originally present, is then determined by diazotizing with sulfanilamide and coupling with N-1-naphthylethylenediamine dihydrochloride to form a colored azo dye.

3. DEFINITIONS

3.1 Acceptance Criteria – Specified limits placed on characteristics of an item, process, or service defined in a requirement document. (ASQC)

- 3.2 Accuracy – The degree of agreement between an observed value and an accepted reference value. Accuracy includes a combination of random error (precision) and systematic error (bias) components which are due to sampling and analytical operations; a data quality indicator. (QAMS)
- 3.3 Aliquot – A discrete, measured, representative portion of a sample taken for analysis. (EPA QAD Glossary)
- 3.4 Analytical Range – There are multiple analytical ranges/standard curves used for determination of TDN. See Appendix 1 for all analytical ranges used.
- 3.5 Batch – Environmental samples, which are prepared and /or analyzed together with the same process and personnel, using the same lot(s) of reagents. An **analytical batch** is composed of prepared environmental samples (extracts, digestates, or concentrates) and/or those samples not requiring preparation, which are analyzed together as a group using the same calibration curve or factor. An analytical batch can include samples originating from various environmental matrices and can exceed 20 samples. (NELAC/EPA)
- 3.6 Blank- A sample that has not been exposed to the analyzed sample stream in order to monitor contamination during sampling, transport, storage or analysis. The blank is subjected to the usual analytical and measurement process to establish a zero baseline or background value and is sometimes used to adjust or correct routine analytical results. (ASQC)
- 3.7 Calibrate- To determine, by measurement or comparison with a standard, the correct value of each scale reading on a meter or other device, or the correct value for each setting of a control knob. The levels of the applied calibration standard should bracket the range of planned or expected sample measurements. (NELAC)
- 3.8 Calibration – The set of operations which establish, under specified conditions, the relationship between values indicated by a measuring device. The levels of the applied calibration standard should bracket the range of planned or expected sample measurements. (NELAC)
- 3.9 Calibration Blank – A volume of reagent water fortified with the same matrix as the calibration standards, without the analyte added.
- 3.10 Calibration Curve – The graphical relationship between known values, such as concentrations, or a series of calibration standards and their analytical response. (NELAC)
- 3.11 Calibration Method – A defined technical procedure for performing a calibration. (NELAC)
- 3.12 Calibration Standard – A substance or reference material used to calibrate an instrument. (QAMS)
- 3.12.1 Initial Calibration Standard (STD) – A series of standard solutions used to initially establish instrument calibration responses and develop calibration curves for individual target analytes.

- 3.12.2 Initial Calibration Verification (ICV) – An individual standard, analyzed initially, prior to any sample analysis, which verifies acceptability of the calibration curve or previously established calibration curve.
- 3.12.3 Continuing Calibration Verification (CCV) – An individual standard which is analyzed after every 18-23 field sample analysis.
- 3.13 Certified Reference Material (CRM) – A reference material one or more of whose property values are certified by a technically valid procedure, accompanied by or traceable to a certificate or other documentation which is issued by a certifying body. (ISO 17025)
- 3.14 Colorimeter – Detector found in Bran & Luebbe Single-Channel Industrial Colorimeter. Color is quantitatively detected with 199-B021-01 phototubes using 550 nm monochromatic filters and 50 mm long flow cell with 1.5 mm internal diameter. Comparisons are made between signals from the colored solution in the flow cell to the signal of air in the reference cell. Signals from the Colorimeter are transmitted to a Recorder.
- 3.15 Corrective Action – Action taken to eliminate the causes of an existing nonconformity, defect or other undesirable situation in order to prevent recurrence. (ISO 8402)
- 3.16 Deficiency – An unauthorized deviation from acceptable procedures or practices. (ASQC)
- 3.17 Demonstration of Capability – A procedure to establish the ability of the analyst to generate acceptable accuracy. (NELAC)
- 3.18 Detection Limit – The lowest concentration or amount of the target analyte that can be determined to be different from zero by a single measurement at a stated degree of confidence.
- 3.19 Duplicate Analysis – The analyses of measurements of the variable of interest performed identically on two sub samples (aliquots) of the same sample. The results from duplicate analyses are used to evaluate analytical or measurement precision but not the precision of sampling, preservation or storage internal to the laboratory. (EPA-QAD)
- 3.20 External Standard (ES) – A pure analyte (potassium nitrate (KN O₃)) that is measured in an experiment separate from the experiment used to measure the analyte(s) in the sample. The signal observed for a known quantity of the pure external standard is used to calibrate the instrument response for the corresponding analyte(s). The instrument response is used to calculate the concentrations of the analyte(s) in the unknown sample.
- 3.21 Field Duplicates (FD1 and FD2) – Two separate samples collected at the same time and place under identical circumstances and treated exactly the same throughout field and laboratory procedures. Analyses of FD1 and FD2 provide a measure of the precision associated with sample collection, preservation and storage, as well as with laboratory procedures.

- 3.22 Field Reagent Blank (FRB) – A aliquot of reagent water or other blank matrix that is placed in a sample container in the laboratory and treated as a sample in all respects, including shipment to the sampling site, exposure to the sampling site conditions, storage, preservation, and all analytical procedures. The purpose of the FRB is to determine if method analytes or other interferences are present in the field environment.
- 3.23 Holding time – The maximum time that samples may be held prior to analysis and still be considered valid. (40 CFR Part 136) The time elapsed from the time of sampling to the time of extraction or analysis, as appropriate.
- 3.24 Laboratory Duplicates (LD1 and LD2) – Two aliquots of the same sample taken in the laboratory and analyzed separately with identical procedures. Analyses of LD1 and LD2 indicate precision associated with laboratory procedures, but not with sample collection, preservation, or storage procedures.
- 3.25 Laboratory Reagent Blank (LRB) – A matrix blank (i.e., reagent water) that is treated exactly as a sample including exposure to all glassware, equipment, solvents, and reagents that are used with other samples. The LRB is used to determine if method analytes or other interferences are present in the laboratory environment, the reagents, or the instrument.
- 3.26 Laboratory Control Sample (LCS) – A sample matrix, free from the analytes of interest, spiked with verified known amounts of analytes from a source independent of the calibration standard or a material containing known and verified amounts of analytes. The LCS is generally used to establish intra-laboratory or analyst-specific precision and bias or to assess the performance of all or a portion of the measurement system. (NELAC)
- 3.27 Limit of Detection (LOD) – The lowest concentration level that can be determined by a single analysis and with a defined level of confidence to be statistically different from a blank. This is also referred to as MDL. (ACS)
- 3.28 Limit of Quantitation (LOQ) – The minimum levels, concentrations, or quantities of a target variable (target analyte) that can be reported with a specified degree of confidence. The LOQ is set at 3 to 10 times the LOD, depending on the degree of confidence desired. This is also referred to as the Quantitation Limit.
- 3.29 Linear Dynamic Range (LDR) – The absolute quantity over which the instrument response to an analyte is linear. This specification is also referred to as the Linear Calibration Range (LCR).
- 3.30 Manifold – The module whose configuration of glass connectors, fittings, mixing coils, tubing and Cadmium-Copper reduction column precisely reduces the nitrate in the sample to nitrite, followed by color production.

- 3.31 Material Safety Data Sheets (MSDS) – Written information provided by vendors concerning a chemical’s toxicity, health hazards, physical properties, fire, and reactivity data including storage, spill, and handling precautions.
- 3.32 May – Denotes permitted action, but not required action. (NELAC)
- 3.33 Method Detection Limit (MDL) – The minimum concentration of an analyte that can be identified, measured, and reported with 99% confidence that the analyte concentration is greater than zero.
- 3.34 Must – Denotes a requirement that must be met. (Random House College Dictionary)
- 3.35 Precision – The degree to which a set of observations or measurements of the same property, obtained under similar conditions, conform to themselves; a data quality indicator. Precision is usually expressed as standard deviation, variance or range, in either absolute or relative terms. (NELAC)
- 3.36 Preservation – Refrigeration, freezing, and/or reagents added at the time of sample collection (or later) to maintain the chemical and or biological integrity of the sample.
- 3.37 Proportioning Pump – A peristaltic pump that mixes and advances samples and reagents through prescribed precision pump tubes proportionately for the reactions to take place and for the concentration to be measured.
- 3.38 Quality Control Sample (QCS) – A sample of analyte of known and certified concentration. The QCS is obtained from a source external to the laboratory and different from the source of calibration standards. It is used to check laboratory performance with externally prepared test materials. Also referred to as CRM.
- 3.39 Recorder – A graphic recorder used to record electronic output from the colorimeter.
- 3.40 Run Cycle – Typically a day of operation – the entire analytical sequence from sampling the first standard to the last sample of the day.
- 3.41 Sampler – An automated rotational device that moves sample cups sequentially to aspirate an aliquot into the proscribed analytical stream. As the loaded sample tray rotates, a metal probe dips into the sample cup and aspirates sample for a preset time, rises from the sample cup and aspirates air for approximately one second and goes into a reagent water-filled wash receptacle, where reagent water is aspirated. After another preset interval, the probe rises from the wash receptacle, aspirates air and moves into the next sample cup. The sampler moves at a rate of 40 samples per hour with a sample to wash solution ratio of 9:1.
- 3.42 Sensitivity – The capability of a test method or instrument to discriminate between measurement responses representing different levels (concentrations) of a variable of interest.

- 3.43 Shall – Denotes a requirement that is mandatory whenever the criterion for conformance with the specification requires that there be no deviation. (ANSI)
- 3.44 Should – Denotes a guideline or recommendation whenever noncompliance with the specification is permissible. (ANSI)
- 3.45 Standard Reference Material (SRM) – Material which has been certified for specific analytes by a variety of analytical techniques and/or by numerous laboratories using similar analytical techniques. These may consist of pure chemicals, buffers, or compositional standards. The materials are used as an indication of the accuracy of a specific analytical technique. Also referred to as CRM.

4 INTERFERENCES











- 4.1 Metals, highly reduced substances, and excessive amounts of nitrogen have the potential of using up potassium persulfate before all nitrogen products have been oxidized.
- 4.2 Suspended matter in the sample will restrict flow through the apparatus. All samples must be filtered for TDN. See Section 8.
- 4.3 Concentrations of sulfide, iron, copper or other metals above several milligrams per liter lower reduction efficiency, yielding inaccurate concentrations for those samples and, also, subsequent analyses. Frequent checks of column efficiency and re-analyses of affected samples are necessary.

5 SAFETY

- 5.1 Safety precautions must be taken when handling reagents, samples and equipment in the laboratory. Protective clothing including lab coats, safety glasses and enclosed shoes must be worn. In certain situations, it will be necessary to also use gloves and/or a face shield. If solutions come in contact with eyes, flush with water continuously for 15 minutes. If solutions come in contact with skin, wash thoroughly with soap and water. Contact Solomons Rescue Squad (911) if emergency treatment is needed and also inform the CBL Associate Director of Administration and Facilities Maintenance of the incident. Contact the CBL Associate Director of Administration and Facilities Maintenance if additional treatment is required.
- 5.2 The toxicity or carcinogenicity of each reagent used in this procedure may not have been fully established. Each chemical should be regarded as a potential health hazard and exposure should be as low as reasonably achievable. Cautions are included for known hazardous materials and procedures.

- 5.3 Do not wear jewelry when troubleshooting electrical components. Even low voltage points are dangerous and can injure if allowed to short circuit.
- 5.4 The following hazard classifications are listed for the chemicals used in this procedure. Detailed information is provided on Material Safety Data Sheets (MSDS).

Table 1

Chemical	Health Hazard	Fire Hazard	Instability Hazard	Specific Hazard	
Sodium Hydroxide	3	0	1	ALK, COR	
Copper Sulfate	2	0	0		
Ammonium Chloride	2	0	2		
Sulfanilamide	1	1	0		
N-1-naphthylethylene diamine dihydrochloride	1	0	0		
Brij-35	0	0	0		
Phosphoric Acid	3	0	1	ACID	
Hydrochloric Acid	3	0	2	ACID, COR	
Cadmium	3	0	0		
Potassium nitrate	1	0	0	OXY	
Sodium nitrite	2	0	1	OXY	
Chloroform	3	0	0		
Potassium Persulfate	2	0	2	OXY	
Boric Acid	2	0	0		

Glutamic Acid	0	0	0		
---------------	---	---	---	--	--

On a scale of 0 to 4 the substance is rated on four hazard categories: health, flammability, reactivity, and contact. (0 is non-hazardous and 4 is extremely hazardous)

HAZARD RATING

Health Hazard - Blue: 4 – deadly, 3 – extreme danger, 2 – hazardous, 1 – slightly hazardous, 0 – normal material

Fire Hazard - Red: Flash Points: 4 – below 73° F, 3 – below 100° F, 2 – below 200° F, 1 – above 200° F, 0 – will not burn

Instability Hazard - Yellow: 4 – may detonate, 3 – Shock and heat may detonate, 2 – violent chemical change, 1 – unstable is heated, 0 - stable

Specific Hazard - White: Acid = ACID, Alkali = ALK, Corrosive = COR, Oxidizer = OXY

6 EQUIPMENT AND SUPPLIES

- 6.1 Technicon Bran & Luebbe AutoAnalyzer II sampler (now owned by Seal Analytical), proportioning pump, manifold and colorimeter capable of analyzing for nitrate plus nitrite are used in this laboratory. A PMC Industries Flat Bed Linear recorder is used to record electronic output from the colorimeter.
- 6.2 Freezer, capable of maintaining $-20 \pm 5^{\circ}$ C.
- 6.3 Lab ware – All reusable lab ware (glass, Teflon, plastic, etc) should be sufficiently clean for the task objectives. This laboratory cleans all lab ware related to this method with a 10% HCl (v/v) acid rinse. Test tubes used in this analysis are predigested and rinsed with copious amounts of reagent water.
- 6.4 Pressure Cooker with pressure regulator and pressure gauge.
- 6.5 Hot plate with variable heat settings.

7 REAGENTS AND STANDARDS

- 7.1 Purity of Water – Unless otherwise indicated, references to water shall be understood to mean reagent water conforming to Specification D 1193, Type I. Freshly prepared water should be used for making the standards intended for calibration. The detection limits of this method will be limited by the purity of the water and reagents used to make the standards.
- 7.2 Purity of Reagents – Reagent grade chemicals shall be used in all tests. Unless otherwise indicated, it is intended that all reagents shall conform to specifications of the Committee on Analytical Reagents of the American Chemical Society, where such specifications are available. Other grades may be used, provided it is first ascertained that the reagent is of sufficiently high purity to permit its use without compromising the accuracy of the determination.

7.3 Alkaline Water –

Sodium hydroxide (NaOH, pellets)	0.20±0.02 g
Reagent water	up to 1000 mL

Add 0.20 g of sodium hydroxide pellets to 1000 mL of reagent water. Write the name of preparer, preparation date, reagent manufacturer, manufacturer lot number in the Analytical Reagent log book. The reagent is stable for six months.

7.4 Copper Sulfate Reagent, 2% –

Copper sulfate (CuSO ₄ ·5H ₂ O)	2 g
Reagent water	up to 100 ml

In a 100 mL volumetric flask, dissolve 2 g of copper sulfate in ~80 mL of reagent water. Dilute to 100 mL with reagent water. Write the name of preparer, preparation date, reagent manufacturer, manufacturer lot number in the Analytical Reagent log book. The reagent is stable for six months.

7.5 Ammonium Chloride Reagent –

Ammonium Chloride (NH ₄ Cl)	10 g
Reagent water	up to 1000 mL
Copper Sulfate Reagent, 2%	6 drops
Sodium Hydroxide Pellets	2 pellets

In a 1000 ml volumetric flask, dissolve 10 g of concentrated ammonium chloride to ~800 ml of reagent water. Dilute to 1000 mL with reagent water. Attain a pH balance of 8.5. Add 6 drops of Copper Sulfate Reagent, 2% and 2 pellets NaOH. Write the name of preparer, preparation date, reagent manufacturer, manufacturer lot number in the Analytical Reagent log book. The reagent is stable for six months.

7.6 Color Reagent –

Sulfanilamide (C ₆ H ₈ N ₂ O ₂ S)	10 g
Phosphoric Acid (H ₃ PO ₄), concentrated (80%)	100 mL
N-1-naphthylethylenediamine dihydrochloride (C ₁₂ H ₁₄ N ₂ ·2HCl)	0.5 g
Reagent water	up to 1000 mL
Brij-35, 30%	1 mL

In a 1000 mL volumetric flask, add 100 mL concentrated phosphoric acid and 10 g of sulfanilamide to ~500 mL reagent water. Add 0.5 g of N-1-naphthylethylenediamine dihydrochloride and dissolve. Dilute to 1000 ml with reagent water and add 5 mL of 30% Brij-35. Write the name of preparer, preparation date, reagent manufacturer, manufacturer lot number in the Analytical Reagent log book. Make fresh every 3 months. Store at 4°C.

7.7 Nitrate Stock Standard, 5000 µM –

Potassium nitrate (KNO ₃), primary standard grade, dried at 45°C	0.253 g
Reagent water	up to 500 mL

In a 500 mL volumetric flask, dissolve 0.253 g of potassium nitrate in ~400 mL of reagent water. Dilute to 500 mL with reagent water (1 mL contains 5 μ moles N). Write the name of preparer, preparation date, reagent manufacturer, manufacturer lot number in the Analytical Standard log book. Make fresh every 6 months or when < 20% remains in bottle.

7.8 Secondary Nitrate Standard –

Stock Nitrate Standard	1.0 mL
Reagent water	up to 100 mL

In a volumetric flask, dilute 1.0 mL of Stock Nitrate Standard to 100 mL with reagent water to yield a concentration of 50 μ M NO_3^- /L (0.70 mg N/L). Write the name of preparer, preparation date, reagent manufacturer, manufacturer lot number in the Analytical Standard log book. Make fresh every 4 weeks.

7.9 Working Nitrate Standard for TDN – See Appendix 1 for all working Nitrate Standards for TDN.

Write the name of preparer, preparation date, reagent manufacturer, manufacturer lot number in the Analytical Standard log book. Make fresh for every digestion batch.

7.10 Stock Nitrite Standard –

Sodium nitrite (NaNO_2), primary standard grade, dried at 45°C	0.1725 g
Reagent water	up to 500 mL

In a 500 mL volumetric flask, dissolve 0.1725 g of sodium nitrite in ~400 mL of reagent water. Dilute to 500 mL with reagent water (1 mL contains 5 μ moles N). Add 1 mL of chloroform as a preservative. Write the name of preparer, preparation date, reagent manufacturer, manufacturer lot number in the Analytical Standard log book. Make fresh every 6 months or when < 20% remains in bottle.

7.11 Secondary Nitrite Standard –

Stock Nitrite Standard	1.0 mL
Reagent water	up to 100 mL

In a volumetric flask, dilute 1.0 mL of Stock Nitrite Standard to 100 mL with reagent water to yield a concentration of 50 μ M NO_2^- /L (0.70 mg N/L). Write the name of preparer, preparation date, reagent manufacturer, manufacturer lot number in the Analytical Standard log book. Make fresh every 4 weeks.

7.12 Glutamic Acid Stock Standard, - Glutamic Acid dried at 45°C

0.3705 g

Reagent water	up to 500 mL
Chloroform (CHCl ₃)	0.5 mL

In a 500 mL volumetric flask, dissolve 0.3705 g of glutamic acid in about 400 mL of reagent water and dilute to 500 mL with reagent water. Add 0.5 mL of chloroform as a preservative. Write the name of preparer, preparation date, reagent manufacturer, manufacturer lot number in the Analytical Standard log book.

7.13 Working Glutamic Acid Standard for TDN – See Appendix 1 for all working Glutamic Acid Standards for TDN.

Write the name of preparer, preparation date, reagent manufacturer, manufacturer lot number in the Analytical Standard log book. Make fresh for every digestion batch.

7.14 Potassium Persulfate Digestion Reagent –

Sodium Hydroxide (NaOH)	3 g
Potassium Persulfate (K ₂ S ₂ O ₈), Low N	20.1 g
Reagent water	up to 1000 mL

In a 1000 mL volumetric flask, dissolve 3g of sodium hydroxide and 20.1 g of potassium persulfate in ~800mL of reagent water. Dilute to 1000 mL with reagent water. Write the name of preparer, preparation date, reagent manufacturer, manufacturer lot number in the Analytical Reagent log book. Make fresh daily.

7.15 Borate Buffer Solution –

Boric Acid (H ₃ BO ₃)	61.8 g
Sodium Hydroxide (NaOH)	8 g
Reagent water	up to 1000 mL

In a 1000 mL volumetric flask, dissolve 61.8 g of boric acid in ~ 300mL reagent water. Add 8g of sodium hydroxide and dilute to 1000mL with reagent water. Write the name of preparer, preparation date, reagent manufacturer, manufacturer lot number in the Analytical Reagent log book. Make fresh every 4 months.

8 SAMPLE COLLECTION, PRESERVATION, AND STORAGE

8.1 Water collected for TDN should be filtered through a Whatman GF/F glass fiber filter (nominal pore size 0.7 μm), or equivalent.

8.2 Prior to initial use, capped 30 mL test tubes must be digested with Digestion Reagent, then rinsed thoroughly with reagent water.

8.3 A prescribed amount (typically 10mL) of sample should be added to each sample rinsed, capped 30mL test tube.

8.4 Water collected for TDN should be frozen at ≤-20° C.

8.5 Frozen TDN samples may be stored longer than 28 days. It has been shown that frozen QCS samples up to a year old still fall well within the control limits.

8.6 Digested TDN samples may be stored up to three months.

8.7 TDN samples may be refrigerated at 4° C for no longer than one day.

9 QUALITY CONTROL

9.1 The laboratory is required to operate a formal quality control (QC) program.

The minimum requirements of this program consist of an initial demonstration of laboratory capability and the continued analysis of laboratory instrument blanks and calibration standard material, analyzed as samples, as a continuing check on performance. The laboratory is required to maintain performance records that define the quality of data generated.

9.2 Initial Demonstration of Capability

9.2.1 The initial demonstration of capability (iDOC) – is used to characterize instrument performance (MDLs) and laboratory performance (analysis of QC samples) prior to the analyses conducted by this procedure.

9.2.2 Quality Control Sample (QCS/SRM) – When using this procedure, a quality control sample is required to be analyzed during the run, to verify data quality and acceptable instrument performance. If the determined concentrations are not within $\pm 3s$ of the certified values, performance of the determinative step of the method is unacceptable. The source of the problem must be identified and corrected before either proceeding with the initial determination of MDLs or continuing with analyses.

9.2.3 Method Detection Limits (MDLs) – MDLs should be established for TDN using a low level natural water sample, typically three to five times higher than the estimated MDL. To determine the MDL values, analyze seven replicate aliquots of water. Perform all calculations defined in the procedure (Section 14) and report the concentration values in the appropriate units. Calculate the MDL as follows:

$$MDL = S t_{(n-1, 1-\alpha=0.99)}$$

Where,

S = Standard deviation of the replicate analyses.

n=number of replicates

$t_{(n-1, 1-\alpha=0.99)}$ = Student's *t* value for the 99% confidence level with n-1 degrees of freedom ($t=3.14$ for 7 replicates.)

MDLs should be determined annually, whenever there is a significant change in instrumental response or a significant change in instrument configuration.

9.3 Assessing Laboratory Performance

- 9.3.1 Laboratory Reagent Blank (LRB) – The laboratory must analyze at least one LRB with each batch of samples. The LRB consists of reagent water treated the same as the samples. An amount of analyte above the MDL (TDN) found in LRB indicates possible reagent or laboratory environment contamination. LRB data are used to assess and correct contamination from the laboratory environment.
- 9.3.2 Quality Control Sample (QCS)/ Standard Reference Material (SRM) – When using this procedure, a quality control sample is required to be analyzed at the beginning of the run and end of the run, to verify data quality and acceptable instrument performance. If the determined concentrations are not within $\pm 3s$ of the certified values, performance of the determinative step of the method is unacceptable. The source of the problem must be identified and corrected before either proceeding with the initial determination of MDLs or continuing with the analyses. The results of these QCS/SRM samples shall be used to determine sample batch acceptance.
- 9.3.3 The QCS are obtained from a source external to the laboratory and different from the source of calibration standards.
- 9.3.4 Control Charts – The Accuracy Control Chart for QCS/SRM samples and digested reagent blanks is constructed from the average and standard deviation of the 20 most recent QCS/SRM measurements. The accuracy chart includes upper and lower warning levels ($WL=\pm 2s$) and upper and lower control levels ($CL=\pm 3s$). These values are derived from stated values of the QCS/SRM. The standard deviation (s) is specified relative to statistical confidence levels of 95% for WLs and 99% for CLs. Enter QCS/SRM results on the chart each time the sample is analyzed.
- 9.3.5 Calibration Verification, Initial and Continuing (ICV/CCV) – Immediately following calibration (ICV) and following every 18-23 samples (CCV), two calibration verifications are analyzed to assess instrument performance. The CCVs are made from the different material than the calibration standards (KNO_3), and are to be within the expected value $\pm 3s$. Failure to meet the criteria requires correcting the problem, including reanalysis of any affected samples. If not enough sample exists, the data must be qualified if reported. Specific CCV's can be found in Appendix 1.
- 9.3.6 Reduction Efficiency Verification (REV) – The REVs are made from $NaNO_2$, 50 μM NO_2 (0.70 mg N/L) and are to be within the expected value $\pm 3s$ of the equivalent, 50 μM NO_3 (0.70 mg N/L). Failure to meet the criteria requires correcting the problem.

9.4 Assessing Analyte Recovery - Percent Recovery

- 9.4.1 Analyte recovery is assessed through percent recoveries of laboratory spikes. Analyte recovery is also assessed through the

percent recovery of an organic standard that was digested with each batch of samples.

9.4.2 Percent Recovery = (Actual/Expected) x 100

9.5 Assessing Analyte Precision – Relative Percent Difference (RPD)

9.5.1 Analyte replication is assessed through duplicate analyses of samples – Relative Percent Difference.

9.5.2 $RPD = \frac{\text{Laboratory Duplicate Result 1} - \text{Laboratory Duplicate Result 2}}{(\text{Laboratory Duplicate Result 1} + \text{Laboratory Duplicate Result 2})/2} \times 100$

9.6 Corrective Actions for Out of Control Data

9.6.1 Control limit – If one measurement exceeds Accuracy Control Chart CL, repeat the analysis immediately. If the repeat measurement is within the CL, continue analyses; if it exceeds the CL, discontinue analyses and correct the problem.

9.6.2 Warning limit – If two out of three successive points exceed Accuracy Control Chart WL, analyze another sample. If the next point is within WL, continue analyses; if the next point exceeds the WL, evaluate potential bias and correct the problem.

9.6.3 Trending – If seven successive Accuracy Control Chart measurements are on the same side of the central line, discontinue analyses and correct the problem.

9.6.4 When external QCS samples are out of control, correct the problem. Reanalyze the samples analyzed between the last in-control measurement and the out-of-control one.

9.6.5 When external CCV samples are out of control, correct the problem. Reanalyze the samples analyzed between the last in-control measurement and the out-of-control one.

9.7 General Operation - To assure optimal operation and analytical results, the Reagent Blank (LRB) and CCV are tracked daily in the raw data file, copied to Reagent Blank (LRB) and CCV Control Charts.

Table 2

QC Indicator	Acceptance/ Action Limits	Action	Frequency (Batch)
Correlation Coefficient	≥ 0.998	If <0.998, evaluate data points of the calibration curve. If any data point is outside established limits, reject as outlier.	1 per batch if acceptable.

Quality Control Sample (QCS)/ Certified Reference Material (CRM)	$\pm 10\%$	If QCS value is outside $\pm 10\%$ of the target value reject the run, correct the problem and rerun samples.	Beginning of run and at end of run.
Initial Calibration Verification (ICV)	$\pm 10\%$	Recalibrate if outside acceptance limits.	Beginning of run following standard curve.
Continuing Calibration Verification (CCV)	$\pm 10\%$	If outside 10%, correct the problem. Rerun all samples following the last in-control CCV.	After every 18-23 samples.
Method Blank/Laboratory Reagent Blank (LRB)	\leq Method Quantitation Limit	If the LRB exceeds the quantitation limit, results are suspect. Rerun the LRB. If the concentration still exceeds the quantitation limit, reject or qualify the data, or raise the quantitation limit.	Following the ICV and after every 18-23 samples following the CCV.
Laboratory Fortified Sample Matrix Spike	$\pm 10\%$	If the recovery of any analyte falls outside the designated acceptance limits and the QCS is in control, the recovery problem is judged matrix induced. Repeat the LFM and if the sample results are again outside the acceptable recovery range, the sample should be reported with a "matrix induced bias" qualifier.	1/10 (spike OR duplicate)
Laboratory Duplicate	$\pm 10\%$	If the RPD fails to meet the acceptance limits, the samples should be reanalyzed. If the RPD again fails to meet the acceptance limits, the sample must be reported with a qualifier identifying the sample analysis result as not having acceptable RPD for duplicate analysis.	1/10 (spike OR duplicate)

10 CALIBRATION AND STANDARDIZATION

10.1 Calibration – Daily calibration must be performed before sample analysis may begin. Four point calibrations are used with the Technicon Bran & Luebbe AutoAnalyzer II in replicates of three. ASTM Type I digested water (reagent water) is used as the zero point in the calibration.

10.2 Working TDN Standards – See Appendix 1 for all working TDN Standards.

10.3 Prepare standard curve by plotting response on recorder of standards processed through the manifold against TDN as NO_3 –N/L concentration in standards.

Compute sample mg TDN/L concentration by comparing sample response on recorder with standard curve. The coefficient of determination (Pearson's r value) for the calibration curve as well as the calculated concentration of each calibrator is reviewed. The calculated value of each calibrator must be within ten percent of the expected value. The coefficient of determination (Pearson's r value) for the calibration curve must be greater than 0.998.

11 PROCEDURE – NEW REDUCTION COLUMN PREPARATION

11.1 Prepare Copper-Cadmium Column – Use good quality cadmium filings of 25-60 mesh size.

11.2 Clean 10 g of cadmium with 20 mL of acetone. Rinse twice with 20 mL of reagent water. Next, clean cadmium with 50 mL of 1 N Hydrochloric Acid for 1 minute. Cadmium turns silver in color. Decant Hydrochloric Acid and wash the cadmium with another 50 mL of 1 N Hydrochloric Acid for 1 minute.

11.3 Decant 1 N Hydrochloric Acid and wash the cadmium several times with reagent water.

11.4 Decant reagent water and add 20 mL of 2% (w/v) Copper Sulfate ($\text{CuSO}_4 \cdot 5\text{H}_2\text{O}$). Wash the cadmium until no blue color remains in the solution.

11.5 Decant Copper Sulfate solution and add another 20 mL of 2% (w/v) Copper Sulfate ($\text{CuSO}_4 \cdot 5\text{H}_2\text{O}$). Wash the cadmium until no blue color remains in the solution. The cadmium will be dark brown in color.

11.6 Decant Copper Sulfate solution and wash thoroughly (~10 times) with reagent water.

11.7 Set up Manifold, following general procedure of the manufacturer in the following described order.

11.8 Insert a glass wool plug at the outlet end of the column. Fill the reductor column tubing (22 cm length of 0.110-inch ID Tygon tubing) with reagent water and transfer the prepared cadmium granules to the column using a Pasteur pipette or some other method that prevents contact of cadmium granules with air. Do not allow any air bubbles to be trapped in column. Pack entire column uniformly with filings such that, visually, the packed filings have separation gaps $\leq \sim 1\text{mm}$.

- 11.9 Ammonium Chloride Reagent initiates analytical sample stream from 1.40 mL/min Yellow/Blue pump tube.
- 11.10 Air is injected from 0.32 mL/min Black/Black pump tube.
- 11.11 Sample is added from 0.16 mL/min Orange/Yellow pump tube.
- 11.12 Mixing occurs in five turn coil.
- 11.13 Air bubbles are removed from analytical sample stream using 0.60 mL/min Red/Red pump tube.
- 11.14 De-bubbled analytical sample stream passes through 22 cm reductor column.
- 11.15 Air is injected from 0.32 mL/min Black/Black pump tube.
- 11.16 Color Reagent is added from 0.32 mL/min Black/Black pump tube.
- 11.17 Mixing occurs in twenty-two turn coil.
- 11.18 Analytical sample stream enters 1.5 mm ID, 50 mm long Flow Cell pulled by 0.80 mL/min waste line. Bubbles and remainder of sample stream exit by gravity.
- 11.19 Color of analytical sample stream is quantitatively read at 550 nm by Colorimeter with 199-B021-01 Phototube, electronic output recorded on strip chart of Recorder.
- 11.20 Attach pump tubes to end rails of Proportioning Pump. Put platen on Proportioning Pump. With reagent water running through the sample line and Ammonium Chloride Reagent running through its designated line, attach the column. Make sure there are no air bubbles in the valve and attach the column to the intake side of the valve first. Open the valve to allow Ammonium Chloride Reagent Stream to flow through the column. Allow reagent water to run through the Color Reagent line.
- 11.21 Turn on Colorimeter and Recorder.
- 11.22 Check for good flow characteristics (good bubble pattern) after insertion of air bubbles beyond the column. If the column is packed too tightly, an inconsistent flow pattern will result. Allow Ammonium Chloride Reagent to flow through Column, manifold and Colorimeter for one hour.
- 11.23 At conclusion of that hour, condition the column with approximately 100 mg N/L (KNO_3) for 5 minutes, followed by approximately 100 mg N/L (NaNO_2) for 5 minutes. Turn Baseline Knob on Colorimeter to obtain 0 deflection on Recorder.
- 11.24 Attach Color Reagent line to Color Reagent. At Colorimeter Standard Calibration setting of 1.00, note deflection on Recorder. Reject Color Reagent if deflection is more than 8 out of total 100 chart units. Turn Baseline Knob on Colorimeter to obtain 0 deflection on Recorder.
- 11.25 At Colorimeter Standard Calibration setting of 1.50, analyze Secondary Nitrate Standard ($50 \mu\text{M NO}_3^-$ -N/L (0.70 mg N/L)) and Secondary Nitrite Standard ($50 \mu\text{M NO}_2^-$ -N/L (0.70 mg N/L)). If peak height of Secondary Nitrate Standard is <90% of peak height of Secondary Nitrite Standard, prepare a new cadmium reduction column.
- 11.26 Analyze Inorganic Nitrate Standards for column assessment. (See Appendix 1 and use the same standards as used for Inorganic Linearity Check.)

- 11.27 Prepare standard curve by plotting response on recorder of standards processed through the manifold against NO₃-N/L concentration in standards.
- 11.28 At the end of the run, allow reagent water to flow through the sample line for 10 minutes. Close the valve to the column, diverting flow. Allow reagent water to flow through sample, Ammonium Chloride and Color Reagent lines for one minute. Turn Proportioning Pump switch to fast pump for its allotted time.
- 11.29 Turn off Sampler, Colorimeter and Recorder. Release and remove Proportioning Pump platen. Release pump tube holders from end rails.

12 PROCEDURE – DAILY OPERATION

- 12.1 Attach pump tubes to end rails of Proportioning Pump. Put platen on Proportioning Pump. Allow reagent water to run through the sample line, Ammonium Chloride Reagent to run through its line and reagent water to run through the Color Reagent line. Check for good flow characteristics (good bubble pattern).
- 12.2 Turn on Colorimeter and Recorder. Set Colorimeter Standard Calibration setting to 1.00. Let liquid pump through the Manifold and Colorimeter for 15 minutes.
- 12.3 At the conclusion of the 15 minutes, turn Baseline Knob on Colorimeter to obtain 5 chart units deflection on Recorder.
- 12.4 Attach Color Reagent line to the Color Reagent. Open the valve to allow Ammonium Chloride Reagent Stream to flow through the column. At a Colorimeter Standard Calibration setting of 1.00, note deflection on the Recorder. Reject Color Reagent if deflection is more than 8 out of total 100 chart units. Turn Baseline Knob on the Colorimeter to obtain 0 deflection on Recorder.
- 12.5 At desired Standard Calibration (See Appendix 1), analyze inorganic linearity. Repeat the top standard to check for good replication. If replicates are not within $\pm 10\%$, repack the column and repeat. If repeating fails a second time, prepare a new cadmium reduction column. If the peak height of Secondary Nitrate Standard is <90% of the peak height of Secondary Nitrite Standard, prepare a new cadmium reduction column.
- 12.6 Analyze Working TDN Standards using the NAP Software Program. (For NAP Software Program procedures, see Appendix 2.) The NAP Software Program will prepare standard curve by plotting response on recorder of standards processed through the manifold against TDN as NO₃ –N/L concentration in standards.
- 12.7 Analyze CRM sample at the beginning of the first group of samples.
- 12.8 Analyze samples. The NAP Software Program will compute sample TDN as NO₃ –mg N/L concentration by comparing sample response on Recorder with standard curve.
- 12.9 Change the Standard Calibration if a sample peak is larger than 100%. Standard Calibration of 1.5 and 2.0 can both be turned down to 1.0. Calculate the Change in Gain by multiplying the peak height times 100/79.9 for

correcting a Standard Calibration of 1.5 to 1.0 and 100/68.0 for correcting a Standard Calibration of 2.0 to 1.0. This will give a corrected peak height. Use the corrected peak height with the daily regression in order to calculate the sample concentration in mg/L.

- 12.10 At the end of the sample run, analyze CRM sample.
- 12.11 Allow reagent water to flow through the sample line for 10 minutes. Close the valve to the column, diverting flow. Allow reagent water to flow through the sample, Ammonium Chloride and Color Reagent lines for one minute. Turn Proportioning Pump switch to fast pump for its allotted time.
- 12.12 Turn off Sampler, Colorimeter and Recorder. Release and remove Proportioning Pump platen. Release pump tubes from end rails.

13 PROCEDURE – SAMPLE DIGESTION

- 13.1 TDN/TDP samples are digested simultaneously in the same ampule. In our procedures, this ampule is a 30 mL screw cap test tube.
- 13.2 Prepare working standards, QCS (CRM), and CCV in labeled 100 mL volumetric flasks:
 - 13.2.1 Select concentration range for both TDN/TDP that best fits the sample batch from Appendix 1.
 - 13.2.2 Fill 100 mL volumetric flasks with 80 mL reagent water.
 - 13.2.3 Add appropriate amount of KNO_3 and KH_2PO_4 to each labeled working standard volumetric flask from Appendix 1.
 - 13.2.4 Add appropriate amount of glutamic/glycerophosphate to each labeled CCV and % recovery volumetric flask from Appendix 1.
 - 13.2.5 Bring up to 100 mL volume with reagent water.
 - 13.2.6 Mix each 100 mL labeled volumetric flask thoroughly
- 13.3 Sub-sample working standards into 30mL screw cap test tubes:
 - 13.3.1 Prepare 3, 30mL labeled test tubes for each working standard concentration.
 - 13.3.2 Sample rinse each test tube with the appropriate working standard.
 - 13.3.3 Add exactly 10mL of each working standard to each test tube.
 - 13.3.4 Prepare 3 labeled test tubes with exactly 10 mL reagent water for the zero point in the calibration curve.
 - 13.3.5 Set aside 3 empty labeled test tubes to be digested with the batch with digestion reagent only (labeled RB).
 - 13.3.6 Prepare 2, 30mL labeled test tubes for glutamic/glycerophosphate for percent recovery by adding exactly 10mL to each test tube.
 - 13.3.7 Prepare 2, 30mL labeled test tubes for glutamic/glycerophosphate for CCV by adding exactly 10mL of the designated CCV solution to each test tube.

- 13.3.8 Thaw a Quality Control Sample (CRM) sample stored in freezer and sub-sample exactly 10mL into a labeled 30mL test tube to be used for QCS.
- 13.4 Prepare Digestion Reagent by dissolving 20.1 g Potassium persulfate and 3 g Sodium hydroxide in a 1000 mL volumetric flask:
 - 13.4.1 Rinse volumetric flask with reagent water.
 - 13.4.2 Add 20.1 g Potassium persulfate directly to the volumetric flask.
 - 13.4.3 Add reagent water until the meniscus is slightly below full volume.
 - 13.4.4 Add 3 g Sodium Hydroxide to the persulfate and water solution, cap immediately and mix thoroughly.
 - 13.4.5 Bring to volume with reagent water.
 - 13.4.6 Make fresh daily.
 - 13.4.7 Digestion Reagent has a shelf life of about 4 hours.
- 13.5 When ready to digest, thaw frozen samples at room temperature.
- 13.6 Rinse dispensing vessel with reagent water and sample rinse with digestion reagent.
- 13.7 Add thoroughly mixed digestion reagent.
- 13.8 Check dispensing vessel for desired dispensing amount.
- 13.9 Add desired amount of digestion reagent (Typically 5mL), cap tube, shake for mixing and add test tube to pressure cooker.
- 13.10 Add desired amount of digestion reagent (5mL) to the standards at the beginning, middle and end of the sequence of loading the samples.
- 13.11 When all samples and standards have received digestion reagent and have been loaded into the pressure cooker, place pressure cooker on hot plate, add reagent water until tubes are 75% immersed, wet the gasket on the lid with a few drops of water and place lid on the pressure cooker.
- 13.12 Turn the hot plate on maximum temperature and have the pressure cooker come up to full steam. (This takes about 1 hour.)
- 13.13 When full steam is achieved, place the pressure regulator on the steam vent. Maintain heat for the cooker containing samples and standards at 3-4 psi for 55 minutes.
- 13.14 Turn off pressure cooker and unplug the hot plate when finished. Keep the lid on the pressure cooker.
- 13.15 After samples have cooled, usually the next day, remove the pressure cooker lid, add 1 mL Borate Buffer to each tube, cap, and shake.
- 13.16 Sample batch is now ready to analyze and is stable for 3 months.

14 DATA ANALYSIS AND CALCULATIONS

- 14.1 Upon completion of all analysis, results are saved to a Lotus 123 daily report file. The file is named by the run date. The daily report file for analytical batch of January 1, 2017 would be named 010117tdnp. The instrument software has calculated final sample concentration from the

designated standard curve in a program called New Analyzer Program (NAP) Software. Dilution by the analyst is noted and recalculated by multiplying the original peak height times the dilution factor to calculate a corrected peak height. Use the corrected peak height with the daily regression to calculate the sample concentration in mg/L. The analyst examines each peak height and peak marker within the NAP Software and compares it to the peak height from the chart recorder. Results are eliminated that are outside the limits of the calibration range.

15 REFERENCES

- 15.1 Technicon Industrial Method No. 158-71 W/A Tentative. 1977. Technicon Industrial Systems. Tarrytown, New York, 10591.
- 15.2 USEPA. 1979. Method No. 353.2 *in* Methods for chemical analysis of water and wastes. United States Environmental Protection Agency, Office of Research and Development. Cincinnati, Ohio. Report No. EPA-600/4-79-020 March 1979. 460pp.

Range	Pump Tubes	umoles NO3/L	mg N/L	ml 1 NO3 std/100ml	Spike Conc.	Inorganic Check For Linearity	Glutamic/Glycerphosphate for % Recovery	Nap File Created	CCV	Correction Coefficient
		0	0	DI H2O						
Low	Orn/Yel sample	25	0.35	0.5	200 umole NO3	50 NO3	1 ml Glutamic	Low TDN (group)	0.5 mL Glutamic	50 umoles
10 ml sample	Yel/Blu NH4Cl	50	0.70	1.0	12 umole PO4	50 NO2		lown2 (samp. Appendix)	0.31 mgN/L	NO3
5 ml persulfate	Std Cal. 1.5	75	1.05	1.5		35 NO3 10 NO3 3.5 NO3				
		0	0	DI H2O						
High	Orn/Grn sample	25	0.35	0.5	200 umole NO3	75 NO3	1 ml Glutamic	High TDN (group)	0.5 mL Glutamic	75 umoles
10 ml sample	Yel/Blu NH4Cl	50	0.70	1.0	12 umole PO4	50 NO3		lown2 (samp. table)	0.31 mgN/L	NO3
5 ml persulfate	Std Cal. 1.5	100	1.40	2.0		50 NO2 35 NO3 10 NO3				
		0	0	DI H2O						
XHigh	Orn/Wht sample	50	0.70	1.0	400 umole NO3	100 NO3	2 ml Glutamic	XHigh TDN (group)	1.0 mL Glutamic	100 umoles
10 ml sample	Yel/Yel NH4Cl	100	1.40	2.0	12 umole PO4	50 NO3		Xhigh TDN (samp. table)	0.72 mgN/L	NO3
5 ml persulfate	Yel/Yel DI Blk/Blk resample Std Cal 2.0	200	2.80	4.0		50 NO2 35 NO3 10 NO3				
		0	0	DI H2O						
TWS TDN	Blk/Blk sample	150	2.1	3.0	2.5 ml of	100 NO3	4 ml Glutamic	TWS TDN (group)	4 ml Glutamic	100 umoles
5 ml sample	Yel/Yel NH4Cl	300	4.2	6.0	400 umole NO3 &	50 NO3		TWS TDN (samp. table)	2.88 mgN/L	NO3
15 ml persulfate	Yel/Yel DI Blk/Blk resample Std Cal 2.0	400	5.6	8.0	12 umole PO4 Added to 2.5 ml sample prior to digestion	50 NO2 35 NO3 10 NO3				

Appendix 1. Methods and Standards Used for TDN Cadmium Reduction

UNIVERSITY OF MARYLAND CENTER FOR ENVIRONMENTAL SCIENCE
CHESAPEAKE BIOLOGICAL LABORATORY
NUTRIENT ANALYTICAL SERVICES LABORATORY
146 Williams St., Solomons MD 20688
<http://nasl.cbl.umces.edu/>

**Standard Operating Procedure for
Determination of Total Dissolved Phosphorus (TDP) and Total Phosphorus (TP) in
Fresh/Estuarine/Coastal Waters Using Alkaline Persulfate Digestion of Phosphorus
to Orthophosphate (PO₄) with Colorimetric Analysis by Random Access Discrete
Photometric Analyzer
(References Standard Methods #4500-P.B.5, #4500 P.E, and EPA Method 365.1)**

**Revision 2017-1
Replaces Revision 2015
Effective April 26, 2017**

Revised by: _____ Date: _____

Reviewed by: _____ Date: _____

Laboratory Supervisor: _____ Date: _____

Changes affecting Revision 2015

Section 1.3: Inserted If more than seven replicates are used to determine the MDL, refer to the Student's *t* test table for the appropriate n-1 value.

Section 1.7: Used references instead of conforms

Section 2.1: Added (whole water for TP)

Entire Document: Changed Table 1 to Appendix 1

Section 3.5: Deleted preparation batch definition

Section 3.12.3: Added distinct from the ICV

Section 3.23: Deleted Instrument Detection Limit

Entire Document: Changed deionized water to reagent water

Section 3.24: Changed blank matrix to matrix blank

Section 3.26: Added This is also referred to as MDL.

Section 3.27: Added This is also referred to as the Quantitation Limit

Section 3.36: Changed proscribed to prescribed

Section 3.43: Added Also referred to as CRM

Section 5.1 Changed the word should to must, Changed CBL Business Manager to the CBL Associate Director of Administration and Facilities Maintenance

Section 5.4: Updated Chemical Safety Table (Table 1)

Section 6.1: Added Windows 7 operating system

Section 7.18: Changed KH₂PO₄ standard to be made in 500 ml instead of 1L

Section 7.11: Added make fresh every 6 months

Section 7.15: Changed the Aquakem Cleaning Solution to be made with 55mL instead of 75mL

Section 8.4: Added \leq sign for freezer temp

Section 9.2.1: Changed the initial demonstration of capability acronym to IDOC

Section 9.2.2: Changed QCS checks from 10% to 3s

Section 9.2.3: Deleted from MDL description the change of operator or a new matrix is encountered, changed ambient water to natural water

Section 9.3.4: Added the words reagent blanks, deleted Set up an accuracy chart by using percent recovery since the concentration of the QCS/SRM varies

Section 9.3.5: Added ICV information to the CCV, Added See Appendix 1 for additional CCVs,

Changed TV to the expected value

Section 9.4: Changed % to read Percent

Section 9.7: Added Table 2

Section 10.1: Added the word digested

Section 10.3: Added the coefficient of determination (Pearson's *r* value) for the calibration curve as well as the calculated concentration of each calibrator is reviewed. The calculated value of each calibrator must be within ten percent of the expected value. The coefficient of determination (Pearson's *r* value) for the calibration curve must be greater than 0.998

Section 11: Added step by step descriptions for using Aquakem software

Section 12.3.5: Added labeled RB

Section 12.3.6: Changed % to percent

Section 12.13: Changed digestion time to 55 minutes

Section 14: Deleted Method Performance section

Determination of Total Dissolved Phosphorus (TDP) and Total Phosphorus (TP) in Fresh/Estuarine/Coastal Waters Using Alkaline Persulfate Digestion of Phosphorus to Orthophosphate (PO₄) with Colorimetric Analysis by Random Access Discrete Photometric Analyzer

1. SCOPE and APPLICATION

- 1.1 Potassium persulfate is used to oxidize organic and inorganic phosphorus to orthophosphate under heated acidic conditions.
- 1.2 Ammonium molybdate and potassium antimony tartrate react in an acid medium with dilute solutions of orthophosphate to form an antimony-phosphomolybdate complex which is reduced to an intensely blue-colored complex by ascorbic acid. Color is proportional to orthophosphate concentration. The method is used to analyze salinities under 34 ppt.
- 1.3 A method detection limit (MDL) of 0.0015 mg TDP as PO₄-P/L was determined using the Student's *t* value (3.14, n=7) times the standard deviation of a minimum of 7 replicates. If more than seven replicates are used to determine the MDL, refer to the Student's *t* test table for the appropriate n-1 value.
- 1.4 The Quantitation Limit for TDP as PO₄ was set at 0.0045 mg TDP as PO₄-P/L.
- 1.5 This procedure should be used by analysts experienced in the theory and application of aqueous organic and inorganic analysis. A three month training period with an analyst experienced in the analysis of TDP in aqueous samples is required.
- 1.6 This method can be used for all programs that require analysis of TDP.
- 1.7 This procedure references Standard Methods #4500-P.B.5, #4500 P.E, and EPA Method 365.1 (1979).

2. SUMMARY

- 2.1 An exact amount of filtered samples (whole water for TP) are placed in test tubes where an exact amount of Potassium Persulfate Digestion Reagent is added. Under initially alkaline conditions and heat, nitrate is the sole nitrogen product. As the potassium persulfate continues to oxidize, conditions become acidic and orthophosphate becomes the sole phosphorus product.
- 2.2 The now digested samples are buffered, then mixed with a sulfuric acid-antimony-molybdate solution, and subsequently with an ascorbic acid solution, yielding an intense blue color suitable for photometric measurement.

3. DEFINITIONS

- 3.1 Acceptance Criteria – Specified limits placed on characteristics of an item, process, or service defined in a requirement document. (ASQC)

- 3.2 Accuracy – The degree of agreement between an observed value and an accepted reference value. Accuracy includes a combination of random error (precision) and systematic error (bias) components which are due to sampling and analytical operations; a data quality indicator. (QAMS)
- 3.3 Aliquot – A discrete, measured, representative portion of a sample taken for analysis. (EPA QAD Glossary)
- 3.4 Analytical Range – There are multiple analytical ranges/standard curves used for determination of TDP. See Appendix 1 for all analytical ranges used.
- 3.5 Batch – Environmental samples, which are prepared and /or analyzed together with the same process and personnel, using the same lot(s) of reagents. An **analytical batch** is composed of prepared environmental samples (extracts, digestates, or concentrates) and/or those samples not requiring preparation, which are analyzed together as a group using the same calibration curve or factor. An analytical batch can include samples originating from various environmental matrices and can exceed 20 samples. (NELAC/EPA)
- 3.6 Blank- A sample that has not been exposed to the analyzed sample stream in order to monitor contamination during sampling, transport, storage or analysis. The blank is subjected to the usual analytical and measurement process to establish a zero baseline or background value and is sometimes used to adjust or correct routine analytical results. (ASQC)
- 3.7 Calibrate- To determine, by measurement or comparison with a standard, the correct value of each scale reading on a meter or other device, or the correct value for each setting of a control knob. The levels of the applied calibration standard should bracket the range of planned or expected sample measurements. (NELAC)
- 3.8 Calibration – The set of operations which establish, under specified conditions, the relationship between values indicated by a measuring device. The levels of the applied calibration standard should bracket the range of planned or expected sample measurements. (NELAC)
- 3.9 Calibration Blank – A volume of reagent water fortified with the same matrix as the calibration standards, without the analyte added.
- 3.10 Calibration Curve – The graphical relationship between known values, such as concentrations, or a series of calibration standards and their analytical response. (NELAC)
- 3.11 Calibration Method – A defined technical procedure for performing a calibration. (NELAC)
- 3.12 Calibration Standard – A substance or reference material used to calibrate an instrument. (QAMS)
- 3.12.1 Initial Calibration Standard (STD) – A series of standard solutions used to initially establish instrument calibration responses and develop calibration curves for individual target analytes.

- 3.12.2 Initial Calibration Verification (ICV) – An individual standard, analyzed initially, prior to any sample analysis, which verifies acceptability of the calibration curve or previously established calibration curve.
- 3.12.3 Continuing Calibration Verification (CCV) – An individual standard, distinct from the ICV, which is analyzed after every 18-23 field sample analysis.
- 3.13 Certified Reference Material (CRM) – A reference material one or more of whose property values are certified by a technically valid procedure, accompanied by or traceable to a certificate or other documentation which is issued by a certifying body. (ISO 17025)
- 3.14 Corrective Action – Action taken to eliminate the causes of an existing nonconformity, defect or other undesirable situation in order to prevent recurrence. (ISO 8402)
- 3.15 Deficiency – An unauthorized deviation from acceptable procedures or practices. (ASQC)
- 3.16 Demonstration of Capability – A procedure to establish the ability of the analyst to generate acceptable accuracy. (NELAC)
- 3.17 Detection Limit – The lowest concentration or amount of the target analyte that can be determined to be different from zero by a single measurement at a stated degree of confidence.
- 3.18 Duplicate Analysis – The analyses of measurements of the variable of interest performed identically on two sub samples (aliquots) of the same sample. The results from duplicate analyses are used to evaluate analytical or measurement precision but not the precision of sampling, preservation or storage internal to the laboratory. (EPA-QAD)
- 3.19 External Standard (ES) – A pure analyte (potassium phosphate (KH_2PO_4)) that is measured in an experiment separate from the experiment used to measure the analyte(s) in the sample. The signal observed for a known quantity of the pure external standard is used to calibrate the instrument response for the corresponding analyte(s). The instrument response is used to calculate the concentrations of the analyte(s) in the unknown sample.
- 3.20 Field Duplicates (FD1 and FD2) – Two separate samples collected at the same time and place under identical circumstances and treated exactly the same throughout field and laboratory procedures. Analyses of FD1 and FD2 provide a measure of the precision associated with sample collection, preservation and storage, as well as with laboratory procedures.
- 3.21 Field Reagent Blank (FRB) – An aliquot of reagent water or other blank matrix that is placed in a sample container in the laboratory and treated as a sample in all respects, including shipment to the sampling site, exposure to the sampling site conditions, storage, preservation, and all analytical procedures. The purpose of the FRB is to determine if method analytes or other interferences are present in the field environment.

- 3.22 Holding time – The maximum time that samples may be held prior to analysis and still be considered valid. (40 CFR Part 136) The time elapsed from the time of sampling to the time of extraction or analysis, as appropriate.
- 3.23 Laboratory Duplicates (LD1 and LD2) – Two aliquots of the same sample taken in the laboratory and analyzed separately with identical procedures. Analyses of LD1 and LD2 indicate precision associated with laboratory procedures, but not with sample collection, preservation, or storage procedures.
- 3.24 Laboratory Reagent Blank (LRB) – A matrix blank (i.e., reagent water) that is treated exactly as a sample including exposure to all glassware, equipment, solvents, and reagents that are used with other samples. The LRB is used to determine if method analytes or other interferences are present in the laboratory environment, the reagents, or the instrument.
- 3.25 Laboratory Control Sample (LCS) – A sample matrix, free from the analytes of interest, spiked with verified known amounts of analytes from a source independent of the calibration standard or a material containing known and verified amounts of analytes. The LCS is generally used to establish intra-laboratory or analyst-specific precision and bias or to assess the performance of all or a portion of the measurement system. (NELAC)
- 3.26 Limit of Detection (LOD) – The lowest concentration level that can be determined by a single analysis and with a defined level of confidence to be statistically different from a blank. . This is also referred to as MDL. (ACS)
- 3.27 Limit of Quantitation (LOQ) – The minimum levels, concentrations, or quantities of a target variable (target analyte) that can be reported with a specified degree of confidence. The LOQ is set at 3 to 10 times the LOD, depending on the degree of confidence desired. This is also referred to as the Quantitation Limit.
- 3.28 Linear Dynamic Range (LDR) – The absolute quantity over which the instrument response to an analyte is linear. This specification is also referred to as the Linear Calibration Range (LCR).
- 3.29 Material Safety Data Sheets (MSDS) – Written information provided by vendors concerning a chemical’s toxicity, health hazards, physical properties, fire, and reactivity data including storage, spill, and handling precautions.
- 3.30 May – Denotes permitted action, but not required action. (NELAC)
- 3.31 Method Detection Limit (MDL) – The minimum concentration of an analyte that can be identified, measured, and reported with 99% confidence that the analyte concentration is greater than zero. (Standard Methods)
- 3.32 Must – Denotes a requirement that must be met. (Random House College Dictionary)

- 3.33 Photometer – Measures the absorbance of the solution in the cell in a multicell cuvette. Light passes from the lamp through the condensing lenses to the interference filter. The plane surface of the first condensing lens is coated with a material which reflects heat and infrared light. The filters are mounted on a filter wheel. There are 15 positions for filters. Each filter corresponds to a wavelength of interest. The 880 nm filter is specified by the test definition for orthophosphate. After passing through the filter the light is converted into a stream of light pulses by a chopper. Then the light is directed via a quartz fiber through a focusing lens and a slit to the beam divider. The beam divider divides the light into two parts. A specified portion is reflected to the reference detector, which monitors the light level fluctuations. The remaining major portion of the light beam goes through the liquid in the cell to the signal detector, which measures the amount of light absorbed.
- 3.34 Precision – The degree to which a set of observations or measurements of the same property, obtained under similar conditions, conform to themselves; a data quality indicator. Precision is usually expressed as standard deviation, variance or range, in either absolute or relative terms. (NELAC)
- 3.35 Preservation – Refrigeration, freezing, and/or reagents added at the time of sample collection (or later) to maintain the chemical and or biological integrity of the sample.
- 3.36 Quality Control Sample (QCS) – A sample of analyte of known and certified concentration. The QCS is obtained from a source external to the laboratory and different from the source of calibration standards. It is used to check laboratory performance with externally prepared test materials. Also referred to as CRM.
- 3.37 Run Cycle – Typically a day of operation – the entire analytical sequence from sampling the first standard to the last sample of the day.
- 3.38 Sample Segment – Bar-coded metal tray that holds up to fourteen four milliliter auto analyzer vials containing samples or standards. The user identifies each vial in the operating software.
- 3.39 Sample Segment Holder – An automated temperature controlled carousel that contains up to six sample segments. This carousel spins in clockwise or counterclockwise manner to move the sample segments into position for analysis. This carousel format allows for continuous processing.
- 3.40 Sensitivity – The capability of a test method or instrument to discriminate between measurement responses representing different levels (concentrations) of a variable of interest.
- 3.41 Shall – Denotes a requirement that is mandatory whenever the criterion for conformance with the specification requires that there be no deviation. (ANSI)
- 3.42 Should – Denotes a guideline or recommendation whenever noncompliance with the specification is permissible. (ANSI)

- 3.43 Standard Reference Material (SRM) – Material which has been certified for specific analytes by a variety of analytical techniques and/or by numerous laboratories using similar analytical techniques. These may consist of pure chemicals, buffers, or compositional standards. The materials are used as an indication of the accuracy of a specific analytical technique. Also referred to as CRM.
- 3.44 Test Definition – A photometric test consisting of a user defined testing sequence, reagent additions, calibration standards, incubations and absorption results.
- 3.45 Test Flow – Functions to define the parameter for reagent and sample dispensing, dilution, incubation and measurement.

















4 INTERFERENCES

- 4.1 Suspended matter in the sample will scatter light as it passes through the cuvette to the detector. High blank responses will result. The identified sample will be reanalyzed.
- 4.2 Blemishes in the cuvette, as result of the manufacturing process, will result in high blank responses. The identified sample will be reanalyzed.
- 4.3 High silica concentrations cause positive interferences. Silicon at a concentration of 100 μ M Si causes interferences equivalent to approximately 0.04 μ M P.

5 SAFETY

- 5.1 Safety precautions must be taken when handling reagents, samples and equipment in the laboratory. Protective clothing including lab coats, safety glasses and enclosed shoes must be worn. In certain situations, it will be necessary to also use gloves and/or a face shield. If solutions come in contact with eyes, flush with water continuously for 15 minutes. If solutions come in contact with skin, wash thoroughly with soap and water. Contact Solomons Rescue Squad (911) if emergency treatment is needed and also inform the CBL Associate Director of Administration and Facilities Maintenance of the incident. Contact the CBL Associate Director of Administration and Facilities Maintenance if additional treatment is required.
- 5.2 The toxicity or carcinogenicity of each reagent used in this procedure may not have been fully established. Each chemical should be regarded as a potential health hazard and exposure should be as low as reasonably achievable. Cautions are included for known hazardous materials and procedures.
- 5.3 Do not wear jewelry when troubleshooting electrical components. Even low voltage points are dangerous and can injure if allowed to short circuit.
- 5.4 The following hazard classifications are listed for the chemicals used in this procedure. Detailed information is provided on Material Safety Data Sheets (MSDS).

Table 1

Chemical	Health Hazard	Fire Hazard	Instability Hazard	Specific Hazard	
Sodium Hydroxide	3	0	1	ALK, COR	 
Sulfuric Acid	4	0	2	ACID, COR	
Ammonium molybdate	4	0	1	Irritant	 
Ascorbic Acid	1	0	0	ACID	
Potassium antimonyl tartrate hemihydrate	2	0	0		
Potassium dihydrogen phosphate	2	0	0		
Chloroform	3	0	0		 
Hydrochloric Acid	3	0	2	ACID, COR	 
Clorox	3	0	0		
Potassium Persulfate	2	0	2	OXY	  
Boric Acid	2	0	0		 

On a scale of 0 to 4 the substance is rated on four hazard categories: health, flammability, reactivity, and contact. (0 is non-hazardous and 4 is extremely hazardous)

HAZARD RATING

Health Hazard - Blue: 4 – deadly, 3 – extreme danger, 2 – hazardous, 1 – slightly hazardous, 0 – normal material

Fire Hazard - Red: Flash Points: 4 – below 73° F, 3 – below 100° F, 2 – below 200° F, 1 – above 200° F, 0 – will not burn

Instability Hazard - Yellow: 4 – may detonate, 3 – Shock and heat may detonate, 2 – violent chemical change, 1 – unstable is heated, 0 - stable

Specific Hazard - White: Acid = ACID, Alkali = ALK, Corrosive = COR, Oxidizer = OXY

6 EQUIPMENT AND SUPPLIES

- 6.1 Aquakem 250 multi-wavelength automated discrete photometric analyzer. Aquakem 250 control software operates on a computer running Microsoft Windows NT, XP or 7 operating system.
- 6.2 Freezer, capable of maintaining $-20 \pm 5^{\circ}$ C.
- 6.3 Lab ware – All reusable lab ware (glass, Teflon, plastic, etc) should be sufficiently clean for the task objectives. This laboratory cleans all lab ware related to this method with a 10% HCl (v/v) acid rinse. This laboratory cleans all lab ware that has held solutions containing ammonium molybdate with 10% NaOH (w/v) rinse.
- 6.4 Pressure Cooker with pressure regulator and pressure gauge.
- 6.5 Hot plate with variable heat settings.

7 REAGENTS AND STANDARDS

- 7.1 Purity of Water – Unless otherwise indicated, references to water shall be understood to mean reagent water conforming to Specification D 1193, Type I. Freshly prepared water should be used for making the standards intended for calibration. The detection limits of this method will be limited by the purity of the water and reagents used to make the standards.
- 7.2 Purity of Reagents – Reagent grade chemicals shall be used in all tests. Unless otherwise indicated, it is intended that all reagents shall conform to specifications of the Committee on Analytical Reagents of the American Chemical Society, where such specifications are available. Other grades may be used, provided it is first ascertained that the reagent is of sufficiently high purity to permit its use without compromising the accuracy of the determination.

7.3 9.8 N Sulfuric Acid

Sulfuric Acid (concentrated H ₂ SO ₄)	54.4 mL
Reagent water	up to 200 mL

In a 200 mL volumetric flask, add approximately 120 mL reagent water. Add 54.4 mL H₂SO₄ to the reagent water, let cool, and bring to volume. Write the name of preparer, preparation date, reagent manufacturer, manufacturer lot number in the Analytical Reagent log book. The reagent is stable for one year.

7.4 Ammonium molybdate solution

Ammonium molybdate	8 g
Reagent water	up to 100 mL

In a 100 mL plastic volumetric flask, dissolve, with immediate inversion, 8 g of ammonium molybdate, in approximately 90 mL reagent water. Bring flask to volume. Store flask in dark at room temperature. Write the name of preparer, preparation date, reagent manufacturer, manufacturer lot

number in the Analytical Reagent log book. The reagent is stable for one month. Discard if white precipitate appears in flask or on threads of cap.

7.5 Potassium antimonyl tartrate solution

Potassium antimonyl tartrate	0.6 g
------------------------------	-------

In a 100 mL plastic volumetric flask dissolve 0.6g potassium antimonyl tartrate hemihydrate, in approximately 90 mL reagent water. Bring flask up to volume. Store flask at room temperature. Write the name of preparer, preparation date, reagent manufacturer, manufacturer lot number in the Analytical Reagent log book. Reagent is stable for one year.

7.6 Ascorbic acid solution

Ascorbic Acid	3.6 g
---------------	-------

In a 100 mL plastic volumetric flask dissolve 3.6 g ascorbic acid in approximately 90 mL reagent water. Bring flask up to volume. Store flask in refrigerator. Write the name of preparer, preparation date, reagent manufacturer, manufacturer lot number in the Analytical Reagent log book. Reagent is stable for two months.

7.7 Triple Reagent

9.8 N Sulfuric Acid	38.2 mL
---------------------	---------

Reagent Water	1.8 mL
---------------	--------

Ammonium molybdate solution	12 mL
-----------------------------	-------

Potassium antimonyl tartrate solution	4.0 mL
---------------------------------------	--------

Add 38.2 mL 9.8N sulfuric Acid and 1.8 mL reagent water to a 60 mL reagent container. Carefully add 12 mL ammonium molybdate solution to the reagent container. Carefully add 4.0 mL potassium antimonyl tartrate solution to the reagent container. Cap. Invert 6 times to mix. Write the name of preparer, preparation date, reagent manufacturer, manufacturer lot number in the Analytical Reagent log book. Reagent is stable for two weeks.

7.8 Orthophosphate Stock Standard, 12,000 μ M –

Potassium dihydrogen phosphate (KH_2PO_4), primary standard grade, dried at 45 C	0.816 g
--	---------

Reagent water	up to 500 mL
---------------	--------------

In a 500 mL volumetric flask, dissolve 0.816 g of potassium dihydrogen phosphate in approximately 400 mL reagent water. Bring flask to volume with reagent water (1mL contains 12 μ moles P). Add 1 mL chloroform as a preservative. Write the name of preparer, preparation date, reagent manufacturer, manufacturer lot number in the Analytical Reagent log book. Make fresh every 6 months.

7.9 Secondary Orthophosphate Standard –

Stock Orthophosphate Standard	1.0 mL
-------------------------------	--------

Reagent water	up to 100 mL
---------------	--------------

In a 100 mL volumetric flask, dilute 1.0 mL of stock orthophosphate standard to 100 mL with reagent water to yield a concentration of 120 μM $\text{PO}_4\text{-P/L}$ (1 mL contains 1.2 $\mu\text{moles P}$). Write the name of preparer, preparation date, reagent manufacturer, manufacturer lot number in the Analytical Standard log book. Make fresh every 4 weeks.

7.10 Working Orthophosphate Standards for TDP – See Appendix 1 for all working orthophosphate standards for TDP. Working orthophosphate standards for TDP are made with Secondary Orthophosphate Standard. Write the name of preparer, preparation date, reagent manufacturer, manufacturer lot number in the Analytical Standard log book. Make fresh for every digestion batch.

7.11 Glycerophosphate Stock Standard –

B-Glycerophosphoric acid, disodium salt, 5 hydrate	0.0473 g
Reagent water	up to 500 mL
Chloroform (CHCl_3)	0.5 mL

In a 500 mL volumetric flask, dissolve 0.0473 g of glycerophosphoric acid in about 400 mL of reagent water and dilute to 500 mL with reagent water. Add 0.5 mL of chloroform as a preservative. Write the name of preparer, preparation date, reagent manufacturer, manufacturer lot number in the Analytical Standard log book. Make fresh every 6 months.

7.12 Working Glycerophosphate Standard for TDP – See Appendix 1 for all working glycerophosphate standards for TDP.

Write the name of preparer, preparation date, reagent manufacturer, manufacturer lot number in the Analytical Standard log book. Make fresh for every digestion batch.

7.13 Potassium Persulfate Digestion Reagent –

Sodium Hydroxide (NaOH)	3 g
Potassium Persulfate ($\text{K}_2\text{S}_2\text{O}_8$), Low N	20.1 g
Reagent water	up to 1000 mL

In a 1000 mL volumetric flask, dissolve 3g of sodium hydroxide and 20.1 g of potassium persulfate in ~800mL of reagent water. Dilute to 1000 mL with reagent water. Write the name of preparer, preparation date, reagent manufacturer, manufacturer lot number in the Analytical Reagent log book. Make fresh daily. See Appendix 1 for potassium persulfate digestion reagent used with Targeted Watershed Samples (TWS).

7.14 Borate Buffer Solution –

Boric Acid (H_3BO_3)	61.8 g
--	--------

Sodium Hydroxide (NaOH)	8 g
Reagent water	up to 1000 mL

In a 1000 mL volumetric flask, dissolve 61.8 g of boric acid in ~ 300mL reagent water. Add 8g of sodium hydroxide and dilute to 1000mL with reagent water. Write the name of preparer, preparation date, reagent manufacturer, manufacturer lot number in the Analytical Reagent log book. Make fresh every 4 months.

7.15 Aquakem Cleaning Solution –

Clorox	55.0 mL
--------	---------

In a 100 mL volumetric flask, dilute 55.0 mL of Clorox to volume with 45mL reagent water to yield a concentration of 75% Clorox. Write name of preparer, preparation date, reagent manufacturer, manufacturer lot number in the Analytical Reagent log book. Reagent is stable for six months.

8 SAMPLE COLLECTION, PRESERVATION, AND STORAGE

8.1 Water collected for TDP should be filtered through a Whatman GF/F glass fiber filter (nominal pore size 0.7 μm), or equivalent.

8.2 Prior to initial use, capped 30 mL test tubes must be digested with Digestion Reagent, then rinsed thoroughly with reagent water following laboratory glassware cleaning methods.

8.3 A prescribed amount (typically 10mL) of sample should be added to each sample rinsed, capped 30mL test tube.

8.4 Water collected for TDP should be frozen at $\leq -20^\circ \text{C}$.

8.5 Frozen TDP samples may be stored longer than 28 days. It has been shown that frozen QCS samples up to a year old still fall well within the control limits.

8.6 Digested TDP samples may be stored up to three months.

8.7 TDP samples may be refrigerated at 4°C for no longer than one day.

9 QUALITY CONTROL

9.1 The laboratory is required to operate a formal quality control (QC) program.

The minimum requirements of this program consist of an initial demonstration of laboratory capability and the continued analysis of laboratory instrument blanks and calibration standard material, analyzed as samples, as a continuing check on performance. The laboratory is required to maintain performance records that define the quality of data generated.

9.2 Initial Demonstration of Capability

9.2.1 The initial demonstration of capability (iDOC) – is used to characterize instrument performance (MDLs) and laboratory

performance (analysis of QC samples) prior to the analyses conducted by this procedure.

- 9.2.2 Quality Control Sample (QCS/SRM) – When using this procedure, a quality control sample is required to be analyzed during the run, to verify data quality and acceptable instrument performance. If the determined concentrations are not within $\pm 3s$ of the certified values, performance of the determinative step of the method is unacceptable. The source of the problem must be identified and corrected before either proceeding with the initial determination of MDLs or continuing with analyses.
- 9.2.3 Method Detection Limits (MDLs) – MDLs should be established for TDP using a low level natural water sample, typically three to five times higher than the estimated MDL. To determine the MDL values, analyze seven replicate aliquots of water. Perform all calculations defined in the procedure (Section 13) and report the concentration values in the appropriate units. Calculate the MDL as follows:

$$\text{MDL} = S t_{(n-1, 1-\alpha=0.99)}$$

Where,

S = Standard deviation of the replicate analyses.

n=number of replicates

$t_{(n-1, 1-\alpha=0.99)}$ = Student's *t* value for the 99% confidence level with n-1 degrees of freedom ($t=3.14$ for 7 replicates.)

- 9.2.4 MDLs should be determined annually, whenever there is a significant change in instrumental response or a significant change in instrument configuration

9.3 Assessing Laboratory Performance

- 9.3.1 Laboratory Reagent Blank (LRB) – The laboratory must analyze at least one LRB with each batch of samples. The LRB consists of reagent water treated the same as the samples. An amount of analyte above the MDL (TDP) found in LRB indicates possible reagent or laboratory environment contamination. LRB data are used to assess and correct contamination from the laboratory environment.
- 9.3.2 Quality Control Sample (QCS)/ Standard Reference Material (SRM) – When using this procedure, a quality control sample is required to be analyzed at the beginning of the run and end of the run, to verify data quality and acceptable instrument performance. If the determined concentrations are not within $\pm 3s$ of the certified values, performance of the determinative step of the method is unacceptable. The source of the problem must be identified and corrected before either proceeding with the initial determination of MDLs or

continuing with the analyses. The results of these QCS/SRM samples shall be used to determine sample batch acceptance.

- 9.3.3 The QCS are obtained from a source external to the laboratory and different from the source of calibration standards.
- 9.3.4 Control Charts – The Accuracy Control Chart for QCS/SRM samples and digested reagent blanks is constructed from the average and standard deviation of the 20 most recent QCS/SRM measurements. The accuracy chart includes upper and lower warning levels ($WL=\pm 2s$) and upper and lower control levels ($CL=\pm 3s$). These values are derived from stated values of the QCS/SRM. The standard deviation (s) is specified relative to statistical confidence levels of 95% for WLs and 99% for CLs. Enter QCS/SRM results on the chart each time the sample is analyzed
- 9.3.5 Calibration Verification, Initial and Continuing (ICV/CCV) – Immediately following calibration (ICV) and following every 18-23 samples, two calibration verifications are analyzed to assess instrument performance. The CCVs are made from the different material than the calibration standards (KH_2PO_4), and are to be within the expected value $\pm 3s$. Failure to meet the criteria requires correcting the problem, including reanalysis of any affected samples. If not enough sample exists, the data must be qualified if reported. Specific CCV's can be found in Appendix 1.

9.4 Assessing Analyte Recovery - Percent Recovery

- 9.4.1 Analyte recovery is assessed through percent recoveries of laboratory spikes. Analyte recovery is also assessed through the percent recovery of an organic standard that was digested with each batch of samples.
- 9.4.2 Percent Recovery = (Actual/Expected) x 100

9.5 Assessing Analyte Precision – Relative Percent Difference (RPD)

- 9.5.1 Analyte replication is assessed through duplicate analyses of samples – Relative Percent Difference.
- 9.5.2 $RPD = (\text{Laboratory Duplicate Result 1} - \text{Laboratory Duplicate Result 2}) / [(\text{Laboratory Duplicate Result 1} + \text{Laboratory Duplicate Result 2}) / 2] \times 100$

9.6 Corrective Actions for Out of Control Data

- 9.6.1 Control limit – If one measurement exceeds Accuracy Control Chart CL, repeat the analysis immediately. If the repeat measurement is within the CL, continue analyses; if it exceeds the CL, discontinue analyses and correct the problem.
- 9.6.2 Warning limit – If two out of three successive points exceed Accuracy Control Chart WL, analyze another sample. If the next

- point is within WL, continue analyses; if the next point exceeds the WL, evaluate potential bias and correct the problem.
- 9.6.3 Trending – If seven successive Accuracy Control Chart measurements are on the same side of the central line, discontinue analyses and correct the problem.
 - 9.6.4 When external QCS samples are out of control, correct the problem. Reanalyze the samples analyzed between the last in-control measurement and the out-of-control one.
 - 9.6.5 When external CCV samples are out of control, correct the problem. Reanalyze the samples analyzed between the last in-control measurement and the out-of-control one.

9.7 General Operation - To assure optimal operation and analytical results, the Reagent Blank (LRB) and CCV are tracked daily in the raw data file, copied to Reagent Blank (LRB) and CCV Control Charts.

Table 2

QC Indicator	Acceptance/ Action Limits	Action	Frequency (Batch)
Correlation Coefficient	≥ 0.998	If <0.998, evaluate data points of the calibration curve. If any data point is outside established limits, reject as outlier.	1 per batch if acceptable.
Quality Control Sample (QCS)/ Certified Reference Material (CRM)	± 10%	If QCS value is outside ± 10% of the target value reject the run, correct the problem and rerun samples.	Beginning of run and at end of run.
Initial Calibration Verification (ICV)	± 10%	Recalibrate if outside acceptance limits.	Beginning of run following standard curve.
Continuing Calibration Verification (CCV)	± 10%	If outside 10%, correct the problem. Rerun all samples following the last in-control CCV.	After every 18-23 samples.
Method Blank/Laboratory Reagent Blank (LRB)	≤ Method Quantitation Limit	If the LRB exceeds the quantitation limit, results are suspect. Rerun the LRB. If the concentration still exceeds the quantitation limit, reject or qualify the data, or raise the quantitation limit.	Following the ICV and after every 18-23 samples following the CCV.

Laboratory Fortified Sample Matrix Spike	± 10%	If the recovery of any analyte falls outside the designated acceptance limits and the QCS is in control, the recovery problem is judged matrix induced. Repeat the LFM and if the sample results are again outside the acceptable recovery range, the sample should be reported with a “matrix induced bias” qualifier.	1/10 (spike OR duplicate)
Laboratory Duplicate	± 10%	If the RPD fails to meet the acceptance limits, the samples should be reanalyzed. If the RPD again fails to meet the acceptance limits, the sample must be reported with a qualifier identifying the sample analysis result as not having acceptable RPD for duplicate analysis.	1/10 (spike OR duplicate)

10 CALIBRATION AND STANDARDIZATION

10.1 Calibration – Daily calibration must be performed before sample analysis may begin. See Table 1 for the calibrators used for TDP analysis. All calibrators are made in replicates of two. ASTM Type I digested water is used as the zero point in the calibration.

10.2 Working TDP Standards –Appendix 1 defines all working TDP Standards.

10.3 The instrument software prepares a standard curve for each set of calibrators. A graph plotting measured absorbance against standard concentration is presented for review and approval. If acceptance criteria are not met the entire curve can be reanalyzed or individual standards can be reanalyzed. One standard value (original or reanalyzed) for each and every standard is incorporated in the curve. The coefficient of determination (Pearson’s r value) for the calibration curve as well as the calculated concentration of each calibrator is reviewed. The calculated value of each calibrator must be within ten percent of the expected value. The coefficient of determination (Pearson’s r value) for the calibration curve must be greater than 0.998.

11 PROCEDURE – DAILY OPERATIONS QUALITY CONTROL

- 11.1 Turn on computer. Computer will automatically initiate Konelab software. Once software is running, turn on instrument and allow connection between instrument and computer to complete.
- 11.2 Discard any water remaining in the water reservoir from the previous analytical run. Fill the water reservoir with fresh reagent water.
- 11.3 Organize and label cups for samples to be analyzed. Begin daily bench sheet documentation.
- 11.4 Once water reservoir is full, use instrument software to click More, Instrument Actions, and Perform Water Wash. Complete at least five perform water wash cycles.
- 11.5 After performing water washes, clean the dispensing needle by performing test washes. Click More, Instrument Actions, More, Adjustment Program. Once in the Adjustment Program click, 4-Dispensing Unit, 1-Dispenser, 8-Test Wash. Perform 8 to 10 Test Washing. When complete, press “Q” to quit until you are able to bring up the Main Page.
- 11.6 Perform Start Up operations by clicking Start Up at the bottom of the Main Page.
- 11.7 Gather reagents from refrigerator during startup. Assess standards and reagents. Prepare any reagent that has exceeded the time over which it is considered stable.
- 11.8 Once startup is complete, check the instrument water blanks by clicking More, Instrument Actions, More, Check Water Blank.. If any of the instrument blanks are outside their predefined and software controlled limits, the user will be notified on the main menu page. User takes corrective action to return instrument functions to controlled limits.
- 11.9 Load reagents in specified position in reagent carousel and place in refrigerated reagent compartment. Reagent positions can be found by clicking reagents at the top of the main page.
- 11.10 Load working standards in a sample segment, identify the standards in their positions from the drop down menus at the individual segment positions, and load into instrument. (Click Samples from the top of the Main Page, then click desired segment number.)
- 11.11 Select the method to be calibrated by clicking Calibr./QC Selection on the bottom of the main page.. See Appendix 1 for the method to be calibrated. Click Calibrate at the bottom of the page. The three methods will now show as pending. Return to the main page.
- 11.12 Start instrument and calibration by clicking Page Up on the keyboard. This may also be a green button on the keyboard – See test flow below for stepwise instrument functions for the analysis of standards and samples.
Test Flow – Method of Analysis, Stepwise
 - 165 µL sample to cuvette with mixing
 - Blank response measurement at 880 nm
 - 14 µL Triple Reagent to cuvette with mixing

- 7 μL Ascorbic Acid Reagent to cuvette with mixing
 - Incubation, 600 seconds, 37°C
 - End point absorbance measurement, 880 nm
 - Software processes absorbance value, blank response value and uses calibration curve to calculate analyte concentration (mg/L P as PO_4)
 - User is notified if any measured values used to calculate final concentration are outside preset limits. If so, analyst has options to accept result, rerun the sample or rerun the sample diluted to a user or software specified factor.
 - User is notified of each blank response value. Blank response >0.001 absorbance units indicates a scratched cuvette or turbid sample. If the blank response value exceeds 0.001 absorbance units, the analyst specifies that the sample is reanalyzed. If the blank response value of the reanalyzed sample is <0.001 absorbance units, the reanalyzed result is accepted. If the same concentration and blank response value >0.001 absorbance units is again obtained, the results are accepted.
- 11.13 Organize samples, reagent blanks, check standards and all quality control samples while instrument performs calibrations.
- 11.14 As calibration curves are produced by the instrument, review them for acceptability. The instrument software prepares a standard curve for each set of calibrators. A graph plotting measured absorbance against standard concentration is presented for review and approval. If acceptance criteria are not met, either the entire curve shall be reanalyzed or individual standards shall be reanalyzed, depending on the violation. One standard value (original or reanalyzed) for each and every calibrator is incorporated in the curve.
- 11.15 Once calibration curves are accepted, samples are loaded into the sample segments and loaded into the instrument for analysis. After the Reagent Blank, the first sample analyzed should be an ICV (initial calibration verification) sample. There should be one ICV sample for each calibration curve, of a concentration close to the middle of each range.
- 11.16 Samples are loaded into the segments and analyzed. CCV (Continuing Calibration Verification) samples follow every 18-23 samples. Standard Reference Material (SRM) samples, as well as Laboratory Reagent Blanks (LRB) are scattered throughout the analytical batch. Throughout the analytical batch, samples are chosen as laboratory duplicates and laboratory spikes to assess analyte precision and analyte recovery, respectively. The total number of duplicates and spikes performed will be equal to or greater than ten percent of the total number of samples in the analytical batch.
- 11.17 As sample analysis is complete, results must be reviewed and accepted manually. If results fall outside acceptance limits, the sample should be reanalyzed. If sample result exceeds the highest standard of the highest calibration range, the samples can be automatically diluted by the instrument and reanalyzed.
- 11.18 Upon completion of all analysis, results are saved to a daily report file. Click Report on the bottom of the main page, More, Results To File, and select one row per result. The file is then named by the run date. The daily

- report file for analytical batch of January 3, 2017 would be named 010317.
The file is converted to Microsoft Excel for data work up.
- 11.19 All reagents are removed from the reagent chamber and returned to the refrigerator. Reagents that have exceeded their stability period are discarded.
 - 11.20 Click on Stand By on the bottom of the main page and insert Aquakem Cleaning Solution into the instrument. This initiates shut down procedures. Daily files are cleared from the instrument software by clicking More, Management, Clear Daily Files. The software is exited and the instrument is turned off. The computer is turned off.
 - 11.21 The waste is flushed down the drain with copious amounts of tap water. The waste cuvette box is moved to the fume hood and covered.

12 PROCEDURE – SAMPLE DIGESTION

- 12.1 TDN/TDP samples are digested simultaneously in the same ampule. In our procedures, this ampule is a 30 mL screw cap test tube.
- 12.2 Prepare working standards, QCS (CRM), and CCV in labeled 100 mL volumetric flasks:
 - 12.2.1 Select concentration range for both TDN/TDP that best fits the sample batch from Appendix 1.
 - 12.2.2 Fill 100 mL volumetric flasks with 80 mL reagent water.
 - 12.2.3 Add appropriate amount of KNO_3 and KH_2PO_4 to each labeled working standard volumetric flask from Appendix 1.
 - 12.2.4 Add appropriate amount of glutamic/glycerophosphate to each labeled CCV and percent recovery volumetric flask from Appendix 1.
 - 12.2.5 Bring up to 100 mL volume with reagent water.
 - 12.2.6 Mix each 100 mL labeled volumetric flask thoroughly
- 12.3 Sub-sample working standards into 30mL screw cap test tubes:
 - 12.3.1 Prepare 2, 30mL labeled test tubes for each working standard concentration.
 - 12.3.2 Sample rinse each test tube with the appropriate working standard.
 - 12.3.3 Add exactly 10mL of each working standard to each test tube.
 - 12.3.4 Prepare 2 labeled test tubes with exactly 10 mL reagent water for the zero point in the calibration curve.
 - 12.3.5 Set aside 2 empty labeled test tubes to be digested with the batch with digestion reagent only (labeled RB).
 - 12.3.6 Prepare 2, 30mL labeled test tubes for glutamic/glycerophosphate for percent recovery by adding exactly 10mL to each test tube.
 - 12.3.7 Prepare 2, 30mL labeled test tubes for glutamic/glycerophosphate for CCV by adding exactly 10mL of the designated CCV solution to each test tube.

- 12.3.8 Thaw a Quality Control Sample (CRM) sample stored in freezer and sub-sample exactly 10mL into a labeled 30mL test tube to be used for QCS.
- 12.4 Prepare Digestion Reagent by dissolving 20.1 g Potassium Persulfate and 3 g Sodium Hydroxide in a 1000 mL volumetric flask:
- 12.4.1 Rinse volumetric flask with reagent water.
 - 12.4.2 Add 20.1 g Potassium Persulfate directly to the volumetric flask.
 - 12.4.3 Add reagent water until the meniscus is slightly below full volume.
 - 12.4.4 Add 3 g Sodium Hydroxide to the Potassium Persulfate and water solution, cap immediately and mix thoroughly.
 - 12.4.5 Bring to volume with reagent water.
 - 12.4.6 Make fresh daily.
 - 12.4.7 Digestion Reagent has a shelf life of about 4 hours.
- 12.5 When ready to digest, thaw frozen samples at room temperature.
- 12.6 Rinse dispensing vessel with reagent water and sample rinse with digestion reagent.
- 12.7 Add thoroughly mixed digestion reagent.
- 12.8 Set dispensing vessel for desired dispensing volume (Typically 5mL).
- 12.9 Add desired amount of digestion reagent, cap tube, shake for mixing and add test tube to pressure cooker.
- 12.10 Add desired amount of digestion reagent to the standards at the beginning and end of the sequence of loading the samples.
- 12.11 When all samples and standards have received digestion reagent and have been loaded into the pressure cooker, place pressure cooker on hot plate, add reagent water until tubes are 75% immersed, wet the gasket on the lid with a few drops of water and place lid on the pressure cooker.
- 12.12 Turn the hot plate on maximum temperature and have the pressure cooker come up to full steam. (This takes about 1 hour.)
- 12.13 When full steam is achieved, place the pressure regulator on the steam vent. Maintain heat for the cooker containing samples and standards at 3-4 psi for 55 minutes.
- 12.14 Turn off pressure cooker and unplug the hot plate when finished. Keep the lid on the pressure cooker.
- 12.15 After samples have cooled, usually the next day, remove the pressure cooker lid, add 1 mL Borate Buffer to each tube, cap, and shake.
- 12.16 Sample batch is now ready to analyze and is stable for 3 months.

13 DATA ANALYSIS AND CALCULATIONS

- 13.1 Upon completion of all analysis, results are saved to a daily report file. The file is named by the run date. The daily report file for analytical batch of January 3, 2015 would be named 010315. The file is saved to a Microsoft Excel file and then to a Lotus 123 file for data work up. The instrument

software has calculated final sample concentration from the designated standard curve, correcting each concentration for associated blank response and also for any user or instrument specified dilution. Dilution by the instrument is noted by software as analysis ensues and, also, documented in the Excel data report file. The analyst examines each row of data. Results are eliminated that are outside the limits of the calibration range, or have an unrepeated blank response measurement greater than 0.001 absorbance units.

14 REFERENCES

- 14.1 USEPA. 1979. Method No. 353.2 *in* Methods for chemical analysis of water and wastes. United States Environmental Protection Agency, Office of Research and Development. Cincinnati, Ohio. Report No. EPA-600/4-79-020 March 1979. 460pp.
- 14.2 Frank, J. M., C.F. Zimmermann and C. W. Keefe (2006). Comparison of results from Konelab Aquakem 250 and existing nutrient analyzers. UMCES CBL Nutrient Analytical Services Laboratory, Dec. 2006.
- 14.3 Strickland, J.D.H. and T.R. Parsons. 1965. A Manual of Sea Water Analysis, 2nd ed. Fisheries Research Board of Canada, Ottawa.

Range	umoles PO4/L	mg P/L	ml 2° PO4 std/100ml	Spike Conc.	Potassium Persulfate	CCV and % Recovery
	0	0	DI H2O			
TWS TDP	1.2	0.0372	1.0	2.5 ml of 400 umole NO3 &		
5 ml sample	2.4	0.0744	2.0	12 umole PO4	13.4 g/2000 mL and 2 g NaOH	2.0 mL Glycerophosphate
15 ml persulfate	6.0	0.186	5.0	Added to 2.5 ml	6.7 g/L and 1g NaOH	
	12.0	0.372	10.0	sample prior to digestion		
	0	0	DI H2O			
Low	0.12	0.0037	0.1	12 umole PO4		
10 ml sample	0.3	0.0093	0.25		20.1 g/L	1.0mL Glycerophosphate
5 ml persulfate	0.6	0.0186	0.5		and 3g/L NaOH	
	2.4	0.0744	2.0			
	4.8	0.1488	4.0			

Appendix 1. Methods and Standards Used for TDP Orthophosphate

UNIVERSITY OF MARYLAND CENTER FOR ENVIRONMENTAL SCIENCE
CHESAPEAKE BIOLOGICAL LABORATORY
NUTRIENT ANALYTICAL SERVICES LABORATORY
146 Williams St., Solomons MD 20688
<http://nasl.cbl.umces.edu/>

**Standard Operating Procedure for
Determination of Total Dissolved Phosphorus (TDP) and Total Phosphorus (TP) in
Fresh/Estuarine/Coastal Waters Using Alkaline Persulfate Digestion of Phosphorus
to Orthophosphate (PO₄)
(References Standard Methods #4500-P.B.5, #4500 P.E, and EPA Method 365.1)**

**Revision 2017-1
Replaces Revision 2015
Effective April 26, 2017**

Revised by: _____ Date: _____

Reviewed by: _____ Date: _____

Laboratory Supervisor: _____ Date: _____

Changes affecting Revision 2015

Section 1.1: Changed Phosphorus to phosphorus

Section 1.3: Inserted If more than seven replicates are used to determine the MDL, refer to the Student's *t* test table for the appropriate n-1 value.

Section 1.7: Used references instead of conforms

Section 2.1: Added (whole water for TP)

Entire Document: Changed Table 1 to Appendix 1

Section 3.5: Deleted preparation batch definition

Section 3.12.3: Added distinct from the ICV

Section 3.24: Deleted Instrument Detection Limit

Entire Document: Changed deionized water to reagent water

Section 3.25: Changed blank matrix to matrix blank

Section 3.27: Added This is also referred to as MDL.

Section 3.28: Added This is also referred to as the Quantitation Limit

Section 3.37: Changed proscribed to prescribed

Section 3.38: Added Also referred to as CRM

Section 3.41: Changed to word dips to lowers

Section 3.45: Added Also referred to as CRM

Section 4.1: Added samples are filtered for TDP

Section 5.1 Changed the word should to must, Changed CBL Business Manager to the CBL Associate Director of Administration and Facilities Maintenance

Section 5.4: Updated Chemical Safety Table (Table 1)

Section 7.4: Changed volumetric flask to polybottle

Section 7.5: Changed volumetric flask to glass bottle

Section 7.10: Changed KH₂PO₄ standard to be made in 500 ml instead of 1L, Added transfer to brown bottle and store in refrigerator

Section 7.13: Added make fresh every 6 months

Section 8.2: Added ≤ sign for freezer temp

Section 9.2.1: Changed the initial demonstration of capability acronym to IDOC

Section 9.2.2: Changed QCS checks from 10% to 3s

Section 9.2.3: Deleted from MDL description the change of operator or a new matrix is encountered, changed ambient water to natural water

Section 9.3.4: Added the words reagent blanks, deleted Set up an accuracy chart by using percent recovery since the concentration of the QCS/SRM varies

Section 9.3.5: Added ICV information to the CCV, Added See Appendix 1 for additional CCVs,

Changed TV to the expected value

Section 9.4: Changed % to read Percent

Section 9.7: Added Table 2

Section 10.1: Added the word digested

Section 10.3: Added the coefficient of determination (Pearson's *r* value) for the calibration curve as well as the calculated concentration of each calibrator is reviewed. The calculated value of each calibrator must be within ten percent of the expected value. The coefficient of determination (Pearson's *r* value) for the calibration curve must be greater than 0.998

Section 11.7: Added Analyze CRM sample at the beginning of the first group of samples

Section 11.10: Added At the end of the sample run, analyze CRM sample.

Section 12.3.6: Added labeled RB

Section 12.13: Changed digestion time to 55 minutes

Section 14: Deleted Method Performance section

Determination of Total Dissolved Phosphorus (TDP) and Total Phosphorus (TP) in Fresh/Estuarine/Coastal Waters Using Alkaline Persulfate Digestion of Phosphorus to Orthophosphate (PO₄)

1. SCOPE and APPLICATION

1.1 Potassium persulfate is used to oxidize organic and inorganic phosphorus to orthophosphate under heated acidic conditions.

1.2 Ammonium molybdate and potassium antimony tartrate react in an acid medium with dilute solutions of orthophosphate to form an antimony-phosphomolybdate complex which is reduced to an intensely blue-colored complex by ascorbic acid. Color is proportional to orthophosphate concentration. The method is used to analyze all ranges of salinity.

1.3 A method detection limit (MDL) of 0.0015 mg TDP as PO₄-P/L was determined using the Student's *t* value (3.14, n=7) times the standard deviation of a minimum of 7 replicates. If more than seven replicates are used to determine the MDL, refer to the Student's *t* test table for the appropriate n-1 value.

1.4 The Quantitation Limit for TDP as PO₄ was set at 0.0045 mg TDP as PO₄-P/L.

1.5 This procedure should be used by analysts experienced in the theory and application of aqueous organic and inorganic analysis. A three month training period with an analyst experienced in the analysis of TDP in aqueous samples is required.

1.6 This method can be used for all programs that require analysis of TDP.

1.7 This procedure references Standard Methods #4500-P.B.5, #4500 P.E, and EPA Method 365.1 (1979).

2. SUMMARY

2.1 An exact amount of filtered samples (whole water for TP) are placed in test tubes where an exact amount of Potassium Persulfate Digestion Reagent is added. Under initially alkaline conditions and heat, nitrate is the sole nitrogen product. As the potassium persulfate continues to oxidize, conditions become acidic and orthophosphate becomes the sole phosphorus product.

2.2 The now digested samples are buffered, then mixed with a sulfuric acid-molybdate solution, and subsequently with an ascorbic acid solution, yielding an intense blue color suitable for photometric measurement.

3. DEFINITIONS

3.1 Acceptance Criteria – Specified limits placed on characteristics of an item, process, or service defined in a requirement document. (ASQC)

3.2 Accuracy – The degree of agreement between an observed value and an accepted reference value. Accuracy includes a combination of

random error (precision) and systematic error (bias) components which are due to sampling and analytical operations; a data quality indicator. (QAMS)

- 3.3 Aliquot – A discrete, measured, representative portion of a sample taken for analysis. (EPA QAD Glossary)
- 3.4 Analytical Range – There are multiple analytical ranges/standard curves used for determination of TDP. See Appendix 1 for all analytical ranges used.
- 3.5 Batch – Environmental samples, which are prepared and /or analyzed together with the same process and personnel, using the same lot(s) of reagents. An **analytical batch** is composed of prepared environmental samples (extracts, digestates, or concentrates) and/or those samples not requiring preparation, which are analyzed together as a group using the same calibration curve or factor. An analytical batch can include samples originating from various environmental matrices and can exceed 20 samples. (NELAC/EPA)
- 3.6 Blank- A sample that has not been exposed to the analyzed sample stream in order to monitor contamination during sampling, transport, storage or analysis. The blank is subjected to the usual analytical and measurement process to establish a zero baseline or background value and is sometimes used to adjust or correct routine analytical results. (ASQC)
- 3.7 Calibrate- To determine, by measurement or comparison with a standard, the correct value of each scale reading on a meter or other device, or the correct value for each setting of a control knob. The levels of the applied calibration standard should bracket the range of planned or expected sample measurements. (NELAC)
- 3.8 Calibration – The set of operations which establish, under specified conditions, the relationship between values indicated by a measuring device. The levels of the applied calibration standard should bracket the range of planned or expected sample measurements. (NELAC)
- 3.9 Calibration Blank – A volume of reagent water fortified with the same matrix as the calibration standards, without the analyte added.
- 3.10 Calibration Curve – The graphical relationship between known values, such as concentrations, or a series of calibration standards and their analytical response. (NELAC)
- 3.11 Calibration Method – A defined technical procedure for performing a calibration. (NELAC)
- 3.12 Calibration Standard – A substance or reference material used to calibrate an instrument. (QAMS)
 - 3.12.1 Initial Calibration Standard (STD) – A series of standard solutions used to initially establish instrument calibration responses and develop calibration curves for individual target analytes.
 - 3.12.2 Initial Calibration Verification (ICV) – An individual standard, analyzed initially, prior to any sample analysis,

which verifies acceptability of the calibration curve or previously established calibration curve.

- 3.12.3 Continuing Calibration Verification (CCV) – An individual standard, distinct from the ICV, which is analyzed after every 18-23 field sample analysis.
- 3.13 Certified Reference Material (CRM)– A reference material one or more of whose property values are certified by a technically valid procedure, accompanied by or traceable to a certificate or other documentation which is issued by a certifying body. (ISO 17025)
- 3.14 Colorimeter – Detector found in Bran & Luebbe Single-Channel Industrial Colorimeter. Color is quantitatively detected with 199-B021-04 phototubes using 880 nm monochromatic filters and 50 mm long flow cell with 1.5 mm internal diameter. Comparisons are made between signals from the colored solution in the flow cell to the signal of air in the reference cell. Signals from the Colorimeter are transmitted to a Recorder.
- 3.15 Corrective Action – Action taken to eliminate the causes of an existing nonconformity, defect or other undesirable situation in order to prevent recurrence. (ISO 8402)
- 3.16 Deficiency – An unauthorized deviation from acceptable procedures or practices. (ASQC)
- 3.17 Demonstration of Capability – A procedure to establish the ability of the analyst to generate acceptable accuracy. (NELAC)
- 3.18 Detection Limit – The lowest concentration or amount of the target analyte that can be determined to be different from zero by a single measurement at a stated degree of confidence.
- 3.19 Duplicate Analysis – The analyses of measurements of the variable of interest performed identically on two sub samples (aliquots) of the same sample. The results from duplicate analyses are used to evaluate analytical or measurement precision but not the precision of sampling, preservation or storage internal to the laboratory. (EPA-QAD)
- 3.20 External Standard (ES) – A pure analyte (potassium phosphate (KH_2PO_4)) that is measured in an experiment separate from the experiment used to measure the analyte(s) in the sample. The signal observed for a known quantity of the pure external standard is used to calibrate the instrument response for the corresponding analyte(s). The instrument response is used to calculate the concentrations of the analyte(s) in the unknown sample.
- 3.21 Field Duplicates (FD1 and FD2) – Two separate samples collected at the same time and place under identical circumstances and treated exactly the same throughout field and laboratory procedures. Analyses of FD1 and FD2 provide a measure of the precision associated with sample collection, preservation and storage, as well as with laboratory procedures.
- 3.22 Field Reagent Blank (FRB) – An aliquot of reagent water or other blank matrix that is placed in a sample container in the laboratory and

treated as a sample in all respects, including shipment to the sampling site, exposure to the sampling site conditions, storage, preservation, and all analytical procedures. The purpose of the FRB is to determine if method analytes or other interferences are present in the field environment.

- 3.23 Holding time – The maximum time that samples may be held prior to analysis and still be considered valid. (40 CFR Part 136) The time elapsed from the time of sampling to the time of extraction or analysis, as appropriate.
- 3.24 Laboratory Duplicates (LD1 and LD2) – Two aliquots of the same sample taken in the laboratory and analyzed separately with identical procedures. Analyses of LD1 and LD2 indicate precision associated with laboratory procedures, but not with sample collection, preservation, or storage procedures.
- 3.25 Laboratory Reagent Blank (LRB) – A matrix blank (i.e., reagent water) that is treated exactly as a sample including exposure to all glassware, equipment, solvents, and reagents that are used with other samples. The LRB is used to determine if method analytes or other interferences are present in the laboratory environment, the reagents, or the instrument.
- 3.26 Laboratory Control Sample (LCS) – A sample matrix, free from the analytes of interest, spiked with verified known amounts of analytes from a source independent of the calibration standard or a material containing known and verified amounts of analytes. The LCS is generally used to establish intra-laboratory or analyst-specific precision and bias or to assess the performance of all or a portion of the measurement system. (NELAC)
- 3.27 Limit of Detection (LOD) – The lowest concentration level that can be determined by a single analysis and with a defined level of confidence to be statistically different from a blank. This is also referred to as MDL. (ACS)
- 3.28 Limit of Quantitation (LOQ) – The minimum levels, concentrations, or quantities of a target variable (target analyte) that can be reported with a specified degree of confidence. The LOQ is set at 3 to 10 times the LOD, depending on the degree of confidence desired. . This is also referred to as the Quantitation Limit.
- 3.29 Linear Dynamic Range (LDR) – The absolute quantity over which the instrument response to an analyte is linear. This specification is also referred to as the Linear Calibration Range (LCR).
- 3.30 Manifold – The module whose configuration of glass connectors, fittings, mixing coils, tubing and 37° C heating bath precisely reduces the antimony-phospho-molybdate complex to an intensely blue-colored complex by ascorbic acid to orthophosphate.
- 3.31 Material Safety Data Sheets (MSDS) – Written information provided by vendors concerning a chemical’s toxicity, health hazards,

physical properties, fire, and reactivity data including storage, spill, and handling precautions.

- 3.32 May – Denotes permitted action, but not required action. (NELAC)
- 3.33 Method Detection Limit (MDL) – The minimum concentration of an analyte that can be identified, measured, and reported with 99% confidence that the analyte concentration is greater than zero. (Standard Methods)
- 3.34 Must – Denotes a requirement that must be met. (Random House College Dictionary)
- 3.35 Precision – The degree to which a set of observations or measurements of the same property, obtained under similar conditions, conform to themselves; a data quality indicator. Precision is usually expressed as standard deviation, variance or range, in either absolute or relative terms. (NELAC)
- 3.36 Preservation – Refrigeration, freezing, and/or reagents added at the time of sample collection (or later) to maintain the chemical and or biological integrity of the sample.
- 3.37 Proportioning Pump – A peristaltic pump that mixes and advances samples and reagents through prescribed precision pump tubes proportionately for the reactions to take place and for the concentration to be measured.
- 3.38 Quality Control Sample (QCS) – A sample of analyte of known and certified concentration. The QCS is obtained from a source external to the laboratory and different from the source of calibration standards. It is used to check laboratory performance with externally prepared test materials. Also referred to as CRM.
- 3.39 Recorder – A graphic recorder used to record electronic output from the colorimeter.
- 3.40 Run Cycle – Typically a day of operation – the entire analytical sequence from sampling the first standard to the last sample of the day.
- 3.41 Sampler – An automated rotational device that moves sample cups sequentially to aspirate an aliquot into the proscribed analytical stream. As the loaded sample tray rotates, a metal probe lowers into the sample cup and aspirates sample for a preset time, rises from the sample cup and aspirates air for approximately one second and goes into a reagent water-filled wash receptacle, where reagent water is aspirated. After another preset interval, the probe rises from the wash receptacle, aspirates air and moves into the next sample cup. The sampler moves at a rate of 40 samples per hour with a sample to wash solution ratio of 9:1.
- 3.42 Sensitivity – The capability of a test method or instrument to discriminate between measurement responses representing different levels (concentrations) of a variable of interest.

- 3.43 Shall – Denotes a requirement that is mandatory whenever the criterion for conformance with the specification requires that there be no deviation. (ANSI)
- 3.44 Should – Denotes a guideline or recommendation whenever noncompliance with the specification is permissible. (ANSI)
- 3.45 Standard Reference Material (SRM) – Material which has been certified for specific analytes by a variety of analytical techniques and/or by numerous laboratories using similar analytical techniques. These may consist of pure chemicals, buffers, or compositional standards. The materials are used as an indication of the accuracy of a specific analytical technique. Also referred to as CRM.











4 INTERFERENCES

- 4.1 Suspended matter in the sample will restrict flow through the apparatus. All samples must be filtered for TDP. See Section 8.
- 4.2 High silica concentrations cause positive interferences. Silicon at a concentration of 100 μ M Si causes interferences equivalent to approximately 0.04 μ M P.

5 SAFETY

- 5.1 Safety precautions must be taken when handling reagents, samples and equipment in the laboratory. Protective clothing including lab coats, safety glasses and enclosed shoes must be worn. In certain situations, it will be necessary to also use gloves and/or a face shield. If solutions come in contact with eyes, flush with water continuously for 15 minutes. If solutions come in contact with skin, wash thoroughly with soap and water. Contact Solomons Rescue Squad (911) if emergency treatment is needed and also inform the CBL Associate Director of Administration and Facilities Maintenance of the incident. Contact the CBL Associate Director of Administration and Facilities Maintenance if additional treatment is required.
- 5.2 The toxicity or carcinogenicity of each reagent used in this procedure may not have been fully established. Each chemical should be regarded as a potential health hazard and exposure should be as low as reasonably achievable. Cautions are included for known hazardous materials and procedures.
- 5.3 Do not wear jewelry when troubleshooting electrical components. Even low voltage points are dangerous and can injure if allowed to short circuit.
- 5.4 The following hazard classifications are listed for the chemicals used in this procedure. Detailed information is provided on Material Safety Data Sheets (MSDS).

Table 1

Chemical	Health Hazard	Fire Hazard	Instability Hazard	Specific Hazard	
Sodium Hydroxide	3	0	1	ALK, COR	
Sulfuric Acid	4	0	2	ACID, COR	
Ammonium molybdate	4	0	1	Irritant	
Ascorbic Acid	1	0	0	ACID	
Potassium antimonyl tartrate hemihydrate	2	0	0		
Potassium dihydrogen phosphate	2	0	0		
Chloroform	3	0	0		
Hydrochloric Acid	3	0	2	ACID, COR	
Acetone	1	3	0		
Clorox	3	0	0		
Potassium Persulfate	2	0	2	OXY	
Boric Acid	2	0	0		
Sodium dodecyl sulfate (SDS)					

On a scale of 0 to 4 the substance is rated on four hazard categories: health, flammability, reactivity, and contact. (0 is non-hazardous and 4 is extremely hazardous)

HAZARD RATING

Health Hazard - Blue: 4 – deadly, 3 – extreme danger, 2 – hazardous, 1 – slightly hazardous, 0 – normal material

Fire Hazard - Red: Flash Points: 4 – below 73° F, 3 – below 100° F, 2 – below 200° F, 1 – above 200° F, 0 – will not burn

Instability Hazard - Yellow: 4 – may detonate, 3 – Shock and heat may detonate, 2 – violent chemical change, 1 – unstable is heated, 0 - stable

Specific Hazard - White: Acid = ACID, Alkali = ALK, Corrosive = COR, Oxidizer = OXY

6 EQUIPMENT AND SUPPLIES

- 6.1 Technicon Bran & Luebbe AutoAnalyzer II (now owned by Seal Analytical) sampler, proportioning pump, manifold and colorimeter capable of analyzing for TDP as orthophosphate are used in this laboratory. A PMC Industries Flat Bed Linear recorder is used to record electronic output from the colorimeter.
- 6.2 Freezer, capable of maintaining $-20 \pm 5^{\circ} \text{C}$.
- 6.3 Lab ware – All reusable lab ware (glass, Teflon, plastic, etc) should be sufficiently clean for the task objectives. This laboratory cleans all lab ware related to this method with a 10% HCl (v/v) acid rinse. This laboratory cleans all lab ware that has held solutions containing ammonium molybdate with 10% NaOH (w/v) rinse.
- 6.4 Pressure Cooker with pressure regulator and pressure gauge.
- 6.5 Hot plate with variable heat settings.

7 REAGENTS AND STANDARDS

- 7.1 Purity of Water – Unless otherwise indicated, references to water shall be understood to mean reagent water conforming to Specification D 1193, Type I. Freshly prepared water should be used for making the standards intended for calibration. The detection limits of this method will be limited by the purity of the water and reagents used to make the standards.
- 7.2 Purity of Reagents – Reagent grade chemicals shall be used in all tests. Unless otherwise indicated, it is intended that all reagents shall conform to specifications of the Committee on Analytical Reagents of the American Chemical Society, where such specifications are available. Other grades may be used, provided it is first ascertained that the reagent is of sufficiently high purity to permit its use without compromising the accuracy of the determination.
- 7.3 4.9 N Sulfuric Acid

Sulfuric Acid (concentrated H ₂ SO ₄)	136mL
Reagent water	up to 1000 mL

In a 1000 mL volumetric flask, add approximately 700 mL reagent water. Add 136mL H₂SO₄ to the reagent water, let cool, and bring to volume.

Write the name of preparer, preparation date, reagent manufacturer, manufacturer lot number in the Analytical Reagent log book. The reagent is stable for one year.

7.4 Ammonium molybdate solution

Ammonium molybdate	8 g
Reagent water	up to 200 mL

In a 500 mL plastic polybottle, dissolve, with immediate inversion, 8 g of ammonium molybdate, in 200 mL reagent water. . Store polybottle in the dark at room temperature. Write the name of preparer, preparation date, reagent manufacturer, manufacturer lot number in the Analytical Reagent log book. The reagent is stable for one month. Discard if white precipitate appears in bottle or on threads of cap.

7.5 Potassium antimonyl tartrate solution

Potassium antimonyl tartrate	0.6 g
------------------------------	-------

In a 500 mL glass bottle dissolve 0.6g potassium antimonyl tartrate hemihydrate, in 200 mL reagent water. Store glass bottle at room temperature. Write the name of preparer, preparation date, reagent manufacturer, manufacturer lot number in the Analytical Reagent log book. Reagent is stable for one year.

7.7 Ascorbic acid solution

Ascorbic Acid	1.8 g
---------------	-------

In a 100 mL plastic volumetric flask dissolve 1.8 g ascorbic acid in approximately 90 mL reagent water. Bring flask up to volume. Store flask in refrigerator. Write the name of preparer, preparation date, reagent manufacturer, manufacturer lot number in the Analytical Reagent log book. Reagent is stable for two months.

7.8 Triple Reagent

4.9 N Sulfuric Acid	75 mL
Ammonium molybdate solution	22.5 mL
Potassium antimonyl tartrate solution	7.5 mL
SDS	0.15 g

Add 0.15 g SDS to a 200 mL Erlenmeyer glass flask. Add 75 mL sulfuric acid to the flask. Carefully add 22.5 mL ammonium molybdate solution to the flask. Carefully add 7.5 mL potassium antimonyl tartrate solution to the flask. Carefully swirl the flask to mix the reagent together. Triple reagent is made and used on the day of analysis only.

7.9 Working Ascorbic acid solution

Ascorbic Acid	50 mL
SDS	0.1 g

In a plastic 50 mL beaker, add 0.1 g SDS. Pour in approximately 30 mL Ascorbic acid solution and swirl. When SDS is dissolved, fill beaker up to 50 mL with ascorbic acid solution. When analysis is complete, cover

remaining working ascorbic acid solution with parafilm and store in refrigerator. Reagent is stable for one month.

7.10 Orthophosphate Stock Standard, 12,000 μM –
Potassium dihydrogen phosphate (KH_2PO_4), primary standard
grade, dried at 45 C 0.816 g
Reagent water up to 500 mL

In a 500 mL volumetric flask, dissolve 0.816 g of potassium dihydrogen phosphate in approximately 400 mL reagent water. Bring flask to volume with reagent water (1mL contains 12 $\mu\text{moles P}$). Add 1 mL chloroform as a preservative. Transfer to a brown bottle and store in refrigerator. Write the name of preparer, preparation date, reagent manufacturer, manufacturer lot number in the Analytical Reagent log book. Make fresh every 6 months.

7.11 Secondary Orthophosphate Standard –
Stock Orthophosphate Standard 1.0 mL
Reagent water up to 100 mL

In a 100 mL volumetric flask, dilute 1.0 mL of Stock Orthophosphate Standard to 100 mL with reagent water to yield a concentration of 120 $\mu\text{M PO}_4\text{-P/L}$ (1 mL contains 1.2 $\mu\text{moles P}$). Store flask in refrigerator. Write the name of preparer, preparation date, reagent manufacturer, manufacturer lot number in the Analytical Standard log book. Make fresh every 4 weeks.

7.12 Working Orthophosphate Standards for TDP – See Appendix 1 for all working Orthophosphate Standards for TDP Working Orthophosphate Standards for TDP are made with Secondary Orthophosphate Standard. Write the name of preparer, preparation date, reagent manufacturer, manufacturer lot number in the Analytical Standard log book. Make fresh for every digestion batch.

7.13 Glycerophosphate Stock Standard –
B-Glycerophosphoric acid, disodium salt, 5 hydrate 0.0473 g
Reagent water up to 500 mL
Chloroform (CHCl_3) 0.5 mL

In a 500 mL volumetric flask, dissolve 0.0473 g of glycerophosphoric acid in about 400 mL of reagent water and dilute to 500 mL with reagent water. Add 0.5 mL of chloroform as a preservative. Write the name of preparer, preparation date, reagent manufacturer, manufacturer lot number in the Analytical Standard log book. Make fresh every 6 months.

7.14 Working Glycerophosphate Standard for TDP – See Appendix 1 for all working glycerophosphate Standards for TDP.

Write the name of preparer, preparation date, reagent manufacturer, manufacturer lot number in the Analytical Standard log book. Make fresh for every digestion batch.

7.15 Potassium Persulfate Digestion Reagent –	
Sodium Hydroxide (NaOH)	3 g
Potassium Persulfate (K ₂ S ₂ O ₈), Low N	20.1 g
Reagent water	up to 1000 mL

In a 1000 mL volumetric flask, dissolve 3g of sodium hydroxide and 20.1 g of potassium persulfate in ~800mL of reagent water. Dilute to 1000 mL with reagent water. Write the name of preparer, preparation date, reagent manufacturer, manufacturer lot number in the Analytical Reagent log book. Make fresh daily.

7.16 Borate Buffer Solution –	
Boric Acid (H ₃ BO ₃)	61.8 g
Sodium Hydroxide (NaOH)	8 g
Reagent water	up to 1000 mL

In a 1000 mL volumetric flask, dissolve 61.8 g of boric acid in ~ 300mL reagent water. Add 8g of sodium hydroxide and dilute to 1000mL with reagent water. Write the name of preparer, preparation date, reagent manufacturer, manufacturer lot number in the Analytical Reagent log book. Make fresh every 4 months.

8 SAMPLE COLLECTION, PRESERVATION, AND STORAGE

- 8.1 Water collected for TDP should be filtered through a Whatman GF/F glass fiber filter (nominal pore size 0.7 µm), or equivalent.
- 8.2 Prior to initial use, capped 30 mL test tubes must be digested with Digestion Reagent, then rinsed thoroughly with reagent water following laboratory glassware cleaning methods.
- 8.3 A prescribed amount (typically 10mL) of sample should be added to each sample rinsed, capped 30mL test tube.
- 8.4 Water collected for TDP should be frozen at ≤-20° C.
- 8.5 Frozen TDP samples may be stored longer than 28 days. It has been shown that frozen QCS samples up to a year old still fall well within the control limits.
- 8.6 Digested TDP samples may be stored up to three months.
- 8.7 TDP samples may be refrigerated at 4° C for no longer than one day.

9 QUALITY CONTROL

- 9.1 The laboratory is required to operate a formal quality control (QC) program. The minimum requirements of this program consist of an initial demonstration of laboratory capability and the continued analysis of laboratory instrument

blanks and calibration standard material, analyzed as samples, as a continuing check on performance. The laboratory is required to maintain performance records that define the quality of data generated.

9.2 Initial Demonstration of Capability

- 9.2.1 The initial demonstration of capability (iDOC) – is used to characterize instrument performance (MDLs) and laboratory performance (analysis of QC samples) prior to the analyses conducted by this procedure.
- 9.2.2 Quality Control Sample (QCS/SRM) – When using this procedure, a quality control sample is required to be analyzed during the run, to verify data quality and acceptable instrument performance. If the determined concentrations are not within $\pm 3s$ of the certified values, performance of the determinative step of the method is unacceptable. The source of the problem must be identified and corrected before either proceeding with the initial determination of MDLs or continuing with analyses.
- 9.2.3 Method Detection Limits (MDLs) – MDLs should be established for TDP using a low level natural water sample, typically three to five times higher than the estimated MDL. To determine the MDL values, analyze seven replicate aliquots of water and process through the entire analytical procedure. Perform all calculations defined in the procedure (Sections 11.6-11.8 and Section 13) and report the concentration values in the appropriate units. Calculate the MDL as follows:

$$\text{MDL} = S t_{(n-1, 1-\alpha=0.99)}$$

Where,

S = Standard deviation of the replicate analyses.

n=number of replicates

$t_{(n-1, 1-\alpha=0.99)}$ = Student's *t* value for the 99% confidence level with n-1 degrees of freedom ($t=3.14$ for 7 replicates.)

- 9.2.4 MDLs should be determined annually, whenever there is a significant change in instrumental response or a significant change in instrument configuration

9.3 Assessing Laboratory Performance

- 9.3.1 Laboratory Reagent Blank (LRB) – The laboratory must analyze at least one LRB with each batch of samples. The LRB consists of reagent water treated the same as the samples. An amount of analyte above the MDL (TDP) found in LRB indicates possible reagent or laboratory environment contamination. LRB data are used to assess and correct contamination from the laboratory environment.

- 9.3.2 Quality Control Sample (QCS)/ Standard Reference Material (SRM)
– When using this procedure, a quality control sample is required to be analyzed at the beginning of the run and end of the run, to verify data quality and acceptable instrument performance. If the determined concentrations are not within $\pm 3s$ of the certified values, performance of the determinative step of the method is unacceptable. The source of the problem must be identified and corrected before either proceeding with the initial determination of MDLs or continuing with the analyses. The results of these QCS/SRM samples shall be used to determine sample batch acceptance.
- 9.3.3 The QCS are obtained from a source external to the laboratory and different from the source of calibration standards.
- 9.3.4 Control Charts – The Accuracy Control Chart for QCS/SRM samples and digested reagent blanks is constructed from the average and standard deviation of the 20 most recent QCS/SRM measurements. The accuracy chart includes upper and lower warning levels ($WL=\pm 2s$) and upper and lower control levels ($CL=\pm 3s$). These values are derived from stated values of the QCS/SRM. The standard deviation (s) is specified relative to statistical confidence levels of 95% for WLs and 99% for CLs. Enter QCS/SRM results on the chart each time the sample is analyzed.
- 9.3.5 Calibration Verification, Initial and Continuing (ICV/CCV) – Immediately following calibration (ICV) and following every 18-23 samples (CCV), two calibration verifications are analyzed to assess instrument performance. The CCVs are made from the different material than the calibration standards (KH_2PO_4), and are to be within the expected value $\pm 3s$. Failure to meet the criteria requires correcting the problem, including reanalysis of any affected samples. If not enough sample exists, the data must be qualified if reported. Specific CCV's can be found in Appendix 1.

9.4 Assessing Analyte Recovery -Percent Recovery

- 9.4.1 Analyte recovery is assessed through percent recoveries of laboratory spikes. Analyte recovery is also assessed through the percent recovery of an organic standard that was digested with each batch of samples.
- 9.4.2 Percent Recovery = (Actual/Expected) x 100

9.5 Assessing Analyte Precision – Relative Percent Difference (RPD)

- 9.5.1 Analyte replication is assessed through duplicate analyses of samples – Relative Percent Difference.
- 9.5.2 $RPD = \frac{\text{Laboratory Duplicate Result 1} - \text{Laboratory Duplicate Result 2}}{[\text{Laboratory Duplicate Result 1} + \text{Laboratory Duplicate Result 2}]/2} \times 100$

9.6 Corrective Actions for Out of Control Data

- 9.6.1 Control limit – If one measurement exceeds Accuracy Control Chart CL, repeat the analysis immediately. If the repeat measurement is within the CL, continue analyses; if it exceeds the CL, discontinue analyses and correct the problem.
- 9.6.2 Warning limit – If two out of three successive points exceed Accuracy Control Chart WL, analyze another sample. If the next point is within WL, continue analyses; if the next point exceeds the WL, evaluate potential bias and correct the problem.
- 9.6.3 Trending – If seven successive Accuracy Control Chart measurements are on the same side of the central line, discontinue analyses and correct the problem.
- 9.6.4 When external QCS samples are out of control, correct the problem. Reanalyze the samples analyzed between the last in-control measurement and the out-of-control one.
- 9.6.5 When external CCV samples are out of control, correct the problem. Reanalyze the samples analyzed between the last in-control measurement and the out-of-control one.

9.7 General Operation - To assure optimal operation and analytical results, the Reagent Blank (LRB) and CCV are tracked daily in the raw data file, copied to Reagent Blank (LRB) and CCV Control Charts.

Table 2

QC Indicator	Acceptance/ Action Limits	Action	Frequency (Batch)
Correlation Coefficient	≥ 0.998	If <0.998, evaluate data points of the calibration curve. If any data point is outside established limits, reject as outlier.	1 per batch if acceptable.
Quality Control Sample (QCS)/ Certified Reference Material (CRM)	± 10%	If QCS value is outside ± 10% of the target value reject the run, correct the problem and rerun samples.	Beginning of run and at end of run.
Initial Calibration Verification (ICV)	± 10%	Recalibrate if outside acceptance limits.	Beginning of run following standard curve.
Continuing Calibration Verification (CCV)	± 10%	If outside 10%, correct the problem. Rerun all samples following the last in-control CCV.	After every 18-23 samples.
Method Blank/Laboratory Reagent Blank	≤ Method Quantitation Limit	If the LRB exceeds the quantitation limit, results are suspect. Rerun the LRB. If	Following the ICV and after every 18-23

(LRB)		the concentration still exceeds the quantitation limit, reject or qualify the data, or raise the quantitation limit.	samples following the CCV.
Laboratory Fortified Sample Matrix Spike	± 10%	If the recovery of any analyte falls outside the designated acceptance limits and the QCS is in control, the recovery problem is judged matrix induced. Repeat the LFM and if the sample results are again outside the acceptable recovery range, the sample should be reported with a “matrix induced bias” qualifier.	1/10 (spike OR duplicate)
Laboratory Duplicate	± 10%	If the RPD fails to meet the acceptance limits, the samples should be reanalyzed. If the RPD again fails to meet the acceptance limits, the sample must be reported with a qualifier identifying the sample analysis result as not having acceptable RPD for duplicate analysis.	1/10 (spike OR duplicate)

10 CALIBRATION AND STANDARDIZATION

10.1 Calibration – Daily calibration must be performed before sample analysis may begin. Four point calibrations are used with the Technicon Bran & Luebbe AutoAnalyzer II in replicates of three. ASTM Type I digested water is used as the zero point in the calibration.

10.2 Working TDP Standards –Appendix 1 defines all working TDP Standards.

10.3 Prepare standard curve by plotting response on recorder of standards processed through the manifold against TDP as PO₄ –P/L concentration in standards.

Compute sample mg TDP/L concentration by comparing sample response on recorder with standard curve. The coefficient of determination (Pearson’s r value) for the calibration curve as well as the calculated concentration of each calibrator is reviewed. The calculated value of each calibrator must be within ten percent of

the expected value. The coefficient of determination (Pearson's r value) for the calibration curve must be greater than 0.998.

11 PROCEDURE – DAILY OPERATION

- 11.1 Attach pump tubes to end rails of Proportioning Pump. Put platen on Proportioning Pump. Allow reagent water to run through the sample line, reagent water mixed with SDS to run through the diluent line and reagent water mixed with SDS to run through both the Ascorbic Acid and Triple Reagent lines. Check for good flow characteristics (good bubble pattern).
- 11.2 Turn on Colorimeter and Recorder. Set Colorimeter Standard Calibration setting to 1.00. Let liquid pump through the Manifold and Colorimeter for 15 minutes.
- 11.3 At the conclusion of the 15 minutes, turn Baseline Knob on Colorimeter to obtain 5 chart units deflection on Recorder.
- 11.4 Insert the Ascorbic Acid line into the Ascorbic Acid solution and the Triple Reagent line into the Triple Reagent solution. At a Colorimeter Standard Calibration setting of 1.00, note deflection on the Recorder. Reject Triple Reagent if deflection is more than 8 out of total 100 chart units. Turn Baseline Knob on the Colorimeter to obtain 0 deflection on Recorder.
- 11.5 At desired Standard Calibration (See Appendix 1), analyze inorganic linearity check. Repeat the top standard to check for good replication. If replicates are not within $\pm 10\%$, repeat. If repeating fails a second time, remake Triple Reagent components and Triple Reagent solution.
- 11.6 Analyze Working TDP Standards using the NAP Software Program. (For NAP Software Program procedures, see Appendix 2.) The NAP Software Program will prepare standard curve by plotting response on recorder of standards processed through the manifold against TDP as $\text{PO}_4\text{-P/L}$ concentration in standards.
- 11.7 Analyze CRM sample at the beginning of the first group of samples.
- 11.8 Analyze samples. The NAP Software Program will compute sample TDP as $\text{PO}_4\text{-mg P/L}$ concentration by comparing sample response on Recorder with standard curve.
- 11.9 Change the Standard Calibration setting if a sample peak is larger than 100%. Standard Calibration setting of 8.0 can be turned down to 5.0, then 2.0 and finally 1.0. Calculate the Change in Gain by multiplying the peak height times $100/55.5$ for correcting to a Standard Calibration of 5.0, $100/55.5 \times 100/47.6$ for correcting to a Standard Calibration of 2.0, and $100/55.5 \times 100/47.6 \times 100/66.6$ for correcting to a Standard Calibration of 1.0. This will give a corrected peak height. Use the corrected peak height with the daily regression in order to calculate the sample concentration in mg/L.
- 11.10 At the end of the sample run, analyze CRM sample.
- 11.11 Allow reagent water to flow through the sample line for 10 minutes. Allow reagent water to flow through the sample, Ascorbic Acid and Triple Reagent lines for one minute. Turn Proportioning Pump switch to fast pump for its allotted time.

- 11.12 Turn off Sampler, Colorimeter and Recorder. Release and remove Proportioning Pump platen. Release pump tubes from end rails.

12 PROCEDURE – SAMPLE DIGESTION

- 12.1 TDN/TDP samples are digested simultaneously in the same ampule. In our procedures, this ampule is a 30 mL screw cap test tube.
- 12.2 Prepare working standards, QCS (CRM), and CCV in labeled 100 mL volumetric flasks:
 - 12.2.1 Select concentration range for both TDN/TDP that best fits the sample batch from Appendix 1.
 - 12.2.2 Fill 100 mL volumetric flasks with 80 mL reagent water.
 - 12.2.3 Add appropriate amount of KNO_3 and KH_2PO_4 to each labeled working standard volumetric flask from Appendix 1.
 - 12.2.4 Add appropriate amount of glutamic/glycerophosphate to each labeled CCV and percent recovery volumetric flask from Appendix 1.
 - 12.2.5 Bring up to 100 mL volume with reagent water.
 - 12.2.6 Mix each 100 mL labeled volumetric flask thoroughly.
- 12.3 Sub-sample working standards into 30mL screw cap test tubes:
 - 12.3.1 Prepare 3, 30mL labeled test tubes for each working standard concentration.
 - 12.3.2 Sample rinse each test tube with the appropriate working standard.
 - 12.3.3 Add exactly 10mL of each working standard to each test tube.
 - 12.3.4 Prepare 3 labeled test tubes with exactly 10 mL reagent water for “0” in the calibration curve.
 - 12.3.5 Set aside 3 empty labeled test tubes to be digested with the batch with digestion reagent only (labeled RB).
 - 12.3.6 Prepare 2, 30mL labeled test tubes for glutamic/glycerophosphate for percent recovery by adding exactly 10mL to each test tube.
 - 12.3.7 Prepare 2, 30mL labeled test tubes for glutamic/glycerophosphate for CCV by adding exactly 10mL of the designated CCV solution to each test tube.
 - 12.3.8 Thaw a Quality Control Sample (CRM) sample stored in freezer and sub-sample exactly 10mL into a labeled 30mL test tube to be used for QCS.
- 12.4 Prepare Digestion Reagent by dissolving 20.1 g Potassium Persulfate and 3 g Sodium Hydroxide in a 1000 mL volumetric flask:
 - 12.4.1 Rinse volumetric flask with reagent water.
 - 12.4.2 Add 20.1 g Potassium Persulfate directly to the volumetric flask.
 - 12.4.3 Add reagent water until the meniscus is slightly below full volume.

- 12.4.4 Add 3 g Sodium Hydroxide to the Potassium Persulfate and water solution, cap immediately and mix thoroughly.
- 12.4.5 Bring to volume with reagent water.
- 12.4.6 Make fresh daily.
- 12.4.7 Digestion Reagent has a shelf life of about 4 hours.

- 12.5 When ready to digest, thaw frozen samples at room temperature.
- 12.6 Rinse dispensing vessel with reagent water and sample rinse with digestion reagent.
- 12.7 Add thoroughly mixed digestion reagent.
- 12.8 Set dispensing vessel for desired dispensing volume (Typically 5mL).
- 12.9 Add desired amount of digestion reagent, cap tube, shake for mixing and add test tube to pressure cooker.
- 12.10 Add desired amount of digestion reagent to the standards at the beginning, middle and end of the sequence of loading the samples.
- 12.11 When all samples and standards have received digestion reagent and have been loaded into the pressure cooker, place pressure cooker on hot plate, add reagent water until tubes are 75% immersed, wet the gasket on the lid with a few drops of water and place lid on the pressure cooker.
- 12.12 Turn the hot plate on maximum temperature and have the pressure cooker come up to full steam. (This takes about 1 hour.)
- 12.13 When full steam is achieved, place the pressure regulator on the steam vent. Maintain heat for the cooker containing samples and standards at 3-4 psi for 55 minutes.
- 12.14 Turn off pressure cooker and unplug the hot plate when finished. Keep the lid on the pressure cooker.
- 12.15 After samples have cooled, usually the next day, remove the pressure cooker lid, add 1 mL Borate Buffer to each tube, cap, and shake.
- 12.16 Sample batch is now ready to analyze and is stable for 3 months.

13 DATA ANALYSIS AND CALCULATIONS

- 13.1 Upon completion of all analysis, results are saved to a Lotus 123 daily report file. The file is named by the run date. The daily report file for analytical batch of January 3, 2015 would be named 010315tdnp. The instrument software has calculated final sample concentration from the designated standard curve in a program called New Analyzer Program (NAP) Software. Dilution by the analyst is noted and recalculated by multiplying the original peak height times the dilution factor to calculate a corrected peak height. Use the corrected peak height with the daily regression to calculate the sample concentration in mg/L. The analyst examines each peak height and peak marker within the NAP Software and compares it to the peak height from the chart recorder, correcting the placement of the peak marker if necessary. Results are eliminated that are outside the limits of the calibration range.

14 REFERENCES

- 14.1 Technicon Industrial Method No. 158-71 W/A Tentative. 1977. Technicon Industrial Systems. Tarrytown, New York, 10591.
- 14.2 USEPA. 1979. Method No. 353.2 *in* Methods for chemical analysis of water and wastes. United States Environmental Protection Agency, Office of Research and Development. Cincinnati, Ohio. Report No. EPA-600/4-79-020 March 1979. 460pp.

Range	Pump Tubes	umoles PO4/L	mg P/L	ml 2° PO4 std/100ml	Spike Conc.	Inorganic Check For Linearity	Glycerphosphate for % Recovery	NAP File Created	CCV	Correction Coefficient
		0	0	DI H2O						
TWS TDP	Red/Red sample	2.4	0.0744	2.0	2.5 ml of	1.8 PO4	2 ml Glycerophos.	TWS TDP (group)	1.0 mL Glycerophosphate	2.4 umoles
5 ml sample	Orn/Orn DI w/SDS	6.0	0.186	5.0	400 umole NO3 &	1.2 PO4		TWS TDP (samp. table)		PO4
15 ml persulfate	Std Cal 8.0	12.0	0.372	10.0	12 umole PO4	0.6 PO4				
					Added to 2.5 ml sample prior to digestion	0.3 PO4				
						0.12 PO4				
		0	0	DI H2O						
Low	Red/Red sample	0.6	0.0186	0.5	12 umole PO4	1.8 PO4	1ml Glycerophos.	Low TDP (group)	0.5 mL Glycerophosphate	2.4 umoles
10 ml sample	Orn/Orn DI w/SDS	2.4	0.0744	2.0		1.2 PO4		lowp (samp. table)		PO4
5 ml persulfate	Std Cal 8.0	4.8	0.1488	4.0		0.6 PO4				
						0.3 PO4				
						0.12 PO4				
		0	0	DI H2O						
Low and Salty (Above 30 ppt)	Wht/Wht sample	0.6	0.0186	0.5	12 umole PO4	3.6 PO4	1ml Glycerophos.	Low TDP (group)	0.5 mL Glycerophosphate	3.6 umoles
10 ml sample	Wht/Wht DI w/SDS	2.4	0.0744	2.0		1.8 PO4		lowp (samp. table)		PO4
5 ml persulfate	Std. Cal 8.0	4.8	0.1488	4.0		1.2 PO4				
						0.6 PO4				
						0.3 PO4				

Appendix 1. Methods and Standards Used for TDP Orthophosphat

University of Maryland Center for Environmental Science
Chesapeake Biological Laboratory
Nutrient Analytical Services
146 Williams St., Solomons, MD 20688
<http://nasl.cbl.umces.edu/>

**Standard Operating Procedure for
Determination of Dissolved Organic Carbon/Non-Purgeable Organic Carbon
(DOC/NPOC), and Total Organic Carbon (TOC) in Fresh/Estuarine/Coastal
Waters using High Temperature Combustion and Infrared Detection.**

(References: SM5310B, EPA 415.1)

Revision 2017-1
Replaces Revision 2015
Effective April 26, 2017

Revised by: _____ Date: _____

Reviewed by: _____ Date: _____

Laboratory Supervisor: _____ Date: _____

Changes affecting Revision 2015

Section 1.3: Quantitation limit quantified as 3 times the MDL and the reporting limit as the lowest standard of 0.50 mg/L C was added.

Section 1.6: Changed conforms to references and added SM5310B.

Section 2.1: added statement- The terms DOC and NPOC are used interchangeably.

Created 2 sentences: TOC and TC concentrations are derived from whole unfiltered water. NPOC concentrations are derived from water that has been filtered through a 0.7 um (nominal pore size) GF/F glass fiber filter, or equivalent.

Section 3.37: TOC 5000A deleted.

Section 3.4: Analytical Range changed to state: The instrument range is 100 ppb - 3000 ppm using a 10 - 150 µl injection volume, using regular sensitivity catalyst.

Section 3.5: Removed definition of preparation batch.

Section 5.1: Business Office Manager changed to Associate Director of Administration and Facilities Maintenance.

Section 5: Table 1: Safety Data information updated.

Section 6.3: Added language to address baking glassware and running clean check blanks.

Section 7.6: Changed Reagent KHP weight to 1.0625 g in 500 ml. Make fresh within 6 months.

Section 7.7: Changed reagent sodium bicarbonate (0.875 g) and sodium carbonate (1.1025 g) weights to reflect concentration within 250 ml. Make fresh within 4 months. Replaced H₂O with water.

Section 7.8: Added instructions to make 0.05N HCl and corrected bullet numbering.

Section 8.3: Changed wording to say “The holding time for frozen DOC samples is 28 days. It has been shown that frozen QCS samples up to a year old still fall well within the control limits, therefore if the frozen sample is stored longer than the holding time, there is minimal degradation.”

Section 8.4: Changed 4° C to ≤ 6° C.

Section 9.2.2: Added: Linear Dynamic Range (LDR) – The linear dynamic range for DOC should be established by using a blank and a minimum of five appropriate standards for the calibration curve.

Section 9.2.3: +/- 10% changed to +/- 3σ

Section 9.3.1: Nanopure water replaced with reagent water.

Section 9.3.4: Added: The Accuracy Control Chart for QCS/CRM samples is constructed from the average and standard deviation of the 20 most recent QCS/CRM measurements. The accuracy chart includes upper and lower control levels (CL=±3σ). These values are derived from stated values of the QCS/SRM. The standard deviation (σ) is specified relative to statistical confidence levels of 99% for CLs. Enter QCS/CRM results on the chart each time the sample is analyzed.

Section 9.3.5: Calibration Verification – Initial Calibration Verification (ICV) -

Immediately following the calibration curve, all standards are analyzed to confirm the calibration. Continuing Calibration Verification (CCV) - Following every 10-12 samples, one or two CCVs are analyzed to assess instrument performance. TV changed to expected value.

Section 9.5.1: Acceptance criteria changed from 0.9990 to 0.995, and r² changed to correlation coefficient.

Section 10: Corrected bullet numbering.

Section 10.1.1: Replaced Type I water with reagent water.

QC indicator table: changed correlation coefficient from 0.9990 to 0.995.

QC indicator table: changed acceptance limits of QCS, ICV, and CCV to $\pm 10\%$. Added- and at end of run bracketed within final CCVs. Also added: If the QCS value falls between $\pm 10\%$ and $\pm 20\%$, assess the blanks and standards. If QCS value is outside $\pm 20\%$ of the target value reject the run, correct the problem and rerun samples.
Section 10.1.2: Absolute value of the y intercept added to calculation of DOC.
Appendix 1 Procedures replaced with 3/29/17 revised file.
Updated Bench Sheet example.

1. SCOPE and APPLICATION

- 1.1 High temperature combustion (680°C) is used to determine dissolved organic carbon (DOC), also known as non-purgeable organic carbon (NPOC), total organic carbon (TOC), and total carbon (TC), using a non-dispersive infrared detector (NDIR). The method is used to analyze all ranges of salinity.
- 1.2 A Method Detection Limit (MDL) of 0.24 mg/L DOC was determined using the Student's *t* value (3.14, n=7) times the standard deviation of a minimum of 7 replicates. If more than seven replicates are used to determine the MDL, refer to the Student's *t* test table for the appropriate n-1 value.
- 1.3 The reporting limit for DOC is equal to the lowest standard used, which is 0.50 mg/L C. The quantitation limit is set at 3 times the MDL.
- 1.4 This procedure should be used by analysts experienced in the theory and application of organic carbon analysis. A three month training period with an analyst experienced in the analysis using the organic carbon analyzer is required.
- 1.5 This method can be used for all programs that require analysis of dissolved and total organic carbon.
- 1.6 This procedure references EPA Method 415.1 and SM5310B.

2. SUMMARY

- 2.1 The Shimadzu TOC-L uses a high temperature combustion method to analyze aqueous samples for total carbon (TC), total organic carbon (TOC) and dissolved organic carbon (DOC), also known as non-purgeable organic carbon (NPOC). The terms DOC and NPOC are used interchangeably. TOC and TC concentrations are derived from whole unfiltered water. NPOC concentrations are derived from water that has been filtered through a 0.7 um (nominal pore size) GF/F glass fiber filter, or equivalent.
- 2.2 TOC and NPOC samples are acidified and sparged with ultra pure carrier grade air to drive off inorganic carbon. TC samples are injected directly onto the catalyst bed with no pretreatment and all sources of carbon, inorganic as well as organic carbon, are measured. High temperature combustion (680°C) on a catalyst bed of platinum-coated alumina balls breaks down all carbon compounds into carbon dioxide (CO₂). The CO₂ is carried by ultra pure air to a non-dispersive infrared detector (NDIR) where CO₂ is detected.

3. DEFINITIONS

- 3.1 Acceptance Criteria – Specified limits placed on characteristics of an item, process, or service defined in a requirement document. (ASQC)
- 3.2 Accuracy – The degree of agreement between an observed value and an accepted reference value. Accuracy includes a combination of random error (precision) and systematic error (bias) components which are due to sampling and analytical operations; a data quality indicator. (QAMS)
- 3.3 Aliquot – A discrete, measured, representative portion of a sample taken for analysis. (EPA QAD Glossary)
- 3.4 Analytical Range – The instrument range is 100 ppb - 3000 ppm using a 10 - 150 µl injection volume, using regular sensitivity catalyst.
- 3.5 Batch – Environmental samples, which are prepared and /or analyzed together with the same process and personnel, using the same lot(s) of reagents. An **analytical batch** is composed of prepared environmental samples (extracts, digestates, or concentrates) and/or those samples not requiring preparation, which are analyzed together as a group using the same calibration curve or factor. An analytical batch can include samples originating from various environmental matrices and can exceed 20 samples. (NELAC/EPA)
- 3.6 Blank- A sample that has not been exposed to the analyzed sample stream in order to monitor contamination during sampling, transport, storage or analysis. The blank is subjected to the usual analytical and measurement process to establish a zero baseline or background value and is sometimes used to adjust or correct routine analytical results. (ASQC)
- 3.7 Calibrate- To determine, by measurement or comparison with a standard, the correct value of each scale reading on a meter or other device, or the correct value for each setting of a control knob. The levels of the applied calibration standard should bracket the range of planned or expected sample measurements. (NELAC)
- 3.8 Calibration – The set of operations which establish, under specified conditions, the relationship between values indicated by a measuring device. The levels of the applied calibration standard should bracket the range of planned or expected sample measurements. (NELAC)
- 3.9 Calibration Curve – The graphical relationship between known values, such as concentrations, or a series of calibration standards and their analytical response. (NELAC)
- 3.10 Calibration Method – A defined technical procedure for performing a calibration. (NELAC)
- 3.11 Calibration Standard – A substance or reference material used to calibrate an instrument. (QAMS)

- 3.11.1 Initial Calibration Standard (STD) – A series of standard solutions used to initially establish instrument calibration responses and develop calibration curves for individual target analytes.
- 3.11.2 Initial Calibration Verification (ICV) – An individual standard, analyzed initially, prior to any sample analysis, which verifies acceptability of the calibration curve or previously established calibration curve.
- 3.11.3 Continuing Calibration Verification (CCV) – An individual standard which is analyzed after every 10-15 field sample analysis.
- 3.12 Certified Reference Material (CRM) - A reference material one or more of whose property values are certified by a technically valid procedure, accompanied by or traceable to a certificate or other documentation which is issued by a certifying body. (ISO 17025)
- 3.13 Combustion tube – Quartz tube filled with platinum catalyst, heated to 680° C, into which the sample aliquot is injected.
- 3.14 Conditioning Blank – Reagent water (ASTM Type I) analyzed before the calibration curve to decrease the instrument blank and stabilize the column conditions.
- 3.15 Corrective Action – Action taken to eliminate the causes of an existing nonconformity, defect or other undesirable situation in order to prevent recurrence. (ISO 8402)
- 3.16 Deficiency – An unauthorized deviation from acceptable procedures or practices. (ASQC)
- 3.17 Demonstration of Capability – A procedure to establish the ability of the analyst to generate acceptable accuracy. (NELAC)
- 3.18 Detection Limit – The lowest concentration or amount of the target analyte that can be determined to be different from zero by a single measurement at a stated degree of confidence.
- 3.19 Duplicate Analysis – The analyses of measurements of the variable of interest performed identically on two sub samples (aliquots) of the same sample. The results from duplicate analyses are used to evaluate analytical or measurement precision but not the precision of sampling, preservation or storage internal to the laboratory. (EPA-QAD)
- 3.20 External Standard (ES) – A pure analyte (potassium hydrogen phthalate (KHP)) that is measured in an experiment separate from the experiment used to measure the analyte(s) in the sample. The signal observed for a known quantity of the pure external standard is used to calibrate the instrument response for the corresponding analyte(s). The instrument response is used to calculate the concentrations of the analyte(s) in the unknown sample.
- 3.21 Field Duplicates (FD1 and FD2) – Two separate samples collected at the same time and place under identical circumstances and treated exactly the same throughout field and laboratory procedures. Analyses of FD1 and FD2 provide a measure of the precision associated with sample

collection, preservation and storage, as well as with laboratory procedures.

- 3.22 Field Reagent Blank (FRB) – A aliquot of reagent water or other blank matrix that is placed in a sample container in the laboratory and treated as a sample in all respects, including shipment to the sampling site, exposure to the sampling site conditions, storage, preservation, and all analytical procedures. The purpose of the FRB is to determine if method analytes or other interferences are present in the field environment.
- 3.23 Furnace – Heats the combustion tube to the operating temperature of 680° C.
- 3.24 Holding time – The maximum time that samples may be held prior to analysis and still be considered valid. (40 CFR Part 136) The time elapsed from the time of sampling to the time of extraction or analysis, as appropriate.
- 3.25 Injection – The sample aliquot that is drawn into the syringe and injected into the combustion tube.
- 3.26 Instrument Detection Limit (IDL) – The minimum quantity of analyte of the concentration equivalent which gives an analyte signal equal to three times the standard deviation of the background signal at the selected wavelength, mass, retention time absorbance line, etc.
- 3.27 Laboratory Duplicates (LD1 and LD2) – Two aliquots of the same sample taken in the laboratory and analyzed separately with identical procedures. Analyses of LD1 and LD2 indicate precision associated with laboratory procedures, but not with sample collection, preservation, or storage procedures.
- 3.28 Laboratory Reagent Blank (LRB) – A matrix blank (i.e., Reagent water) that is treated exactly as a sample including exposure to all glassware, equipment, solvents, and reagents that are used with other samples. The LRB is used to determine if method analytes or other interferences are present in the laboratory environment, the reagents, or the instrument.
- 3.29 Laboratory Control Sample (LCS) – A sample matrix, free from the analytes of interest, spiked with verified known amounts of analytes from a source independent of the calibration standard or a material containing known and verified amounts of analytes. The LCS is generally used to establish intra-laboratory or analyst-specific precision and bias or to assess the performance of all or a portion of the measurement system. (NELAC)
- 3.30 Limit of Detection (LOD) – The lowest concentration level that can be determined by a single analysis and with a defined level of confidence to be statistically different from a blank, (ACS) also known as the MDL.
- 3.31 Limit of Quantitation (LOQ) – The minimum levels, concentrations, or quantities of a target variable (target analyte) that can be reported with a specified degree of confidence. The LOQ is set at 3 to 10 times the LOD, depending on the degree of confidence desired. Also known as the Quantitation Limit.

- 3.32 Linear Dynamic Range (LDR) – The absolute quantity over which the instrument response to an analyte is linear. This specification is also referred to as the Linear Calibration Range (LCR).
- 3.33 Material Safety Data Sheets (MSDS) – Written information provided by vendors concerning a chemical’s toxicity, health hazards, physical properties, fire, and reactivity data including storage, spill, and handling precautions.
- 3.34 May – Denotes permitted action, but not required action. (NELAC)
- 3.35 Method Detection Limit (MDL) – The minimum concentration of an analyte that can be identified, measured, and reported with 99% confidence that the analyte concentration is greater than zero.
- 3.36 Must – Denotes a requirement that must be met. (Random House College Dictionary)
- 3.37 Non-Dispersive Infrared Detector (NDIR) – The detector found in the Shimadzu TOC-L analyzer. Carbon dioxide is detected.
- 3.38 Precision – The degree to which a set of observations or measurements of the same property, obtained under similar conditions, conform to themselves; a data quality indicator. Precision is usually expressed as standard deviation, variance or range, in either absolute or relative terms. (NELAC)
- 3.39 Preservation – Refrigeration, freezing, and/or reagents added at the time of sample collection (or later) to maintain the chemical and or biological integrity of the sample.
- 3.40 Quality Control Sample (QCS) – A sample of analytes of known and certified concentrations. The QCS is obtained from a source external to the laboratory and different from the source of calibration standards. It is used to check laboratory performance with externally prepared test materials. Also known as CRM.
- 3.41 Run – One sample analysis from start to finish, including printout.
- 3.42 Run Cycle – Typically a day of operation – the entire analytical batch of runs from the first run to the last run.
- 3.43 Sample Volume – Amount of sample injected into the combustion tube.
- 3.44 Sensitivity – The capability of a test method or instrument to discriminate between measurement responses representing different levels (concentrations) of a variable of interest.
- 3.45 Shall – Denotes a requirement that is mandatory whenever the criterion for conformance with the specification requires that there be no deviation. (ANSI)
- 3.46 Should – Denotes a guideline or recommendation whenever noncompliance with the specification is permissible. (ANSI)
- 3.47 Sparge Time – The time required to aerate an acidified sample with ultra pure air to remove inorganic carbon to determine the concentration of organic carbon.
- 3.48 Standard Reference Material (SRM) – Material which has been certified for specific analytes by a variety of analytical techniques and/or by numerous laboratories using similar analytical techniques. These may

consist of pure chemicals, buffers, or compositional standards. The materials are used as an indication of the accuracy of a specific analytical technique. Also known as CRM.

4. INTERFERENCES

4.1 Carbonates and bicarbonates may interfere with the determination of organic carbon by increasing the concentration of CO₂ detected. These are removed by adding enough acid to the sample to bring the pH to 2 or below, then sparging with ultra-pure air for a predetermined time.

5. SAFETY



5.1 Safety precautions must be taken when handling reagents, samples and equipment in the laboratory. Protective clothing including lab coats, safety glasses and enclosed shoes should be worn. In certain situations, it will be necessary to also use gloves and/or a face shield. If solutions come in contact with eyes, flush with water continuously for 15 minutes. If solutions come in contact with skin, wash thoroughly with soap and water. Contact Solomons Rescue Squad (911) if emergency treatment is needed and also inform the Chesapeake Biological Laboratory (CBL) Associate Director of Administration and Facilities Maintenance of the incident. Contact the CBL Associate Director of Administration and Facilities Maintenance if additional treatment is required.





5.2 The toxicity or carcinogenicity of each reagent used in this procedure may not have been fully established. Each chemical should be regarded as a potential health hazard and exposure should be as low as reasonably achievable. Cautions are included for known hazardous materials and procedures.

5.3 Do not wear jewelry when troubleshooting electrical components. Even low voltage points are dangerous and can injure if allowed to short circuit.

5.4 The following hazard classifications are listed for the chemicals used in this procedure. Detailed information is provided on Material Safety Data Sheets (MSDS).

Table 1:

Chemical	Health Hazard	Fire Hazard	Instability Hazard	Specific Hazard	
Potassium Hydrogen Phthalate	1	1	0	Irritant	
Sodium Carbonate, Anhydrous	2	0	1	Irritant	
Sodium Bicarbonate	1	0	0		

Hydrochloric Acid	3	0	2	ACID, COR	
Sodium Hydroxide	3	0	1	ALK, COR	
Platinum Catalyst on Alumina Beads	1	0	0		
Soda Lime	3	0	0	COR	
Sulfuric Acid	4	0	2	ACID, COR	

On a scale of 0 to 4 the substance is rated on four hazard categories: health, flammability, reactivity, and contact. (0 is non-hazardous and 4 is extremely hazardous)

HAZARD RATING

Health Hazard - Blue: 4 – deadly, 3 – extreme danger, 2 – hazardous, 1 – slightly hazardous, 0 – normal material

Fire Hazard - Red: Flash Points: 4 – below 73° F, 3 – below 100° F, 2 – below 200° F, 1 – above 200° F, 0 – will not burn

Instability Hazard - Yellow: 4 – may detonate, 3 – Shock and heat may detonate, 2 – violent chemical change, 1 – unstable is heated, 0 - stable

Specific Hazard - White: Acid = ACID, Alkali = ALK, Corrosive = COR, Oxidizer = OXY

6. EQUIPMENT AND SUPPLIES

6.1 A Total Organic Carbon Analyzer capable of maintaining a combustion temperature of 680° C and analyzing for organic and inorganic carbon. The Shimadzu TOC-L is used in this laboratory.

6.2 Freezer, capable of maintaining $-20 \pm 5^{\circ} \text{C}$.

6.3 Lab ware – All reusable lab ware (glass, Teflon, plastic, etc) should be sufficiently clean for the task objectives. This laboratory soaks all lab ware related to this method in a 10% HCl (v/v) acid bath overnight, and the lab ware is rinsed copiously with ASTM Type I water, as well as bakes the glassware at 400° C for at least 1 hour and runs clean check blanks with every run.

7. REAGENTS AND STANDARDS

7.1 Purity of Water – Unless otherwise indicated, references to water shall be understood to mean reagent water conforming to ASTM Specification D

1193, Type I. Freshly prepared water should be used for making the standards intended for calibration. The detection limits of this method will be limited by the purity of the water and reagents used to make the standards.

- 7.2 Purity of Reagents – Reagent grade chemicals shall be used in all tests. Unless otherwise indicated, it is intended that all reagents shall conform to specifications of the Committee on Analytical Reagents of the American Chemical Society, where such specifications are available. Other grades may be used, provided it is first ascertained that the reagent is of sufficiently high purity to permit its use without compromising the accuracy of the determination.
- 7.3 Potassium Hydrogen Phthalate (KHP) $C_6H_4(COOK)(COOH)$ – primary standard for organic carbon.
- 7.4 Sodium Hydrogen Carbonate ($NaHCO_3$) and Sodium Carbonate (Na_2CO_3) – primary standard for inorganic carbon; may also be used to determine sparging efficiency for the NPOC method.

- 7.5 Sulfuric Acid, 9 N –
- | | |
|--|---------|
| Sulfuric acid (H_2SO_4), concentrated, | 250 ml |
| Reagent water, q.s. | 1000 ml |

In a 1000 ml volumetric flask, add 250 ml of concentrated sulfuric acid to ~600 ml of reagent water. Dilute to 1000 ml with reagent water. Allow solution to cool to near room temperature before filling completely to the graduated mark on the flask

- 7.6 Organic Carbon Stock Standard: Potassium Hydrogen Phthalate (KHP) Standard, 1000 mg/l
- | | |
|--|----------|
| Potassium hydrogen phthalate ($HOCOC_6H_4COOK$), | |
| Dried at 45° C, min. 1 hour | 1.0625 g |
| Reagent water | 500 ml |

In a 500 ml volumetric flask, dissolve 1.0625 g of potassium hydrogen phthalate in ~300 ml of reagent water. Dilute to 500 ml with reagent water. Make fresh within 6 months. Store at 4° C.

- 7.7 Inorganic Carbon Stock Standard: Sodium Hydrogen Carbonate/ Sodium Carbonate ($NaHCO_3/Na_2CO_3$) Standard, 1000 mg/l
- | | |
|--|----------|
| Sodium Hydrogen Carbonate ($NaHCO_3$) | 0.875 g |
| Sodium Carbonate, Anhydrous (Na_2CO_3) | 1.1025 g |
| Reagent water | 250 ml |

In a 250 ml volumetric flask, dissolve 0.875 g $NaHCO_3$ and 1.1025 g Na_2CO_3 in ~150 ml reagent water. Dilute to 250 ml with reagent water. Make fresh within 4 months. Store at 4° C.

7.8 Hydrochloric Acid, 0.5 N –	
Hydrochloric Acid, 1 N	1.0 ml
Reagent water	40.0 ml

Combine 40.0 ml reagent water with 1.0 ml 1 N HCl in any appropriate storage container. This solution is used in the Type B Halogen scrubber. Make fresh as needed.

7.9 Blanks – ASTM D1193, Type I water is used for the Laboratory Reagent Blank.

7.10 Quality Control Sample (QCS) – For this procedure, the QCS can be any certified dissolved sample which is obtained from an external source. If a certified sample is not available, then use the standard material (KHP).

8 SAMPLE COLLECTION, PRESERVATION, AND STORAGE

8.1 Water collected for DOC should be filtered through a Whatman GF/F glass fiber filter (nominal pore size 0.7 μm), or equivalent.

8.2 Water collected for DOC should be frozen at $\leq -20^\circ\text{C}$, or acidified with 9N H_2SO_4 to a pH of ≤ 2 . The sample container should be either borosilicate glass or Teflon. Plastic containers may be used if well cleaned and aged. Freshwater samples should be frozen in Teflon or plastic to prevent breakage.

8.3 The holding time for frozen DOC samples is 28 days. It has been shown that frozen QCS samples up to a year old still fall well within the control limits, therefore if the frozen sample is stored longer than the holding time, there is minimal degradation.

8.4 Acidified DOC samples may be frozen, as above, or refrigerated at $\leq 6^\circ\text{C}$ for no longer than 28 days.

9 QUALITY CONTROL

9.1 The laboratory is required to operate a formal quality control (QC) program. The minimum requirements of this program consist of an initial demonstration of laboratory capability and the continued analysis of laboratory instrument blanks and calibration standard material, analyzed as samples, as a continuing check on performance. The laboratory is required to maintain performance records that define the quality of data generated.

9.2 Initial Demonstration of Capability

9.2.1 The initial demonstration of capability (iDOC) – is used to characterize instrument performance (MDLs) and

laboratory performance (analysis of QC samples) prior to the analyses conducted by this procedure.

- 9.2.2 Linear Dynamic Range (LDR) – The linear dynamic range for DOC should be established by using a blank and a minimum of five appropriate standards for the calibration curve.
- 9.2.3 Quality Control Sample (QCS/SRM) – When using this procedure, a quality control sample is required to be analyzed at the beginning and end of the run, to verify data quality and acceptable instrument performance. If the determined concentrations are not within $\pm 3\sigma$ of the certified values, performance of the determinative step of the method is unacceptable. The source of the problem must be identified and corrected before either proceeding with the initial determination of MDLs or continuing with analyses.
- 9.2.4 Method Detection Limits (MDLs) – MDLs should be established for DOC/NPOC using a low level ambient water sample. To determine the MDL values, analyze a minimum of seven replicate aliquots of water. Perform all calculations defined in the procedure (Section 10) and report the concentration values in the appropriate units. Calculate the MDL as follows:

$$\text{MDL} = S t_{(n-1, 1-\alpha=0.99)}$$

Where, $t_{(n-1, 1-\alpha=0.99)}$ = Student's t value for the 99% confidence level with $n-1$ degrees of freedom ($t = 3.14$ for 7 replicates)

n = number of replicates

S = Standard Deviation of the

replicate analyses.

- 9.2.5 MDLs should be determined yearly or more frequently whenever there is a significant change in the instrument response or configuration.

9.3 Assessing Laboratory Performance

- 9.3.1 Laboratory Reagent Blank (LRB) – The laboratory must analyze at least one LRB with each batch of samples. The LRB consists of reagent water treated the same as the samples. LRB data are used to assess contamination from the laboratory environment.
- 9.3.2 Quality Control Sample (QCS)/ Certified Reference Material (CRM) – When using this procedure, a quality control sample is required to be analyzed at the beginning of the run and end of the run, to verify data quality and

acceptable instrument performance. If the determined concentrations are not within $\pm 3\sigma$ of the certified values, performance of the determinative step of the method is unacceptable. The source of the problem must be identified and corrected before either proceeding with the initial determination of MDLs or continuing with the analyses. The results of these samples shall be used to determine batch acceptance.

- 9.3.3 The QCS will be obtained from a source external to the laboratory and different from the source of calibration standards.
- 9.3.4 Control Charts – The CRM data are tracked, and the slope, y-intercept, and correlation coefficient data are compiled and tracked.
- The CRM concentrations should fall within $\pm 3\sigma$ of the expected value. The Accuracy Control Chart for QCS/CRM samples is constructed from the average and standard deviation of the 20 most recent QCS/CRM measurements. The accuracy chart includes upper and lower control levels ($CL=\pm 3\sigma$). These values are derived from stated values of the QCS/SRM. The standard deviation (σ) is specified relative to statistical confidence levels of 99% for CLs. Enter QCS/CRM results on the chart each time the sample is analyzed
- 9.3.5 Calibration Verification – Initial Calibration Verification (ICV) - Immediately following the calibration curve, all standards are analyzed to confirm the calibration. Continuing Calibration Verification (CCV) - Following every 10-12 samples, one or two CCVs are analyzed to assess instrument performance. The CCVs are made from the same material as calibration standards (KHP), and are to be within $\pm 3\sigma$ of the expected value. Failure to meet the criteria constitutes correcting the problem and reanalyzing the samples. If not enough sample exists, the data must be qualified if reported.

9.4 Assessing Analyte Recovery

- 9.4.1 Matrix spikes are performed on a 20% QA/QC basis.
- 9.4.2 1.0 ml of the highest KHP standard in the curve is added to 10.0 ml of sample for a total volume of 11.0 ml.
- 9.4.3 1.0 ml standard $1.0/11.0 = 0.09$
- 9.4.4 0.09 X STD conc.
- 9.4.5 10.0 ml sample $10.0/11.0 = 0.91$
- 9.4.6 (original sample conc. X 0.91) + (0.09 x std conc.) =
(expected conc.) mg/L

9.4.7 Percent Recovery for each spiked sample should fall within 80-120%. Where:

$$\%SR = (\text{Actual/Expected}) \times 100$$

9.4.8 Relative Percent Difference (RPD) of duplicated samples should be less than 20%. Where:

$$RPD = \frac{\text{difference of duplicates}}{\text{Average of duplicates}} \times 100$$

Assess whether the analytical result for the CRM/QCS sample confirms the calibration when calculated as follows

$$\% \text{ Recovery} = \text{AMC/CRM} \times 100$$

Where:

AMC = Average measured concentration of the CRM sample

CRM = Certified value of the CRM

The analytical result must fall with the range of 80-120%

9.5 Data Assessment and Acceptance Criteria for Quality Control Measures

9.5.1 The Acceptance Criteria for DOC is 0.995. If the correlation coefficient is less than acceptable, all blanks and standards analyzed during the run may be averaged into the curve.

9.6 Corrective Actions for Out of Control Data

9.6.1 If the acceptance criteria are still not met, the samples are to be reanalyzed.

Table 2:

QC Indicator	Acceptance/ Action Limits	Action	Frequency (Batch)
Correlation Coefficient	≥ 0.995	If <0.995 , evaluate data points of the calibration curve. If any data point is outside established limits, reject as outlier.	1 per batch if acceptable.
Quality Control Sample (QCS)/ Certified Reference Material (CRM)	$\pm 10\%$	If the QCS value falls between $\pm 10\%$ and $\pm 20\%$, assess the blanks and standards. If QCS value is outside $\pm 20\%$ of the target value reject the run, correct the problem and rerun samples.	Beginning of run following the ICV and at end of run bracketed within final CCVs.

Initial Calibration Verification (ICV)	$\pm 10\%$	Recalibrate if outside acceptance limits.	Beginning of run following standard curve.
Continuing Calibration Verification (CCV)	$\pm 10\%$	If outside 10%, correct the problem. Rerun all samples following the last in-control CCV.	After every 10-12 samples and at end of batch.
Method Blank/Laboratory Reagent Blank (LRB)	\leq Method Quantitation Limit	If the LRB exceeds the quantitation limit, results are suspect. Rerun the LRB. If the concentration still exceeds the quantitation limit, reject or qualify the data, or raise the quantitation limit.	Following the ICV, after every 10-12 samples following the CCV and at the end of the run.
Method Quantitation Limit (MQL): The concentration of the lowest standard.		When the value is outside the predetermined limit and the ICV is acceptable, reanalyze the sample. If the reanalysis is unacceptable, increase the concentration and reanalyze. If this higher concentration meets the acceptance criteria, raise the reporting limit for the batch.	Beginning of run following the LRB.
Laboratory Fortified Sample Matrix Spike	$\pm 20\%$	If the recovery of any analyte falls outside the designated acceptance limits and the QCS is in control, the recovery problem is judged matrix induced. Repeat the LFM and if the sample results are again outside the acceptable recovery range, the sample should be reported with a "matrix induced bias" qualifier.	1/20
Laboratory Duplicate	$\pm 20\%$	If the RPD fails to meet the acceptance limits, the samples should be reanalyzed. If the RPD again fails to meet the acceptance limits, the sample must be reported with a qualifier identifying the sample analysis result as not having acceptable RPD for duplicate analysis.	1/10 recommended 1/20 accepted

10 CALIBRATION AND STANDARDIZATION

10.1 Calibration – Daily calibration must be performed before sample analysis may begin.

10.1.1 Reagent water is used as the “zero point” in the calibration. The standards are calculated by the following equation:

$$\text{mg DOC/L} = (A_{\text{STD}}) / m$$

Where: A_{STD} = Area of the standard
 m = slope of the regression line

10.1.2 DOC sample concentration is calculated using the following equation:

$$\text{mg DOC/L} = (A_{\text{S}} - \|y\|) / m$$

Where: A_{S} = area of the sample
 $\|y\|$ = absolute value of the y intercept
 m = slope of the regression line

11. References:

- 11.1 EPA Method 415.1. Determination of Total Organic Carbon in Water using Combustion or Oxidation.
- 11.2 Standard Methods for the Examination of Water and Wastewater. Approval date 2000. Method 5310B: High Temperature Combustion Method.
- 11.3 Sugimura, Y. and Y. Suzuki. 1988. A high temperature catalytic oxidation method for the determination of non-volatile dissolved organic carbon in seawater by direct injection of a liquid sample. Mar. Chem. 24:105-131.

Appendix I

PROCEDURE

Daily Operations

Make sure the 2nd stage of the regulator on the air tank (Air Gas Ultra Zero Grade Air, size A) is set at no higher than 30 psi. Replace the tank when the tank pressure falls below 500 psi.

To turn on instrument, push the on/off switch on right side of instrument to on, and then push button located on front of instrument. The front indicator light will cycle through the colors ending with orange, which means the instrument is in a not-ready state. The indicator light turns green when the instrument is up to temperature and all parameters are OK. The light will be blue while the instrument is running samples. If the indicator light is red, refer to the software and the manual to determine the problem. If necessary, call Shimadzu (1-800-477-1227) for tech support.

Open software by clicking on the TOC-L sample table icon. There is no password. Just hit enter when password screen appears.

Open a new sample table by clicking on NEW in the toolbar. Click OK. Then hit CONNECT located in the tool bar. A sample table must be open to connect the instrument. The furnace automatically turns on.

At this time, refill the dilution, reagent blank, and rinse water bottles. The reagent blank water is in the 500 ml Teflon bottle or brown glass TOC reagent water bottle beside the instrument. The rinse water bottle is located behind the autosampler. The dilution bottle is located on the left side of the instrument along with the 9 N H₂SO₄ bottle, 1 N HCl bottle, and the drain bottle. Sulfuric acid is used in the NPOC analysis, and the HCl is used in the TIC analysis. Check the volume of the acid bottle in use, and the drain bottle. The liquid level of the drain bottle should be just below the arm. 250 mls of 9 N H₂SO₄ or 1 N HCl is plenty for several weeks of analysis. Unless the dilution water is being used in serial dilutions of the standard curve, it is not necessary to change daily. Replace weekly regardless.

Open the front door of the instrument and check the liquid level of the humidifier located on the right hand side. The level should be between the high and low marks. Add reagent water as needed by removing cap at top.

Check the level of liquid in the Type B Halogen Scrubber (the long tube next to the syringe which contains the rolled stainless mesh). Add 0.05 N HCl (40 ml reagent H₂O + 1 ml 1N HCl) so that the level is an inch or so above the level of the mesh screen. There is a small drain line attached to the 8-port valve at port 6 which is frequently pulled out of

the drain when removing the cap of the Type B Halogen Scrubber. When recapping the scrubber, ALWAYS check that the small tubing from port 6 on the 8 port valve is in the black capped drain port behind the scrubber. Replace the 0.05 N HCl each time the column is changed.

It is recommended that these next two steps should be performed before each run. An explanation of the Maintenance Menus can be found in the User's Manual, Chapter 7.6 p.302-308.

Before running blanks or beginning a sample run, from the program, select Instrument and Maintenance. Click on Residue Removal, then click start. Close when finished.

Next, under Instrument Maintenance, select Replace Flowline Content, and then click start. Close when finished.

If the instrument has been sitting unused, or if several runs of high salt samples have been analyzed, perform a TC Regeneration. Again, under Instrument Maintenance, select Regeneration of TC Catalyst, and then click start. This takes several minutes. Close when finished.

Loading samples: Read Section in Full before proceeding.

The volume of the sample vial is 24 mls. The volume of the Teflon bottles is 30 mls, which means, in most cases, the analysis is volume limited. Fill the sample vial between half and $\frac{3}{4}$ full. The absolute minimum volume to use in the sample vial is 10 mls. Choose a sample with maximum volume in the Teflon bottle ahead of time to be the QA sample for duplicates or to make a spike. Cover each sample vial with a septum (or foil square if not available) and secure with an open septum cap.

Standard Curve:

The reagent blank water is in the bottle beside the instrument. This bottle is considered Position 0 on the sample wheel.

Load the other standards in the curve in the first several slots of the wheel.

QA/QC

Analyze a certified reference control sample (CRM) at least 3-4 times during the run. With each batch of control samples, a method is created in the control sample folder. To insert a control sample, highlight the line in the sample table. Click on INSERT on the tool bar, and then click on Control Sample. Once the folder is open, click on the appropriate file. The control CRM will be inserted above the highlighted line.

Analyze a blank, the lowest standard, and a CRM (or a mid-range standard) every 10-12 samples. The CRM's are frozen in 30-ml or 60-ml bottles. Fill 2 sample vials if analyzing more than 20 samples. Fill a 24 ml sample vial to the shoulder with CRM, cover with septum and cap. There is enough volume to sample the vial twice. When inserting the control sample in the sample table, assign the same vial position for each time. The autosampler is capable of returning to a particular vial site.

For the sample chosen to duplicate, fill the vial to the shoulder and cover. Indicate on the bench sheet at the appropriate location that the duplicate is to be inserted at that spot. If sample volume is not an issue, two sample vials can be used instead.

For the sample chosen to be spiked, withdraw 10.0 mls of sample using a volumetric pipet and add it to a sample vial. Then add 1.0 ml of the highest standard of the standard curve to the vial. Cover and cap, then gently shake to mix. Put the spiked sample in the proper location in the sample wheel. With the leftover sample, pour into another sample vial as the original sample. There is usually not enough volume to sample rinse the vial used for the spike or original sample.

Alternate duplicates and spikes every 10-12 samples.

End the run with blanks and standards, with the last control sample inserted between the bracketing standards.

Sample Table:

To create a new calibration file, refer to the User's Manual, Chapter 4.1 pp. 89-93, and follow the Calibration Curve Wizard Setup. Several curve templates are set up and are overwritten with new curve data each time they are used.

Create a method by clicking on File/New/Method and follow the Method Wizard Setup. Refer to the User's Manual Chapter 4.1 pp.94-96. A new method is created with each run.

Use drop down box to select type of analysis (i.e.: NPOC). Leave default Sample Name and Default Sample ID empty.

Enter the file name, and then click Next. (Example: dnr st martins041213)

The calibration curve is chosen on the next screen. Click Next again. Confirm the injection parameters to match the calibration curve. Confirm that Multiple Injections is checked. Click Next again.

Use default settings on the next page, and None for Pharmaceutical water testing on the last page.

Click Finish. The method is complete.

Editing the Sample Table:

Highlight the first line of the sample table to insert information. From the toolbar at the top, click on Insert.

Insert 3-4 conditioning blanks by clicking on Multiple Samples. Follow the wizard prompts. The water for conditioning blanks is the same as the reagent water in position 0.

Highlight the next available line to insert the calibration curve. Click on Insert/calibration curve. Choose the proper calibration file.

Highlight the next available line to insert multiple samples. Follow the wizard prompts. Leave the Sample Name and Sample ID blank.

Once the sample table has been set up, enter the sample names and IDs.

It is easiest to insert Control samples after the sample names and IDs are in place. Highlight the line below where the control sample is to be inserted. Click on Insert and select Control Sample. Choose the proper file.

When all sample and control information is entered into the table, enter the vial position numbers. Click on the carousel icon (looks like a birthday cake) in the sample table toolbar. The vial positions correspond to the numbered positions on the bench sheet. Be sure duplicate samples are numbered to match the original if sampling from the same vial. Click OK when finished.

Proof all entries and save the sample table. Click File/Save As to name the file.

Example: 2013_05_09_dnr st martins 042213

Highlight the first line of the sample table.

Click START. The Measurement Start Window is displayed. Click on the procedure to be performed when the analysis is complete. The instrument is kept running except over weekends. If no samples are to be run the next day, select Keep Running in case samples go off scale and need to be rerun. They can be inserted at the end of the sample table and run. Insert sample information and vial positions, then SAVE the file.

To open the Sample Window, click on the graph icon on the sample table to view peak information.

Accessing the data:

When the run has finished:

To save the file to another source (i.e. the shared network drive), (TOC-L-1) click File/Save As. TOC-L-2 does not communicate with the shared network drive in this capacity. With TOC-L-2, to save the standard curve, highlight the standard curve in the sample table. Select Print: Print highlighted. Print to XPS file. Name file as a curve file. The file is saved to the shared network drive. Open the file in the XPS Viewer. Print to printer and save to the desktop.

To export data, click File/ASCII Export. Save the file in each form, Normal and Detailed. The Normal file contains only concentration information. The Detailed file includes all injection data. The ASCII files can now be opened in Excel. This works with both instruments.

Open TOC-L Sample Table on the desktop. Open the file from the shared network drive. Save the file to the desktop using the same file name.

To print the calibration curve information, highlight the calibration curve line in the sample table. Select Print on the toolbar, and Highlighted.

Below is an example of the TOC bench sheet.

SHIMADZU TOC-L DATA SHEET			Column Run Counter			
TODAYS DATE:		TOC-L 1 2	CRUISE :			
ANALYST: NLK OTHER:						
FILE NAME:						
SPIKE CONC.: 10 mg/L...20 mg/L			INJECTION VOLUME: 50 uL		WORKING STDS MADE:	
VIAL#	SAMPLE ID		VIAL#	SAMPLE ID	VIAL#	SAMPLE ID
0	DHOH		31		62	
1			32		63	
2			33		64	
3			34		65	
4			35		66	
5			36		67	
6			37		68	
7			38		69	
8			39		70	
9			40		71	
10			41		72	
11			42		73	
12			43		74	
13			44		75	
14			45		76	
15			46		77	
16			47		78	
17			48		79	
18			49		80	
19			50		81	
20			51		82	
21			52		83	
22			53		84	
23			54		85	
24			55		Pre Run Checks	
25			56		Mark All That Apply	
26			57		Residue Removal (Daily) []	
27			58		Flowline Wash (Daily) []	
28			59		Regenerate Catalyst (as needed) []	
29			60		New Column (as needed) []	
30			61			

UNIVERSITY OF MARYLAND CENTER FOR ENVIRONMENTAL SCIENCE
CHESAPEAKE BIOLOGICAL LABORATORY
NUTRIENT ANALYTICAL SERVICES LABORATORY
146 Williams St., Solomons MD 20688
<http://nasl.cbl.umces.edu/>

**Standard Operating Procedure for Determination of Carbon and Nitrogen in
Particulates and Sediments of Fresh/Estuarine/Coastal Waters, Plant and Animal
Tissue, and Soils Using Elemental Analysis.**

(Reference Method: EPA 440.0)

**Revision 2017-1.
Replaces revision 2015.
Effective April 26, 2017**

Revised by: _____ Date: _____

Reviewed by: _____ Date: _____

Laboratory Supervisor: _____ Date: _____

Revisions 2017

Section 1.3: Changed the quantitation limits to current values (3xMDL) for C and N

Section 3: Removed definitions that were not applicable.

Section 3.4: Updated the definition of “batch” to match our actual process.

Section 3.10.2: Added details to definition of ICV: K value calculations against the mean are sufficient to confirm the calibration is good.

Section 3.10.3: Changed frequency of CCV from every 20-23 samples to every 25 samples; added details on what types of CCV samples can be used.

Section 3.20: Edited the definition to be more concise.

Sections 3.53 & 3.66: Updated definitions to include CRM reference.

Section 5.1: Updated the CBL contact person for incident reports, etc.

Section 5.7: Updated Table 1.

Section 6.1: Changed combustion temperature from 975°C to 980°C.

Section 7.4: Changed LFB for all samples to a capsule and sleeve with a weighed amount of standard; removed details regarding aqueous samples and filter pads with weighed amount of standard as this is not a current practice; added details about recalculation if needed. Replaced the word acetanilide with atropine; it is the secondary source for quality control checks against the calibration standard.

Section 7.5: Added laboratory fortified blank to the list of acceptable quality control samples.

Section 8.1: Added samples need to be filtered within 24 hours.

Section 9.1: Removed the word “calibration” from “calibration standards analyzed” in reference to quality control program; different standards are used throughout the run to monitor quality.

Section 9.2.2: Changed frequency QCS are run; updated acceptance criteria.

Section 9.2.3: Added sub-section describing MDL determination; updated source of water sample.

Section 9.2.4: Removed text referring to sample concentrations that are three to five times higher than the estimated MDL; this is no longer applicable to MDL determination. Updated when new MDL's should be determined.

Section 9.3.1: Corrected reference to LRB from section 3.40 to section 3.37; changed sediment LRB values for nitrogen from 50 to 15 μ v; changed aqueous LRB values from 375 to 300 μ v (carbon) and 50 to 15 μ v (nitrogen); updated control chart details.

Section 9.3.2: Corrected when QCS/SRM samples are run. Merged section 9.3.3 into section 9.3.2 as both sections referred to the same information. Updated control chart details.

Section 9.5: Updated Table 3 with new criteria and different blank values; updated RPD acceptance limits to match those of the Chesapeake Bay Program.

Section 9.7.1: Changed details for running an unknown standard from every twenty runs to every 25 samples; the previous language was incorrect.

Section 10.5-10.7: Edited language for clarification.

Section 10.6: Combined section 10.6.1 with 10.6.

Section 10.7: Updated with details on checking K value acceptance limits; updated language to incorporate the option to run the standard as an unknown (atropine already serves as a secondary check).

Section 11.2.2: Changed sample tray set-up in Table 4 to reflect current operating procedures. There is now a conditioner at number 1 instead of a blank sample and Atropine is weighed then placed directly into a capsule not weighed onto a blank filter pad. QCS/SRM has also been added.

Section 12: Corrected section numbering.

Section 12.1: Added details on processing raw results by exporting data directly from the instrument computer.

Section 12.3: Updated example of Excel spreadsheet and cell descriptions.

Section 13: Removed information on Method Performance and adjusted section numbering.

1. SCOPE and APPLICATION

- 1.1. Elemental analysis is used to determine particulate carbon (PC), and particulate nitrogen (PN) in fresh, estuarine and coastal waters and sediments as well as for plant and animal tissue and soils. The method measures the PC and PN irrespective of source (organic or inorganic.)
- 1.2. A Method Detection Limit (MDL) of 0.0633 mg C/l and 0.0105 mg N/l, for filtered samples, and 0.130 %C and 0.008% N for sediment samples, were determined using the Student's *t* value (3.143) times the standard deviation of seven replicates. If more than seven replicates are used to determine the MDL, refer to the Student's *t* test table for the appropriate n-1 value.
- 1.3. The quantitation limit was set at 0.1899 mg C /L and 0.0315 mg N/l, or three times the method detection limit.
- 1.4. This procedure should be used by analysts experienced in the theory and application of elemental analysis. A minimum of 3 months experience with an elemental analyzer is recommended.
- 1.5. This method is for use by all programs that require analysis of particulate carbon and nitrogen in water and sediment, soils and tissues. The need to determine the organic fraction of the total particulate carbon and nitrogen in samples depends on the data-quality objectives of the study. Section 11.2.5 outlines the procedure used to ascertain the organic fraction.

2. SUMMARY

- 2.1. In the Exeter Analytical, Inc. Model CE-440 Elemental Analyzer, the carbon and nitrogen content in organic and inorganic compounds can be determined. Combustion of the sample occurs in pure oxygen under static conditions. The combustion train and analytical system are shown below in the CE-440 flow diagram. Helium is used to carry the combustion products through the analytical system to atmosphere, as well as for purging the instrument. Helium was selected for this purpose because it is chemically inert relative to tube packing chemicals, and it has a very high coefficient of thermal conductivity. The products of combustion are passed over suitable reagents in the combustion tube to assure complete oxidation and removal of undesirable by-products such as sulfur, phosphorus and halogen gases. In the reduction tube, oxides of nitrogen are converted to molecular nitrogen and residual oxygen is removed. In the mixing volume the sample gasses are thoroughly homogenized at precise volume, temperature, and pressure. This mixture is released through the sample volume into the thermal conductivity detector. Between the first of three pairs of thermal conductivity cells an absorption trap removes water from the sample gas. The differential signal read before and after the trap reflects the water concentration and, therefore, the amount of hydrogen in the original sample. A similar measurement is made of the signal output of a second pair of thermal conductivity cells, between which a trap removes carbon dioxide, thus determining the carbon content. The remaining gas now consists only of helium and nitrogen. This gas passes through a thermal conductivity cell and the output signal is compared to a

reference cell through which pure helium flows. This gives the nitrogen concentration.

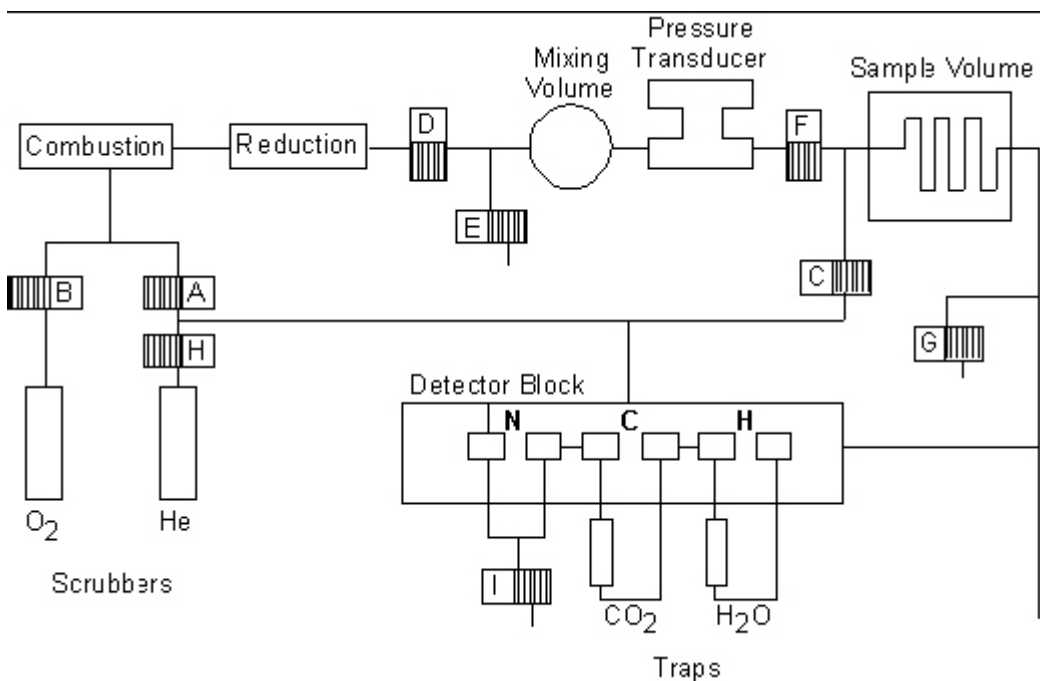

FIGURE 1. Schematic diagram of the Exeter Analytical, Inc. CE-440 Elemental Analyzer

3. DEFINITIONS

- 3.1. **Acceptance Criteria** - Specified limits placed on characteristics of an item, process, or service defined in a requirement document. (ASQC)
- 3.2. **Accuracy** - The degree of agreement between an observed value and an accepted reference value. Accuracy includes a combination of random error (precision) and systematic error (bias) components which are due to sampling and analytical operations; a data quality indicator. (QAMS)
- 3.3. **Aliquot** - A discrete, measured, representative portion of a sample taken for analysis. (EPA QAD Glossary)
- 3.4. **Batch** - Environmental samples, which are prepared and/or analyzed together as a group using the same calibration curve or factor with the same process and personnel using the same lot(s) of reagents. An analytical batch is composed of approximately 50 environmental samples meeting the above mentioned criteria and with a maximum time between the start of processing of the first and last sample in the batch to be 6-10 hours. An analytical batch defined by NELAC can include samples originating from various environmental matrices and can exceed 20 samples. (NELAC/EPA)

- 3.5. **Blank** - A sample that has not been exposed to the analyzed sample stream in order to monitor contamination during sampling, transport, storage or analysis. The blank is subjected to the usual analytical and measurement process to establish a zero baseline or background value and is sometimes used to adjust or correct routine analytical results. (ASQC)
 - 3.5.1. **Blank value** = blank read minus blank zero. An indicator of the stability of the system. (Exeter)
- 3.6. **Bridge** - Electrical configuration of the thermal conductivity filaments.(Exeter)
- 3.7. **Calibrate** - To determine, by measurement or comparison with a standard, the correct value of each scale reading on a meter or other device, or the correct value for each setting of a control knob. The levels of the applied calibration standard should bracket the range of planned or expected sample measurements. (NELAC)
- 3.8. **Calibration** - The set of operations which establish, under specified conditions, the relationship between values indicated by a measuring device. The levels of the applied calibration standard should bracket the range of planned or expected sample measurements. (NELAC)
- 3.9. **Calibration Method** - A defined technical procedure for performing a calibration. (NELAC)
- 3.10. **Calibration Standard** - A substance or reference material used to calibrate an instrument. (QAMS)
 - 3.10.1. **Initial Calibration Standard (CAL)** - An accurately weighed amount of a certified chemical used to calibrate the instrument response with respect to analyte mass. For this procedure the calibration standard is acetanilide, 99.9%+ purity. It has known percentages of C, H, and N.
 - 3.10.2. **Initial Calibration Verification (ICV)** - An individual standard, analyzed initially, prior to any sample analysis, which verifies acceptability of the calibration curve or previously established calibration curve. To verify that the instrument is running well, all the individual K-Factor values should be within +/- 0.08 of the mean. This may be a substitute for the ICV.
 - 3.10.3. **Continuing Calibration Verification (CCV)** - An individual standard which is analyzed after 25 samples and at the end of the analysis run cycle. This standard may be a certified reference material or internal standard such as Atropine.
- 3.11. **Capsule** - Aluminum container. Used for containing samples and standards with an accurate weight and maintains integrity prior to combustion.
- 3.12. **Certified Reference Material** - A reference material one or more of whose property values are certified by a technically valid procedure, accompanied by or traceable to a certificate or other documentation which is issued by a certifying body. (ISO 17025)
- 3.13. **Combustion Time** - Time for sample to fully combust in an oxygen environment.
- 3.14. **Combustion Tube** - Quartz tube packed with reagents and used for sample combustion.
- 3.15. **Conditioner** - A standard chemical which is not necessarily accurately weighed that is used to coat the surfaces of the instrument with the analytes (water vapor, carbon dioxide, and nitrogen).

- 3.16. **Corrective Action** - Action taken to eliminate the causes of an existing nonconformity, defect or other undesirable situation in order to prevent recurrence. (ISO 8402)
- 3.17. **Deficiency** - An unauthorized deviation from acceptable procedures or practices. (ASQC)
- 3.18. **Demonstration of Capability** - A procedure to establish the ability of the analyst to generate acceptable accuracy. (NELAC)
- 3.19. **Detection Limit** - The lowest concentration or amount of the target analyte that can be determined to be different from zero by a single measurement at a stated degree of confidence.
- 3.20. **Detector** - Consists of three bridges and determines the percentages of carbon, hydrogen, and nitrogen in the sample via thermal conductivity.
- 3.21. **Detector Oven** - Keeps the temperature of the detector, pressure transducer, mixing volume, and sample volume constant.
- 3.22. **Double Drop** - Two samples are dropped for one run - used for filter and inorganic applications. Sample requires a + prefix.
- 3.23. **External Standard (ES)** - A pure analyte (atropine) that is measured in an experiment separate from the experiment used to measure the analyte(s) in the sample. The signal observed for a known quantity of the pure external standard is used to calibrate the instrument response for the corresponding analyte(s). The instrument response is used to calculate the concentrations of the analyte(s) in the unknown sample.
- 3.24. **Field Duplicates (FD1 and FD2)** - Two separate samples collected at the same time and place under identical circumstances and treated exactly the same throughout field and laboratory procedures. Analyses of FD1 and FD2 give a measure of the precision associated with sample collection, preservation and storage, as well as with laboratory procedures.
- 3.25. **Fill Time** - Time required to build-up the pressure in the mixing volume to 1500 mm Hg.
- 3.26. **Filtered Sample** - An accurately measured amount of water from fresh, estuarine or coastal samples, concentrated on a filter pad by filtering through a 25 mm Whatman GF/F filter or equivalent, which has been pre-combusted at 500° C for 90 minutes.
- 3.27. **Furnace** - Heats the reduction and combustion tubes to operating temperature.
- 3.28. **Heated Line** - Connects the reduction tube outlet to the inlet of the mixing volume. Heated to prevent condensation of gases on tube walls.
- 3.29. **Holding Time** - The maximum time which samples may be held prior to analysis and still be considered valid. (40 CFR Part 136) The time elapsed from the time of sampling to the time of extraction or analysis, as appropriate.
- 3.30. **Inject Solenoid** - Solenoid used on the automated injection system to actuate the rotation of the sample wheel.
- 3.31. **Injection** - Moving the ladle containing a sleeve with the sample into the combustion furnace.
- 3.32. **Injector Box** - The box assembly that houses the sample wheel.
- 3.33. **Instrument Detection Limit (IDL)** - The minimum quantity of analyte or the concentration equivalent which gives an analyte signal equal to three times the

- standard deviation of the background signal at the selected wavelength, mass, retention time, absorbance line, etc.
- 3.34. **K-Factor** - Instrument sensitivity factor in microvolts per microgram, calibrated using a calibration standard.
 - 3.35. **Laboratory Duplicates (LD1 and LD2)** - Two aliquots of the same sample taken in the laboratory and analyzed separately with identical procedures. Analyses of LD1 and LD2 indicate precision associated with laboratory procedures, but not with sample collection, preservation, or storage procedures.
 - 3.36. **Laboratory Reagent Blank (LRB)** - A matrix blank (i.e., a pre-combusted filter or sediment capsule) that is treated exactly as a sample including exposure to all glassware, equipment, solvents, and reagents that are used with other samples. The LRB is used to determine if method analytes or other interferences are present in the laboratory environment, the reagents, or the apparatus.
 - 3.37. **Laboratory Control Sample (LCS)** - A sample matrix, free from the analytes of interest, with verified known amounts of analytes from a source independent of the calibration standards or a material containing known and verified amounts of analytes. The LCS is generally used to establish intra-laboratory or analyst-specific precision and bias or to assess the performance of all or a portion of the measurement system. (NELAC)
 - 3.38. **Ladle** - Transports the capsule with the sample into a combustion furnace
 - 3.39. **Limit of Detection (LOD)** - The lowest concentration level that can be determined by a single analysis and with a defined level of confidence to be statistically different from a blank. This is also referred to as the MDL. (ACS)
 - 3.40. **Limit of Quantitation (LOQ)** - The minimum levels, concentrations, or quantities of a target variable (target analyte) that can be reported with a specified degree of confidence. The LOQ is set at 3 to 10 times the LOD, depending on the degree of confidence desired. This is also referred to as the Quantitation Limit.
 - 3.41. **Linear Dynamic Range (LDR)** - The absolute quantity over which the instrument response to an analyte is linear. This specification is also referred to as the Linear Calibration Range (LCR).
 - 3.42. **Material Safety Data Sheet (MSDS)** - Written information provided by vendors concerning a chemical's toxicity, health hazards, physical properties, fire, and reactivity data including storage, spill, and handling precautions.
 - 3.43. **May** - Denotes permitted action, but not required action. (NELAC)
 - 3.44. **Method Detection Limit (MDL)** - The minimum concentration of an analyte that can be identified, measured, and reported with 99% confidence that the analyte concentration is greater than zero.
 - 3.45. **Mixing Volume** - Spherical bottle in which sample gases become homogenous.
 - 3.46. **Mother Board** - The main printed circuit board. All CE-440 power supplies are located here.
 - 3.47. **Must** - Denotes a requirement that must be met. (Random House College Dictionary)
 - 3.48. **Precision** - The degree to which a set of observations or measurements of the same property, obtained under similar conditions, conform to themselves; a data quality indicator. Precision is usually expressed as standard deviation, variance or range, in either absolute or relative terms. (NELAC)

- 3.49. **Preservation** – Refrigeration, freezing and/or reagents added at the time of sample collection (or later) to maintain the chemical and or biological integrity of the sample.
- 3.50. **Pressure Transducer** - Used to check for leaks in the system and to monitor pressure in the mixing volume.
- 3.51. **P Valve** - The valve on the injector box of the horizontal auto-injector (HA) used to automatically purge the box.
- 3.52. **Profile** - Generated by the bridge signal. Used to help determine if a leak or malfunction occurs in the system.
- 3.53. **Quality Control Sample (QCS)** - A sample of analytes of known and certified concentrations. The QCS is obtained from a source external to the laboratory and different from the source of calibration standards. It is used to check laboratory performance with externally prepared test materials. Also referred to as CRM.
- 3.54. **Reduction Tube** - Quartz tube with reduced copper that removes excess oxygen from the sample gas and reduces oxides of nitrogen to free nitrogen.
- 3.55. **Response Factor (RF)** - The ratio of the response of the instrument to a known amount of analyte.
- 3.56. **Run** - One full sample analysis from start to finish, including printout.
- 3.57. **Run Cycle** - Typically a day or half day of operation - the entire analytical sequence of runs from the first run to the last run on the Sample Wheel.
- 3.58. **Sample Volume** - Tube where sample gas is exhausted from the mixing volume prior to entering the detector.
- 3.59. **Sample Wheel** – Sample holding device which contains up to 64 blanks, standards and samples. One wheel equals roughly 6 hours of run time, which is called the Run Cycle.
- 3.60. **Scrubber** - Removes water and carbon dioxide from the gas supplies.
- 3.61. **Sediment (or Soil) Sample** - A fluvial, sand, or humic sample matrix exposed to a marine, estuarine or fresh water environment.
- 3.62. **Sensitivity** - The capability of a test method or instrument to discriminate between measurement responses representing different levels (concentrations) of a variable of interest.
- 3.63. **Shall** - Denotes a requirement that is mandatory whenever the criterion for conformance with the specification requires that there be no deviation. (ANSI)
- 3.64. **Should** - Denotes a guideline or recommendation whenever noncompliance with the specification is permissible. (ANSI)
- 3.65. **Sleeve** - Nickel - to maintain integrity of the sample capsule and to protect the quartz ware from devitrification (to destroy the glassy qualities by prolonged heating).
- 3.66. **Standard Reference Material (SRM)** - Material which has been certified for specific analytes by a variety of analytical techniques and/or by numerous laboratories using similar analytical techniques. These may consist of pure chemicals, buffers, or compositional standards. The materials are used as an indication of the accuracy of a specific analytical technique. Also referred to as CRM.
- 3.67. **Trap** - Used for removing water and CO₂ from the sample gas.
- 3.68. **Tissue sample** – Plant or animal tissue dried and ground ready for weighing.
- 3.69. **Zero Value** - Bridge signal with only pure helium flowing through the detector.



4. INTERFERENCES



- 4.1. There are no known interferences for fresh, estuarine or coastal water or sediment samples. The presence of C and N compounds on laboratory surfaces, on fingers, in detergents and in dust necessitates the utilization of careful techniques (i.e., the use of forceps and gloves) to avoid contamination in every portion of this procedure (EPA.)

5. SAFETY

- 5.1. Safety precautions must be taken when handling reagents, samples and equipment in the laboratory. Protective clothing including lab coats and safety glasses and enclosed shoes must always be worn. In certain situations it may also be necessary to use gloves and goggles. If solutions or chemicals come in contact with eyes, flush with water continuously for 15 minutes. If solutions or chemicals come in contact with skin, wash thoroughly with soap and water. Contact Solomons Rescue Squad (911) if emergency treatment is needed. Inform the CBL Associate Director of Facilities and Maintenance of the incident if additional treatment is required.
- 5.2. The toxicity or carcinogenicity of each reagent used in this procedure may not have been fully established. Each chemical should be regarded as a potential health hazard and exposure should be as low as reasonably achievable. Cautions are included for known extremely hazardous materials and procedures.
- 5.3. High current and voltages are exposed near the furnaces, furnace control card, and mother board even while the CE-440 is OFF. If non-electrical trouble shooting is desired, remove the CE-440 line cord from the wall receptacle.
- 5.4. The combustion tube is brittle since it is fused quartz. Do not put any unnecessary stress on it.
- 5.5. The exterior of the furnace becomes extremely hot; do not touch it or the heat shield unless wearing appropriate gloves.
- 5.6. Do not wear any jewelry if electrically troubleshooting. Even the low voltage points are dangerous and can injure if allowed to short circuit.
- 5.7. The following hazard classifications are listed for the chemicals regularly used in this procedure.

TABLE 1.

Chemical	Health Hazard	Fire Hazard	Instability Hazard	Specific Hazard	
Acetanilide	1	1	0		
Atropine	4	0	0		

Magnesium Perchlorate	2	0	2	OX	
Ascarite (Sodium Hydroxide)	3	0	0	ALK, COR	
Silver vanadate on Chromosorb	3	0	0		
Silver oxide/Silver tungstate on Chromosorb	1	0	0		
Silver tungstate/Magnesium oxide on Chromosorb	0	0	0		
Copper wire	0	0	0		
<p>On a scale of 0 to 4 the substance is rated on four hazard categories: health, flammability, reactivity, and contact. (0 is non-hazardous and 4 is extremely hazardous)</p> <p><u>HAZARD RATING</u></p> <p>Health Hazard - Blue: 4 – deadly, 3 – extreme danger, 2 – hazardous, 1 – slightly hazardous, 0 – normal material</p> <p>Fire Hazard - Red: Flash Points: 4 – below 73° F, 3 – below 100° F, 2 – below 200° F, 1 – above 200° F, 0 – will not burn</p> <p>Instability Hazard - Yellow: 4 – may detonate, 3 – Shock and heat may detonate, 2 – violent chemical change, 1 – unstable if heated, 0 - stable</p> <p>Specific Hazard - White: Acid = ACID, Alkali = ALK, Corrosive = COR, Oxidizer = OXY</p>					

6. EQUIPMENT AND SUPPLIES

- 6.1. An elemental analyzer capable of maintaining a combustion temperature of 980°C and analyzing particulate and sediment samples for elemental carbon and nitrogen. The Exeter Model CE-440 is used in this laboratory.
- 6.2. A gravity convection drying oven, capable of maintaining 47°C ± 2°C for extended periods of time.
- 6.3. Muffle furnace, capable of maintaining 900°C +/- 15°C.
- 6.4. Ultra-micro balance that is capable of accurately weighing to 0.1 ug.
- 6.5. Vacuum pump or source capable of maintaining up to 10 in. Hg of vacuum.
- 6.6. Freezer, capable of maintaining -20°C ± 5°C.
- 6.7. 25-mm vacuum filter apparatus made up of a glass or plastic filter tower, fritted glass or plastic disk base and 2-L vacuum flask.
- 6.8. Flat blade forceps.
- 6.9. Labware - All reusable labware (glass, quartz, polyethylene, PTFE, FEP, etc.) must be sufficiently clean for the task objectives. Clean glassware by rinsing with reagent water; soaking for 4 hours or more in 10% (v/v) HCl and then rinsing with reagent water. Store clean. All traces of organic material must be removed to prevent carbon and nitrogen contamination.

7. REAGENTS AND STANDARDS

- 7.1. **Purity of Water** – Unless otherwise indicated, references to water shall be understood to mean reagent water conforming to ASTM Specification D 1193, Type I.
- 7.2. **Purity of Reagents** – Reagent grade chemicals shall be used in all tests. Unless otherwise indicated, it is intended that all reagents shall conform to the specifications of the Committee on Analytical Reagents of the American Chemical Society, where such specifications are available. Other grades may be used, provided it is first ascertained that the reagent is of sufficiently high purity to permit its use without lessening the accuracy of the determination.
- 7.3. **Acetanilide, 99.9% + purity**, C₈H₉NO (CASRN 103-84-4) - ACS grade acetanilide; primary standard used to calibrate the instrument
- 7.4. **Blanks** – Three blanks are used for the analysis. Two blanks are instrument related. The *instrument zero* response (ZN) is the background response of the instrument without sample holding devices such as capsules and sleeves. The *instrument blank* response (BN) is the response of the instrument when the sample capsule, sleeve and ladle are inserted for analysis without standard or sample. This is also the laboratory reagent blank (LRB) for standards and sediment or other weighed samples. The LRB for water samples includes the sleeve, ladle and a pre-combusted filter without standard or sample. These blanks are subtracted from the uncorrected instrument response used to calculate concentration. The third blank is the *laboratory fortified blank* (LFB.) For all sample analysis, a weighed amount of atropine or other certified standard is placed in an aluminum capsule and analyzed. The LFB may need to be recalculated with the correct instrument blank; this is dependent on the type of samples being analyzed and the original instrument blank type.
- 7.5. **Quality Control Sample (QCS)** – For this procedure, the QCS can be any assayed and certified sediment or particulate sample which is obtained from an external source. PACS-2 from the National Research Council of Canada is used by this laboratory. The laboratory fortified blank may also be considered a QCS.

8. SAMPLE COLLECTION, PRESERVATION AND STORAGE

- 8.1. **Water Sample Collection** – Samples collected for PNC analysis from fresh, estuarine and coastal waters are normally collected from a boat or pier using one of two methods; hydrocast or submersible pump systems. Follow the recommended sampling protocols associated with the method used. Whenever possible, immediately filter the samples as described in Section 11.1.1. Store the filtered sample in a labeled aluminum foil pouch and freeze at -20°C or store in a low temperature (47°C) drying oven after drying at 47°C ± 2°C, until use. If storage of the unfiltered water sample is necessary, place the sample into a clean bottle and store at 4°C until filtration is performed. Filter samples within 24 hours. Dry samples in a low temperature (47°C±2°C) drying oven prior to analysis.

- 8.2. The volume of water sample collected will vary with the type of sample being analyzed. Table 2 below provides a guide for a number of matrices of interest. If the matrix cannot be classified by this guide, collect 1 L of water from each site.
- 8.3. Sediment, Tissue, or Soil Sample Collection – Sediment samples are collected with benthic samplers. The type of sampler used will depend on the type of sample needed by the data-quality objectives. Tissue and soil samples are collected by a variety of methods. Store the wet sample in a clean labeled jar and freeze at -20°C until ready for analysis. Dry samples in a low temperature (47°C+/-2°C) drying oven, and grind to a homogenous powder with a mortar and pestle, prior to analysis.
 - 8.3.1. The amount of solid material collected will depend on the sample matrix. A minimum of 1 g is recommended.
 - 8.3.2. Filtration Volume Selection Guide

TABLE 2.

Sample Matrix	25mm Filter
Open Ocean	500 – 1000 ml
Coastal	400 – 500 ml
Estuarine (Low particulate)	250 – 400 ml
Estuarine (High Particulate)	25 – 200 ml

9. QUALITY CONTROL

- 9.1. The laboratory is required to operate a formal quality control (QC) program. The minimum requirements of this program consist of an initial demonstration of laboratory capability and the continued analysis of laboratory instrument blanks, field duplicates, and standards analyzed as samples as a continuing check on performance. The laboratory is required to maintain performance records that define the quality of data generated.
- 9.2. **Initial Demonstration of Capability**
 - 9.2.1. **The initial demonstration of capability (DOC)** – is used to characterize instrument performance (MDLs) and laboratory performance (analysis of QC samples) prior to the analyses conducted by this procedure.
 - 9.2.2. **Quality Control Sample (QCS/SRM)** – When using this procedure, a quality control sample is required to be analyzed at the middle and end of the run

(along with CCV standards) to verify data quality and acceptable instrument performance. If the determined concentrations are not within $\pm 3\sigma$ of the certified values, performance of the determinative step of the method is unacceptable. The source of the problem must be identified and corrected before proceeding with the initial determination of MDLs. It is possible the QCS/SRM may fall above or below control limits but still passes within $\pm 10\%$ of the certified values. This is still within acceptance limits.

- 9.2.3. **Method Detection Limits (MDLs)** – MDLs should be established for aqueous particulate carbon and nitrogen using a low level natural water sample. The same procedure should be followed for sediments or other weighed samples. To determine the MDL values, analyze seven replicates and process through the entire analytical procedure. Calculate the MDL as follows:

$$\text{MDL} = S t_{(n-1, 1-\alpha=0.99)}$$

Where,

S = Standard deviation of the replicate analyses.

n=number of replicates

$t_{(n-1, 1-\alpha=0.99)}$ = Student's *t* value for the 99% confidence level with n-1 degrees of freedom ($t=3.14$ for 7 replicates.)

- 9.2.4. MDLs should be determined annually, whenever there is a significant change in instrumental response or a new matrix is encountered.

9.3. Assessing Laboratory Performance

- 9.3.1. **Laboratory Reagent Blank (LRB)** – The laboratory must analyze at least one LRB (Section 3.37) with each batch of samples. For sediment samples the LRB consists of the ladle, sample sleeve and sample capsule, as there are no reagents involved in this procedure. For aqueous samples, the LRB consists of the ladle, sample sleeve and a pre-combusted filter of the same type and size used for samples. LRB data are used to assess contamination from the laboratory environment. For sediment samples, the blank value for carbon should not exceed $150\mu\text{v}$ and the blank value for nitrogen should not exceed $15\mu\text{v}$. For aqueous samples, the blank value for carbon should not exceed $300\mu\text{v}$ and the blank value for nitrogen should not exceed $15\mu\text{v}$.

- 9.3.1.1. If the nitrogen blank during a BLANK analysis is in excess of 2000% the nitrogen blank in memory the “COPPER APPEARS SPENT” warning is printed. If the nitrogen blank increased over $100\mu\text{v}$ over BN in memory and the first STANDARD KC/KN is more than any following STANDARD KC/KN by $0.2\mu\text{v}/\text{ug}$, then a “COPPER APPEARS SPENT” warning will be printed either during a BLANK analysis or a STANDARD analysis. Maintenance will be required.

- 9.3.1.2. The Reagent Blank Control Chart is constructed from the average and standard deviation of Reagent Blank measurements recorded annually. This includes both filter pad blanks and capsule blanks. The accuracy chart includes upper and lower warning levels ($WL=\pm 2s$) and upper and lower control levels ($CL=\pm 3s$). The standard deviation (*s*) is specified relative to statistical confidence levels of 95% for WLs and 99% for

CLs. Enter Reagent Blank results on the chart each time the Reagent Blank is analyzed.

9.3.2. Quality Control Sample (QCS)/ Standard Reference Material (SRM) -

When using this procedure, a quality control sample is required to be analyzed at the middle and end of the run, to verify data quality and acceptable instrument performance. The QCS will be obtained from a source external to the laboratory and different from the source of calibration standards. If the determined concentrations are not within $\pm 3\sigma$ of the certified values, performance of the determinative step of the method is unacceptable. The source of the problem must be identified and corrected before either proceeding with the initial determination of MDLs or continuing with the analyses. Corrective action documentation is required for all data outside $\pm 3\sigma$. The standard deviation data should be used to establish an on-going precision statement for the level of concentrations included in the QCS. This data must be kept on file and be available for review. Values for QCSs should be plotted with the other control data. The sample weight of the SRM should mirror that of the unknown samples (~10 mg).

9.3.2.1. The Accuracy Control Chart for QCS/SRM samples is constructed from the average and standard deviation of QCS/SRM measurements recorded annually. The accuracy chart includes upper and lower warning levels ($WL=\pm 2s$) and upper and lower control levels ($CL=\pm 3s$). These values are derived from stated values of the QCS/SRM. The standard deviation (s) is specified relative to statistical confidence levels of 95% for WLs and 99% for CLs. Set up an accuracy chart by using $\pm 10\%$ in addition to $\pm 3s$ since the concentration of the QCS/SRM varies. Enter QCS/SRM results on the chart each time the sample is analyzed.

9.4. **Assessing Analyte Recovery** - Percent recoveries cannot be readily obtained from particulate samples. Consequently, accuracy can only be assessed by analyzing check standards as samples (CCV, QCS/SRM).

9.5. Data Assessment and Acceptance Criteria for Quality Control Measures

TABLE 3.

QC INDICATOR	ACCEPTANCE LIMITS	ACTION	FREQUENCY (BATCH)
K-factor	KC = 18 to 25 18 to 25 $\mu\text{v}/\mu\text{g}$ is manufacturer's recommended limits. KN = 7 to 10 $\mu\text{v}/\mu\text{g}$ 7 to 10 $\mu\text{v}/\mu$ is manufacturer's recommended limits.	The k-factors must be within the specified limits or the standard must be reanalyzed. (see 10.3)	3 per batch to acquire an acceptable K-factor calibration range.
Initial Calibration Verification (ICV)	$\pm 10\%$	Qualify data if not within acceptance limits. Rejection criteria for batch.	At the beginning of a run immediately following the calibration.
Quality Control Sample (QCS)/	$\pm 10\%$	If QCS is outside acceptance limits, qualify	After every 25 samples.

Certified Reference Material (CRM)		the data for all samples back to last acceptable QCS.	
Continuing Calibration Verification (CCV)	± 10%	Qualify data if not within acceptance limits. Rejection criteria for batch. May be CRM or Atropine standard.	After every 25 samples.
Method Blank/Laboratory Reagent Blank (LRB)	<i>Filter Pad Blanks:</i> BC < 300 µv BN < 15 µv <i>Capsule Blanks:</i> BC < 150 µv BN < 15 µv	If the blank value is greater the acceptable value, replace and rerun the blanks.	At the beginning and end of a run. LRB may be a filter pad or capsule blank.
Field Duplicate	± 30%	Duplicate sample data must be within ± 30% or be qualified. All duplicates for this procedure are field duplicates and are more a measure of field collection and filtration techniques.	

9.6. Corrective Actions for Out-Of-Control Data

- 9.6.1. All samples must be qualified when external QC samples are out of control.
- 9.6.2. All samples between QCSs that are out of control must be qualified.
- 9.6.3. All problems with analytical runs must be documented on the bench sheet.

9.7. General Operation

- 9.7.1. To assure optimal operation and analytical results, it is advisable to track the stability of the instrument. Of primary importance is the precision and repeatability of standard and blank values during the course of a day of operation. Thus, a standard (as an unknown) should be inserted approximately every twenty five samples. Try to use different standards for QA in order to assure the validity of the calibration values over the entire operating range of the instrument.

10. CALIBRATION, STANDARDIZATION and CALCULATIONS

- 10.1. Calibration - Daily calibration procedures must be performed and evaluated before sample analysis may begin. Single point calibration is used with the Exeter Model CE-440 Analyzer.
- 10.2. Establish single calibration factors (K) for each element (carbon, hydrogen, and nitrogen) by analyzing three weighed portions of calibration standard (acetanilide). The mass of the calibration standard should provide a response within 20% of the response expected for the samples being analyzed. Calculate the (K) for each element using the following formula:

$$Kfactor (\mu v / \mu g) = \frac{RN - ZN - BN}{M(T)}$$

Where: RN = Instrument response to standard (µv)
 ZN = Instrument zero response (µv)

BN = Instrument blank response (μv)
M = Mass of standard matter in μg
T = Theoretical % C, N, or H in the standard. For acetanilide %C = 71.09, %N = 10.36 and %H = 6.71.

- 10.3. The detector generates a signal directly proportional to the compound of interest in the sample. The following formula is used to calculate carbon, nitrogen and hydrogen concentrations in unknown samples.

$$\% = \frac{1}{K} \times \frac{1}{W} \times (R - Z - B) \times 100$$

Where

K = calibration factor for the 440 instrument
W = sample weight
R = read signal of sample gas
Z = zero reading or base line of instrument
B = blank signal generated by instrument itself, including ladle and capsules

- 10.4. The K-factor is established by running samples of a known standard. The default value is for acetanilide, which is used as the standard:

Acetanilide C = 71.09% H = 6.71% N = 10.36%

If another standard is used, the values will need to be entered into the computer using the Edit Standards function in the Customizing Menu.

- 10.4.1. Once the blank values have been established and entered into memory, proceed to run known standards to arrive at the calibration factors for carbon and nitrogen for the instrument.
- 10.4.2. Run a minimum of three standards, average the results, and enter into computer memory, or use the automatic enter mode. During the run, standards may be entered as samples to verify the K-factors and blanks.
- 10.4.3. Any time a STD1 is entered as sample ID the computer calculates and enters a new set of operating Ks based on a weighted formula using the last three sets of Ks in memory. This occurs only if all three Ks fall within the following windows:

$$\text{New KC} = \text{KC in memory} \pm 1.0$$

$$\text{KN} = \text{KN in memory} \pm 0.5$$

- 10.4.3.1. It is important that the Ks in memory be close to expected values or new Ks generated will not be within the window and therefore will not be accepted for automatic insertion.
- 10.4.3.2. The weighted formula for calculating the Ks:

$$K = k^1 + (0.5 \times k^2) + \frac{(0.25 \times k^3)}{1.75}$$

where:

k^1 = k found in this run

k^2 = Next k in memory

k^3 = Last k in memory

- 10.5. **Conditioner** - Before injecting any samples or blanks, it is necessary to run one or more conditioners. The purpose of the conditioner runs is to coat the walls of the system surfaces, especially the mixing and sample volume, with water vapor, carbon dioxide and nitrogen which simulates actual sample running conditions. To simulate this condition as closely as possible, it is advisable to use conditioners of approximately the same weight as the samples. Always inject a conditioner before a standard.
- 10.6. **Blanks** - The blank value used in the calculation is the total signal generated by the system including the ladle and sample capsule. This blank should always be analyzed immediately after a weighed conditioner to represent a true blank of the instrument. Never use the blank value from an empty wheel since the system dries up and the blank value would be lower than normal. The instrument program will only accept blanks if they fall within the following:
New BC < 500
New BN < 250
- 10.7. **K-Factors** - Once the blank values have been established and entered into memory, proceed to run known standards (acetanilide) in order to establish the calibration factors for carbon, hydrogen and nitrogen. The computer will calculate K-factors as long as STD# has been entered as the sample ID. Run a minimum of three (3) standards, average the results, and enter into the computer memory, or use the automatic enter mode. To verify that the instrument is running well, all the individual K-Factor values should be within +/- 0.08 of the mean. The instrument is now ready to analyze samples. Acetanilide standards may be analyzed as unknowns verify the K-factors and blank values; atropine and PACS-2 already serve as a calibration check and are analyzed throughout the run cycle.

11. PROCEDURE

11.1. Aqueous Sample Preparation

11.1.1. Water Sample Filtration

Pre-combust 25-mm GF/F glass fiber filters at 500°C for 1.5 hours. Store filters covered, if not immediately used. Place a pre-combusted filter on a fritted filter base of the filtration apparatus and attach the filtration tower. Thoroughly shake the sample container to suspend the particulate matter. Measure and record the required sample volume using a graduated cylinder. Pour the measured sample into the filtration tower. Filter the sample using a vacuum no greater than 10 in. of Hg. Vacuum levels greater than 10 in. of Hg can cause cell rupture. Do not rinse the filter following filtration. It has been demonstrated that sample loss occurs when the filter is rinsed with an isotonic solution or the filtrate. Air dry the filter after the sample has passed through by continuing the vacuum for 30 sec. Using flat-tipped forceps, fold the filters in half while still on the base of the filter apparatus. Store filters as described in Section 8.1.

- 11.1.2. If the sample has been stored frozen in foil pouches, place in a drying oven at 47°C ± 2°C for 24 hours before analysis. Slightly open the pouch to allow

drying. When ready to analyze, fold, and insert the filter into a pre-combusted nickel sleeve using forceps. Tap the filter pad down into the nickel sleeve using a clean stainless steel rod. The sample is ready for analysis.

11.2. Sample Analysis

11.2.1. As the filters are packed into the nickel sleeves they are placed into the 64 position sample wheel. The calibration series must be placed at the beginning of the batch. The sample schedule consists of a conditioner, a blank, a conditioner and three standards. ACS grade acetanilide 99.9% + purity must be used to calibrate the instrument.

11.2.2. Set up the sample tray in the following manner (used for aqueous samples):

TABLE 4.

Position #	Contents	Notes	Type	Weight, ug
1	Conditioner	Acetanilide (1500-2500 µg)	Conditioner	Weight of Acetanilide
2	Conditioner	Acetanilide (1500-2500 µg)	Conditioner	Weight of Acetanilide
3	Capsule + sleeve	Blank	Blank	0
4	Conditioner	Acetanilide (1500-2500 µg)	Conditioner	Weight of Acetanilide
5	Standard	Acetanilide (1500-2500 µg)	STD1 ^a	Weight of Acetanilide
6	Standard	Acetanilide (1500-2500 µg)	STD1	Weight of Acetanilide
7	Standard	Acetanilide (1500-2500 µg)	STD1	Weight of Acetanilide
8	Sleeve +capsule+ standard	Atropine (1500-2500ug)	LFB	Weight of Atropine
9	Sleeve + filter pad	Filter Blank	LRB	0
10-34	Samples			Volume filtered/10
35	Sleeve +capsule+ standard	PACS-2 (8000-15,000ug)	QCS/SRM	Weight of PACS-2
36-60	Samples			Volume filtered/10
61	Capsule + Sleeve	Blank	Blank	0
62	Sleeve + capsule+ standard	Atropine (1500-2500ug)	LFB	Weight of Atropine
63	Sleeve + capsule+ standard	PACS-2 (8000-15,000ug)	QCS/SRM	Weight of PACS-2
64	Capsule + Sleeve	Blank	Blank	0

^a Always use STD1 in the Standard position. The system recognizes this as acetanilide and makes the appropriate calculations for the K factor.

11.2.3. By entering volume filtered/10 for the weight of the aqueous filtered samples, results printed out represent micrograms of carbon or nitrogen per liter. This corresponds directly to the known amount of liquid that has passed through the filter. The maximum sample capacity per run is approximately 4,000 to 5,000

micrograms of carbon on the filter pad. Filters containing more than that amount may be cut in half and analyzed separately and the results added.

11.2.4. Filter Preparation for Analysis

11.2.4.1. Work on a clean, non-contaminating surface.

11.2.4.2. Using two pairs of clean forceps, fold the filter in half so that the exposed surface is inside. Continue folding the filter in half until you have a compact package.

11.2.4.3. Place a pre-combusted 7 x 5 mm nickel sleeve into the filter loading die, which functions as a holding device. Use the clean 4 mm loading rod to force the compressed filter through the clean loading funnel and into the nickel sleeve.

11.2.4.4. Make sure no excess filter protrudes above the lip of the sleeve.

11.2.4.5. Place loaded sleeve in the 64-sample wheel.

11.2.5. Determination of Particulate Organic and Inorganic Carbon

11.2.5.1. Thermal Partitioning is the method used to partition organic and inorganic carbon. The difference found between replicate samples, one of which has been analyzed for total PC and PN and the other of which was muffled at 550°C for three hours to drive off organic compounds, and then analyzed for PC and PN, is the particulate organic component of that sample. This method of thermally partitioning organic and inorganic PC may underestimate slightly the carbonate minerals' contribution in the inorganic fraction since some carbonate minerals decompose below 500°C, although CaCO₃ does not. This method is used for filtered samples where at least two filters per sample must be supplied. For sediment samples at least 1 g of sample is required and at least 0.5g of sample is weighed into a crucible of known weight. The weight is recorded. The crucible is then muffled as above, and weighed again. The percent remaining of the ash is calculated and multiplied times the %C in the ash which is then determined by the CE-440.

12. DATA ANALYSIS AND CALCULATIONS

12.1. Raw results are printed. These data are then exported from the instrument computer to the analyst computer by a flash drive. The data is then entered into an Excel spreadsheet. Results are reported in mg/L for aqueous samples, and in % for sediment or other weighed samples, standards and SRMs or QCSs.

12.2. Recalculation of data (if necessary)

12.2.1. The software gives the analyst the opportunity to recalculate values generated by the run. This option can be useful for adjusting the values of the data due to explained or unexpected changes in the blank or calibration (K) factor during an analytical run cycle. Blanks can change due to sample handling, different capsules or sleeves, small leaks in the system and contamination. K factors should remain stable but can drift due to flow changes caused by variable pressure drops in the traps or helium scrubber, or by changing delivery pressure at the helium regulator.

12.2.2. Before the analyst can change calibration values and recalculate the results, there must be a valid reason. When data is recalculated, always document the incident.

12.3. Example of Excel spreadsheet of results:

	A	B	C	D	E	F	G
1	3/31/2017						
2	ANALYST NAME						
3	CLIENT						
4	RECEIVED DATE						
5							
6	SAMPLE ID	PC, mg C/L	PN, mg N/L	ERROR			
7	SAMPLE1	0.8340	0.1420				
8	SAMPLE2	0.7070	0.1090				
9	SAMPLE3	0.6600	0.1010				
10	SAMPLE4	0.6890	0.1030				
11	SAMPLE5	0.7720	0.0869				
12	SAMPLE6	0.2600	0.0513				
13	SAMPLE7	0.2720	0.0435				
14	SAMPLE BLANK	0.00	0.00	ug/pad			
15							
16	LAB DUPS	PC, mg C/L		PN, mg N/L			
17	SAMPLE ID	DUP 1	DUP 2	DUP 1	DUP 2		
18	SAMPLE4	0.7000	0.6780	0.1070	0.0993		
19							
20	BLANKS C=	235	K VALUES C=	22.097			
21	N=	9	N=	8.055			
22							
23	QC NAME	ACTUAL		EXPECTED	% RECOVERY		
24		%C	%N	%C	%N	%C	%N
25	ATROPINE	69.21	4.81	70.56	4.84	98.1	99.4
26	ATROPINE	70.40	4.93	70.56	4.84	99.8	101.9
27	PACS2	3.24	0.29	3.21	0.29	100.9	100.0

12.3.1. Cell 1A - Analysis date

12.3.2. Cell 2A – Analyst’s name

12.3.3. Cell 3A – Sample source or client

12.3.4. Cell 4A – Sample or Received date

12.3.5. Cell 6A – Column heading for Sample

12.3.6. Cell 6B – Column heading for C concentration

12.3.7. Cell 6C – Column heading for N concentration

12.3.8. Cell 6D – Column heading for errors and qualifiers

12.3.9. Cells 7A to 14D – Sample Results table

12.3.10. Cells 16A to 18E – QC table for field duplicates. The mean of these values is reported in the sample results table

12.3.11. Cells 20A to 21D – Instrument values for the Blanks and Ks.

12.3.12. Cells 23A to 27G- Values for CCV/QCS/SRM samples and percent recoveries for each day of analyses.

- 12.4. Sample data should be reported in units of mg/L as carbon or nitrogen for aqueous samples, and as percent carbon or nitrogen for sediment samples.
- 12.5. Report analyte concentrations to three significant figures for both aqueous and sediment samples.
- 12.6. For aqueous samples, calculate the sample concentration using the following formula:
$$\text{Concentration (mg / L)} = \frac{\text{Corrected sample response}(\mu\text{g / L})}{1000\mu\text{g / mg}}$$
- 12.7. For weighed samples, % N or %C are already calculated by the instrument software.

13. POLLUTION PREVENTION

- 13.2. Pollution prevention encompasses any technique that reduces or eliminates the quantity of toxicity of waste at the point of generation. Numerous opportunities for pollution prevention exist in laboratory operation. The USEPA has established a preferred hierarchy of environmental management techniques that places pollution as the management option of first choice. Whenever feasible, laboratory personnel should use pollution prevention techniques to address their waste generation. When wastes cannot be feasibly reduced at the source, the agency recommends recycling as the next best option.
- 13.3. For information about pollution prevention that may be applicable to laboratories and research institutions, consult “Less is Better: Laboratory Chemical Management for Waste Reduction”, available from the American Chemical Society, Department of Government Relations and Science Policy, 1155 16th Street N. W., Washington, D.C. 20036.

14. WASTE MANAGEMENT

- 14.1. The reagents used in this procedure are minimal and are not hazardous with the exception of the ascarite and magnesium perchlorate. Due to the small quantity of ascarite and magnesium perchlorate used, the spent reagent can be flushed down the drain with running water.
- 14.2. For further information on waste management consult The Waste Management Manual for Laboratory Personnel, available from the American Chemical Society.

15. REFERENCES

- 15.1. U.S. Environmental Protection Agency, 1997. Methods for the Determination of Chemical Substances in Marine and Estuarine Environmental Samples. Method 440.0. U.S. Environmental Protection Agency. Washington, D.C.
- 15.2. Holme, N.A. and A.D. McIntyre (eds.). 1971. Methods for the Study of Marine Benthos. International Biome Program. IBP Handbook #16. F.A. Davis Co., Philadelphia, PA.

- 15.3. Hurd, D.C. and D.W. Spencer (eds). 1991. Marine Particles: Analysis and Characterization. Geophysical Monograph: 63, American Geophysical Union, Washington, D.C. 472p.
- 15.4. Hirota, J. and J.P. Szyper. 1975. Separation of total particulate carbon into inorganic and organic components. *Limnol and Oceanogr.* 20:896-900.
- 15.5. Grasshoff, K., M. Ehrhardt and K. Kremling (eds). 1983. *Methods of Seawater Analysis.* Verlag Chemie.
- 15.6. Keefe, Carolyn W., The Contribution of Inorganic Compounds to the Particulate Carbon, Nitrogen and Phosphorus in Suspended Matter and Surface Sediments of the Chesapeake Bay, *Estuaries*, Vol. 17, No 1B, pp 122-130, March 1994.
- 15.7. 40 CFR, Part 136, Appendix B. Definition and Procedure for the Determination of the Method Detection Limit. Revision 1.11.
- 15.8. Zimmermann, C. F., Keefe, C. W., and Bashe, J. 1997. Method 440.0. Determination of Carbon and Nitrogen in Sediments and Particulates of Estuarine/Coastal Waters Using Elemental Analysis. USEPA

TABLE 5

PC/PN BENCH SHEET

WHEEL LABEL:

PREP DATE:

ANALYST:

ANALYSIS DATE:

HOLE NO	ID	VOL OR WT	ADDITIONAL	HOLE NO	ID	VOL OR WT	ADDITIONAL
1	COND			51			
2	COND			52			
3	CAP BL			53			
4	COND			54			
5	STD1			55			
6	STD1			56			
7	STD1			57			
8	ICV ATROPINE			58			
9	ICB FP BL			59			
10				60			
11				61	CAP BL		
12				62	CCV ATROPINE		
13				63	CRM PACS2		
14				64	CAP BL		
15							
16							
17							
18							
19							
20							
21							
22							
23							
24							
25							
26							
27							
28							
29							
30							
31							
32							
33							
34							
35	CRM PACS2						
36							
37							
38							
39							
40							
41							
42							
43							
44							
45							
46							
47							
48							
49							
50							

FILES CREATED:

Exeter Analytical/CE440

Appendix

Initial Start-Up

The following sequence should be followed when initially starting up the Exeter CE-440 Elemental Analyzer or when restarting after a shutdown. Make sure the power switches on the computer and on the CEC-490 (Interface) are off. Remove the CE-440 cover from instrument. Check that the helium regulator is set at 18 psig and oxygen at 20 psig and open the in-line gas valves. If restarting, check that the combustion and reduction tubes, scrubber and traps are not exhausted. Turn the selector switch to SYSTEM. Turn on the CEC-490 and the computer. If this is a cold re-start, set combustion and reduction furnace temperature controls to values previously established. Wait until the reduction furnace has reached operating temperature. **DO NOT PUSH DETECTOR RESET BUTTON AT THIS TIME!** If the tubes need to be replaced, go to "Tube Replacement" in the Service Menu, then follow the directions under "Combustion Tube Replacement" to purge the helium and oxygen regulators twice. This will also serve the purpose of conditioning the reduction and combustion tubes. Then go to Main Menu and install the end connectors.

After allowing the CE-440 oven to reach operating temperature (about one hour) go to the Service Menu and select Calibrate CEC-490. Calibrate all and follow instructions. Run 2 to 3 blanks to establish a fill time of about 20 to 40 seconds. If the fill time has been exceeded, increase the helium pressure and repeat this step until fill time is achieved. Helium pressure should be at about 12-18 psig. (This is dependent on regulator type.) If the system still aborts, go through the leak test mode.

Make certain that helium gas is flowing by checking that the tank is open and the regulator is set to the correct pressure before pressing the DETECTOR RESET button. After the first accepted blank, push DETECTOR RESET. High concentrations of air or oxygen in the system will damage the filaments in the detectors if power is applied. To protect the detectors, a detector safety circuit is provided which shuts off power when the helium carrier gas becomes contaminated with air or oxygen at levels generating an imbalance of about 450 μ v or higher. The safety circuit will activate should leaks develop or when the helium supply is depleted. The safety circuit monitors the gross imbalance between the two sides of the nitrogen bridge. If air or oxygen is present on both sides of the bridge, the safety circuit may not activate and damage to the detectors may occur. The safety circuit is also activated when accidental or deliberate power interruption occurs. If power has been interrupted for more than 5 minutes, do not push DETECTOR RESET until the system has performed a blank run. Do not hold the DETECTOR RESET button in more than one second. If the light stays on when the button is released, continue with additional blank runs as necessary before pushing the button again. Go through one blank run before turning on the detector.

Once the detector has been reset, go to the Service Menu and monitor the bridge readings. Adjust the "zero" reading to approximately 2500 μ v by turning the respective potentiometers on the Bridge Balance Card located in the left rear corner of the Motherboard. (To access these systems, the instrument cover must be removed.) Typically the bridges should be set well above negative or zero (approximately + 2500 μ v). This is after the instrument has stabilized. Stability is based on furnace and oven temperatures being steady for a period of

not less than 1 hour. Check the furnace and oven temperatures. If these have reached operating levels, let the instrument go through another three sets of blanks in order to purge the system and condition the reagents. This can be done through the CHN Run Mode (Run Menu). Make sure the B-valve is ON to run oxygen and run blanks until (a) BC and BN are less than 200 μ v and BH is less than 1500 μ v, and (b) consecutive BC/BN agrees to 10 μ v and BH to 50 μ v. It may take time for BH to settle. Go to the Service pull down Menu and calibrate all of the CEC-490 again. The instrument is now ready for system calibration with known standards.

Standby Mode

To reduce helium consumption and minimize wear on the terminal screen, the overnight standby mode is used. Select the overnight standby mode (in the Run pull-down menu). To return to normal operation, select Stop Overnight Standby.

Powering Down

It is preferable for the system to remain powered up at all times since this will extend the life time of the glassware, reagents, and electronics. However, helium and power will be consumed during this standby and it might be necessary to power down the CE-440 instrument. To assure minimum disruption for a future start up after a power down, proceed as follows:

- Turn the furnace temperature controllers to zero.
- Allow several hours for the furnace temperatures to drop below 100°C.
- Turn off the power to the instrument as well as gas valves between the instrument and the regulators.
- Turn off the gas on the cylinder.

To Start a Run

Select "Run" from the menu and continue as described below.

- Select "Carbon, Hydrogen, Nitrogen Run". Select "Yes" for a new run
- Check "Enter the Ks and Blanks automatically". Enter date followed by AM or PM as appropriate for the message of this run series. Select "Enter Data".
- Sample Entry Screen: Enter Weight (μ g): when entering the weight of the sample press [ENTER] to use the present weight or enter a new weight. If a weight of zero [0] is entered then the ID is assumed to be a blank. If a weight of 100 has been entered the results will be reported in micrograms (μ g). When analyzing aqueous samples, enter the volume filtered (milliliters)/10 as the weight. The results will be reported in μ g /L. When analyzing sediment samples or weighed QC samples, enter the weight in μ g. The result will be reported in %.
- Enter Sample ID: enter the sample ID as either STD1, blank, or any other text. If STD1 is entered as the first three letters, then Ks will be calculated on the result report. If blank is entered, then blanks will be calculated.
- Use the PC/PN bench sheet to set up a wheel. (See Table 5)
- Press "Start Run"

To Insert a Wheel

This mode opens the A, D, F and C valves allowing helium to enter the injection box and minimize air in this area while installing the sample wheel for the 64 sample automatic injector. The pressure will build up and eventually equilibrate to the helium tank pressure if the instrument is left in this mode for a long period of time. This is not recommended; therefore, do not delay carrying out the following steps.

- Open the manual purge valve on the injector box (right side, behind the P valve) to relieve the internal pressure. Loosen the 4 cover screws and lift the lid. Remove the empty wheel from the sample chamber.
- Blow out with canned air any material that might be in the box from previous run.
- Insert the loaded sample wheel with the locking pin in place. Tilt the wheel slightly, line up the scribe mark on the wheel with the ratchet in the housing, lower the wheel and make sure that it is properly seated. Place the locking pin in the center hold. Check that the o-ring of the cover is clean and well seated in the groove.
- Close the cover and tighten equally on all four screws. This should be performed in an alternating sequence to achieve a uniform seal. Never over-tighten or use any tools on the screws.
- Open and remove any spent capsules in the capsule receiver located under the sample chamber. Re-grease the gasket if needed and re-install cover.
- Close the purge valve, let pressure build up for about 30 seconds. Re-open the purge valve for about 5 seconds and then close again.
- Select "OK" to continue operation.

Sample Run

The sample is automatically injected into the combustion tube at the appropriate time. Upon completion of the fill time the ladle is retracted and allowed to cool. At the end of the run the results are printed and the soft key commands are followed if any have been selected.

Once the run begins, the screen displays the following information:

Run number, Sample Weight and ID., the operating K and B values, the preset combustion and purge times, valve status, and the elapsed time in minutes:seconds. Temperatures and Pressure are also displayed near the bottom of the screen. These numbers may not be updated all of the time as time critical sections of a run occur. Run counters for the various tubes are displayed above the valve status diagram. The run counters will change from white to red when they approach 10% within the thresholds set by the user.

During the run the analyst has various options available through the buttons at the top of the screen (accessed via simply selecting one). If a key is actuated, the button changes from grey to white. The buttons are for the following functions:

- **Ks & Bs** - To access the Ks and Bs table at the end of the current run. This allows the operator to change the operating values.
- **PARAMETERS** - Goes to parameters table at the end of the current run.
- **LEAK TEST** - The leak test program is activated at the end of the run cycle.

- **STANDBY** - At the end of the run cycle the instrument will go into standby.
- **DATALOG** - At the end of the run cycle a datalog is printed every half hour. A, D, and F valves are turned on, as in the overnight standby mode.
- **SSI** – A function to activate the single sample inject program after the completion of the current run. The program will automatically resume after the SSI run (unless SSI is pressed again).
- **MENU NEXT** - Goes to the Analytical Menu at the end of the current run. The data will be stored on the data disc at that point.
- **STOP** - Aborts the current operation and goes to the Analytical Menu. This is typically only used during emergency operations. If you exit an HA run cycle prematurely and you wish to start over or resume the HA run with the sample IDs and weights already in memory, then DO NOT exit the Analytical Menu. If you exit or reboot the Analytical Menu then the IDs and weights will be erased.
- **NONE** – Nothing at end of run or run cycle.

Tube Replacement

This mode is used when one or more of the reagent tubes in the CE-440 need to be changed, as indicated by the maintenance schedule, poor analytical results or in the case of a cold restart. See instrument manual for additional details on tube replacement beyond this appendix.

Go to the Service Pull-down Menu. Select “Tube Replacement.” “Select CHN Analysis.” Another menu will be displayed that will contain options for tube packing information or for replacement of any tubes used for that analysis. If a new gas cylinder or regulator is to be replaced, select the appropriate item from the menu for changing a tank.

In the individual tube replacement options, follow the step by step instruction shown on the screen. If the procedure is followed correctly and to its conclusion, the Maintenance Schedule Information for that tube will be reset. You can return to the Service Menu at any point by pressing “End.”

Combustion Tube

Hold the tube vertically with the short end from the indentation up. Roll up a piece of platinum gauze so that it will fit snugly into the combustion tube. Slide the gauze plug into the tube and up against the indentation. Add a small plug of quartz wool. (Quartz wool may be muffled for one hour at 850 °C to remove any residual carbon). Add 1½ inches of silver tungstate/magnesium oxide on Chromosorb. Gently tap the tube to prevent the reagent from channeling. Add a small plug of quartz wool. Add 2 inches of silver oxide/silver tungstate on Chromosorb. Tap the tube and add another small plug of quartz wool. Add 2 inches of silver vanadate on Chromosorb. Tap the tube and add another plug of quartz wool. Slide a rolled-up piece of silver gauze into the tube and pack against the quartz wool. Make sure that there is no less than ½ inches of space between the end of the tube and the silver gauze since the silver gauze will conduct heat and damage the o-ring on the end connector. There is rarely such a thing as a “too tightly” packed combustion tube. Loosely packed combustion tubes can cause non-linearity.

- Silver Vanadate on Chromosorb: Reacts with and removes chlorine, bromine, iodine and sulfur contained in the combustion gases. When absorbing sulfur, it changes color from yellow to dark brown when saturated. In absorbing halogens, exhaustion of the silver vanadate is indicated by color changes on the surface of the silver gauze at the end of the combustion tube. Each element forms a distinctively colored salt deposit – silver chloride is gray, silver bromide is brown, and silver iodide is purple.
- Silver Tungstate/Magnesium Oxide on Chromosorb: Removes fluorine, phosphorus, and arsenic.
- Silver Oxide/Silver Tungstate on Chromosorb: Removes sulfur and halogens (except fluorine).
- The silver gauze can be cleaned with water and a small amount of dish soap; swirl for about five minutes, rinse the gauze multiple times with tap water then rinse again with laboratory reagent water. Rinse the gauze with acetone for 30 seconds then dump the waste. Air-dry the gauze thoroughly. Finish by muffling at 550°C for 30 minutes.

Reduction Tube

Pack about ¾ inches of quartz wool into the bottom of the tube from the opposite end. Fill the tube with copper wire while gently tapping to tightly settle the copper and avoid channeling. Pack another plug of quartz wool into the tube against the copper. Insert a rolled-up piece of silver gauze into each small diameter tube end.

Perform a leak test of the combustion-reduction area after tube replacement.

Carbon Dioxide Trap and Gas Scrubbers (2)

These three tubes are identically packed even though the scrubbers are a larger diameter. Pack a ¼ inches plug of quartz wool into one end of the tube. Add 3½ inches Ascarite (Colorcarb) while gently tapping the tube. Add ¼ inches plug of quartz wool. Add 1½ inches magnesium perchlorate while gently tapping the tube. Add ¼ inches plug of quartz wool. There should be about ¼ inches of free space at each end of the tube. Gas scrubbers should be loosely packed to allow for the high gas flows associated with the CE-440. Note the orientation (in the instrument) of the helium and oxygen scrubbers versus the CO₂ trap. The orientation is reversed for the CO₂ trap.

Water Trap

Pack a ¼ inches plug of quartz wool into one end of the tube. Add magnesium perchlorate while gently tapping the tube. Add ¼ inches plug of quartz wool. There should be about ¼ inches of free space at each end of the tube.

Fill time should always be checked after replacing traps and scrubbers. The instrument should be conditioned after replacing maintenance by running two blanks before proceeding to a sample run.

Important Factors for Proper CE-440 Operation

- Oxygen pressure should be at ~ 20 psig.
- Helium pressure should be at ~ 12-18 psig and the fill time for a run should be between 20 and 40 seconds. (This is dependent on regulator type.)
- When greasing o-rings or gaskets, it is recommended to use Krytox (R) by Dupont.
- The furnace temperatures reach set temperature very quickly.
- Never set the combustion temperature above 1100 °C.
- Never set the reduction temperature above 900 °C.

UNIVERSITY OF MARYLAND CENTER FOR ENVIRONMENTAL SCIENCE
CHESAPEAKE BIOLOGICAL LABORATORY
NUTRIENT ANALYTICAL SERVICES LABORATORY
146 Williams St., Solomons MD 20688
<http://nasl.cbl.umces.edu/>

Determination of Total Particulate Phosphorus (TPP) and Particulate Inorganic Phosphorus (PIP) in Fresh/Estuarine/Coastal Waters

(Reference Method: EPA 365.1, Rev. 2.0)

**Revision 2017-1.
Replaces revision 2015.
Effective April 26, 2017**

Revised by: _____ Date: _____

Reviewed by: _____ Date: _____

Laboratory Supervisor: _____ Date: _____

Revisions 2017

Section 1.0: Added a section with details on the MDL for sediment samples.

Section 1.4: Updated PIP MDL from 0.0024 to 0.0021 mg P/L.

Sections 1.6 & 1.7: Updated quantitation limit for TPP and PIP to 0.0063 (or 3xMDL).

Section 1.8: Updated concentration range lower limit from 0.0070 to 0.0021 (TPP MDL).

Section 1.11: Replaced “conforms to” with “references”.

Section 3.4: Updated the analytical ranges to current practices.

Section 3.5: Updated batch definition.

Section 3.12.3: Changed analysis every 15-20 samples to every 18-23 samples.

Section 7.3: Updated preparation instructions for 1N HCl.

Section 7.9: Updated preparation instructions for orthophosphate stock standard.

Section 7.10-7.12: Updated holding time to two months; these standards have shown to be stable for this amount of time.

Section 7.13: Updated preparation instructions for Aquakem cleaning solution.

Section 8.1: Removed two sub-sections that repeated information already present.

Section 8.2: Removed two sub-sections that repeated information already present.

Section 9.2.5: Updated when MDLs need to be re-evaluated.

Section 9.3.4: Edited information regarding control charts; merged section 9.3.6 (reagent blank control chart) into section 9.3.4.

Section 9.3.5: Edited section to include ICV details.

Section 9.4.2: Added percent recovery acceptance range for spiked samples.

Section 10.1: Updated details on the number of calibration points; previously only listed six points for all calibrations.

Section 10.2: Changed accepted r value to 0.995 from 0.980.

Section 11.5: Added details on cuvette waste box.

Section 11.7: Added details on “perform water washes” instruction.

Section 11.8: Added section to describe test wash details.

Section 11.9: Added section on instrument start up.

Section 11.11: Clarified how to complete water blank checks.

Sections 11.12-11.15: Added details on program navigation.

Section 11.18: Replaced “usual ICV” with “recommended ICV”.

Section 11.20: Added details on running samples within the correct calibration range.

Sections 11.21 & 11.23: Added details on program navigation

1 SCOPE and APPLICATION

- 1.1 Total Particulate Phosphorus, Inorganic Particulate Phosphorus, and Phosphorus in algal and sediment samples are determined using this method.
- 1.2 Ammonium molybdate and potassium antimony tartrate react in an acid medium with dilute solutions of phosphorus to form an antimony-phosphomolybdate complex which is reduced to an intensely blue-colored complex by ascorbic acid. Color is proportional to phosphorus concentration. The method is used to analyze all ranges of salinity.
- 1.3 A Method Detection Limit (MDL) of 0.0021 mg P/L for Total Particulate Phosphorus was determined using the Student's *t* value (3.14) times the standard deviation of seven replicates. If more than seven replicates are used to determine the MDL, refer to the Student's *t* test table for the appropriate n-1 value.
- 1.4 A Method Detection Limit (MDL) of 0.0021 mg P/L for Particulate Inorganic Phosphorus was determined using the Student's *t* value (3.14) times the standard deviation of seven replicates. If more than seven replicates are used to determine the MDL, refer to the Student's *t* test table for the appropriate n-1 value.
- 1.5 A Method Detection Limit (MDL) of 0.009%P for Total Particulate Phosphorus sediment was determined using the Student's *t* value (3.14) times the standard deviation of seven replicates. If more than seven replicates are used to determine the MDL, refer to the Student's *t* test table for the appropriate n-1 value.
- 1.6 The Quantitation Limit for TPP was set at 0.0063 mg P /L.
- 1.7 The Quantitation Limit for PIP was set at 0.0063 mg P /L.
- 1.8 The method is suitable for P concentrations 0.0021 to 3.72 mg PO₄-P/L.
- 1.9 This procedure should be used by analysts experienced in the theory and application of combusted, extractive particulate nutrient analysis. Three months experience with an analyst, experienced in the analysis of combusted, extractive, particulate phosphorus analysis, is required.
- 1.10 This method can be used for all programs that require analysis of particulate phosphorus.
- 1.11 The colorimetric portion of the procedure references EPA Method 365.1 (1979).

2 SUMMARY

- 2.1 Samples for the measurement of Total Particulate Phosphorus are combusted, then extracted in an acidic medium.
- 2.2 Samples for the measurement of Particulate Inorganic Phosphorus are extracted in an acidic medium.
- 2.3 Extracted samples are mixed with a sulfuric acid-antimony-molybdate solution, and subsequently with an ascorbic acid solution, yielding an intense blue color suitable for photometric measurement.

3 DEFINITIONS

- 3.1 Acceptance Criteria – Specified limits placed on characteristics of an item, process, or service defined in a requirement document. (ASQC)
- 3.2 Accuracy – The degree of agreement between an observed value and an accepted reference value. Accuracy includes a combination of random error (precision) and systematic error (bias) components which are due to sampling and analytical operations; a data quality indicator. (QAMS)
- 3.3 Aliquot – A discrete, measured, representative portion of a sample taken for analysis. (EPA QAD Glossary)
- 3.4 Analytical Range – 0.0021 to 3.72 mg P/L in extract. The overall analytical range of extracted samples is comprised of three distinct, yet overlapping concentration ranges. A separate calibration is performed for each range. These ranges include 0.05723 to 0.744 mg P/L, 0.1488 to 1.488 mg P/L and 0.53143 to 3.72 mg P/L. Three sub-ranges are utilized so that extracted samples can be analyzed on the most appropriate scale possible. Final concentration of particulate phosphorus in the sample is dependent on volume filtered.
- 3.5 Batch – An analytical batch is composed of prepared environmental samples (extracts, digestates, concentrates) and/or those samples not requiring preparation, which are analyzed together as a group using the same calibration curve or factor with the same process and personnel using the same lot(s) of reagents. A batch can include samples originating from various environmental matrices and can exceed 20 samples. (NELAC/EPA)
- 3.6 Blank- A sample that has not been exposed to the analyzed sample stream in order to monitor contamination during sampling, transport, storage or analysis. The blank is subjected to the usual analytical and measurement process to establish a zero baseline or background value and is sometimes used to adjust or correct routine analytical results. (ASQC)
- 3.7 Calibrate- To determine, by measurement or comparison with a standard, the correct value of each scale reading on a device. The levels of the applied calibration standard should bracket the range of planned or expected sample measurements. (NELAC)
- 3.8 Calibration – The set of operations which establish, under specified conditions, the relationship between values indicated by a measuring device. The levels of the applied calibration standard should bracket the range of planned or expected sample measurements. (NELAC)
- 3.9 Calibration Blank – A volume of reagent water fortified with the same matrix as the calibration standards, without analyte added.
- 3.10 Calibration Curve – The graphical relationship between known values, such as concentrations, or a series of calibration standards and their analytical response. (NELAC)
- 3.11 Calibration Method – A defined technical procedure for performing a calibration. (NELAC)
- 3.12 Calibration Standard – A substance or reference material used to calibrate an instrument. (QAMS)

- 3.12.1 Initial Calibration Standard (STD) – A series of standard solutions used to initially establish instrument calibration responses and develop calibration curves for individual target analytes.
- 3.12.2 Initial Calibration Verification (ICV) – An individual standard, distinct from the Initial Calibration Standards (STD), analyzed initially, prior to any sample analysis, which verifies acceptability of the calibration curve or previously established calibration curve.
- 3.12.3 Continuing Calibration Verification (CCV) – An individual standard, distinct from the Initial Calibration Standards (STD), analyzed after every 18-23 field sample analyses.
- 3.13 Certified Reference Material – A reference material one or more of whose property values are certified by a technically valid procedure, accompanied by or traceable to a certificate or other documentation which is issued by a certifying body. (ISO 17025)
- 3.14 Corrective Action – Action taken to eliminate the causes of an existing nonconformity, defect or other undesirable situation in order to prevent recurrence. (ISO 8402)
- 3.15 Deficiency – An unauthorized deviation from acceptable procedures or practices. (ASQC)
- 3.16 Demonstration of Capability – A procedure to establish the ability of the analyst to generate acceptable accuracy. (NELAC)
- 3.17 Detection Limit – The lowest concentration or amount of the target analyte that can be determined to be different from zero by a single measurement at a stated degree of confidence.
- 3.18 Duplicate Analysis – The analyses of measurements of the variable of interest performed identically on two sub samples (aliquots) of the same sample. The results from duplicate analyses are used to evaluate analytical or measurement precision but not the precision of sampling, preservation or storage external to the laboratory. (EPA-QAD)
- 3.19 External Standard (ES) – A pure analyte (Potassium dihydrogen phosphate (KH_2PO_4)) that is measured in an experiment separate from the experiment used to measure the analyte(s) in the sample. The signal observed for a known quantity of the pure external standard is used to calibrate the instrument response for the corresponding analyte(s). The instrument response is used to calculate the concentrations of the analyte(s) in the unknown sample.
- 3.20 Field Duplicates (FD1 and FD2) – Two separate samples collected at the same time and place under identical circumstances and treated exactly the same throughout field and laboratory procedures. Analyses of FD1 and FD2 provide a measure of the precision associated with sample collection, preservation and storage, as well as with laboratory procedures.
- 3.21 Holding time – The maximum time that samples may be held prior to analysis and still be considered valid. (40 CFR Part 136) The time elapsed from the time of sampling to the time of extraction or analysis, as appropriate.

- 3.22 Laboratory Duplicates (LD1 and LD2) – Two aliquots of the same sample taken in the laboratory and analyzed separately with identical procedures. Analyses of LD1 and LD2 indicate precision associated with laboratory procedures, but not with sample collection, preservation, or storage procedures.
- 3.23 Laboratory Reagent Blank (LRB) – A blank matrix (i.e., 1 N HCl) that is treated exactly as a sample including exposure to all glassware, equipment, solvents, and reagents that are used with other samples. The LRB is used to determine if method analytes or other interferences are present in the laboratory environment, the reagents, or the instrument.
- 3.24 Laboratory Control Sample (LCS) – A sample matrix, free from the analytes of interest, spiked with verified known amounts of analytes from a source independent of the calibration standard or a material containing known and verified amounts of analytes. The LCS is generally used to establish intra-laboratory or analyst-specific precision and bias or to assess the performance of all or a portion of the measurement system. (NELAC)
- 3.25 Limit of Detection (LOD) – The lowest concentration level that can be determined by a single analysis and with a defined level of confidence to be statistically different from a blank. This is also referred to as the MDL. (ACS)
- 3.26 Limit of Quantitation (LOQ) – The minimum levels, concentrations, or quantities of a target variable (target analyte) that can be reported with a specified degree of confidence. The LOQ is set at 3 to 10 times the LOD, depending on the degree of confidence desired. This is also referred to as the Quantitation Limit.
- 3.27 Linear Dynamic Range (LDR) – The absolute quantity over which the instrument response to an analyte is linear. This specification is also referred to as the Linear Calibration Range (LCR).
- 3.28 Material Safety Data Sheets (MSDS) – Written information provided by vendors concerning a chemical's toxicity, health hazards, physical properties, fire, and reactivity data including storage, spill, and handling precautions.
- 3.29 May – Denotes permitted action, but not required action. (NELAC)
- 3.30 Method Detection Limit (MDL) – The minimum concentration of an analyte that can be identified, measured, and reported with 99% confidence that the analyte concentration is greater than zero (Standard Methods).
- 3.31 Must – Denotes a requirement that must be met. (Random House College Dictionary)
- 3.32 Photometer – measures the absorbance of the solution in the cell in a multicell cuvette. Light passes from the lamp through the condensing lenses to the interference filter. The plane surface of the first condensing lens is coated with a material which reflects heat and infrared light. The filters are mounted on a filter wheel. There are 15 positions for filters. Each filter corresponds to a wavelength of interest. The 880 nm filter is specified by the test definition for particulate phosphorus. After passing through the filter the light is converted into a stream of light pulses by a chopper. Then the light is directed via a quartz fiber through a focusing lens and a slit to the beam divider. The beam divider divides the light into two parts. A specified portion is reflected to the reference detector, which monitors the light level fluctuations. The remaining major

- portion of the light beam goes through the liquid in the cell to the signal detector, which measures the amount of light absorbed.
- 3.33 Precision – The degree to which a set of observations or measurements of the same property, obtained under similar conditions, conform to themselves; a data quality indicator. Precision is usually expressed as standard deviation, variance or range, in either absolute or relative terms. (NELAC)
- 3.34 Preservation – Refrigeration, freezing, and/or reagents added at the time of sample collection (or later) to maintain the chemical and or biological integrity of the sample.
- 3.35 Quality Control Sample (QCS) – A sample of analyte of known and certified concentration. The QCS is obtained from a source external to the laboratory and different from the source of calibration standards. It is used to check laboratory performance with externally prepared test materials. Also referred to as CRM.
- 3.36 Run Cycle – Typically a day of operation – the entire analytical sequence from sampling the first standard to the last sample of the day.
- 3.37 Sample Segment – Bar-coded metal tray that holds up to fourteen four milliliter auto analyzer vials containing samples or standards. The user identifies each vial in the operating software.
- 3.38 Sample Segment Holder – An automated, temperature controlled carousel that contains up to six sample segments. This carousel spins in clockwise or counterclockwise manner to move the sample segments into position for analysis. This carousel format allows for continuous processing.
- 3.39 Sensitivity – The capability of a test method or instrument to discriminate between measurement responses representing different levels (concentrations) of a variable of interest.
- 3.40 Shall – Denotes a requirement that is mandatory whenever the criterion for conformance with the specification requires that there be no deviation. (ANSI)
- 3.41 Should – Denotes a guideline or recommendation whenever noncompliance with the specification is permissible. (ANSI)
- 3.42 Standard Reference Material (SRM) – Material which has been certified for specific analytes by a variety of analytical techniques and/or by numerous laboratories using similar analytical techniques. These may consist of pure chemicals, buffers, or compositional standards. The materials are used as an indication of the accuracy of a specific analytical technique. Also referred to as CRM.
- 3.43 Test Definition – A photometric test consisting of a user defined testing sequence, reagent additions, calibration standards, incubations and absorption results.
- 3.44 Test Flow – Functions to define the parameter for reagent and sample dispensing, dilution, incubation and measurement.

4 INTERFERENCES





- 4.1 Suspended matter in the sample will scatter light as it passes through the cuvette to the detector. High blank responses will result. The identified sample will be reanalyzed.
- 4.2 Blemishes in the cuvette, as result of the manufacturing process, will result in high blank responses. The identified sample will be reanalyzed.
- 4.3 Silicon (Si) at analysis temperature $>40^{\circ}\text{C}$ and/or $<2.2\text{ N}$ Sulfuric Acid in the Triple Reagent solution causes interference in the concentration range $> 0.05\text{ mg/mL}$ Si in the extract. High silica concentrations cause positive interference. These conditions are avoided by maintaining an acid concentration of 2.45 N Sulfuric Acid in the reagents and analysis at 37°C .



5 SAFETY

Safety precautions must be taken when handling reagents, samples and equipment in the laboratory. Protective clothing including lab coats, safety glasses and enclosed shoes must be worn. In certain situations, it will be necessary to also use gloves and/or a face shield. If solutions come in contact with eyes, flush with water continuously for 15 minutes. If solutions come in contact with skin, wash thoroughly with soap and water. Contact Solomons Rescue Squad (911) if emergency treatment is needed. Inform the CBL Associate Director of Facilities and Maintenance of the incident and if additional treatment is required.

- 5.1 The toxicity or carcinogenicity of each reagent used in this procedure may not have been fully established. Each chemical should be regarded as a potential health hazard and exposure should be as low as reasonably achievable. Cautions are included for known hazardous materials and procedures.
- 5.2 Do not wear jewelry when troubleshooting electrical components. Even low voltage points are dangerous and can injure if allowed to short circuit.
- 5.3 The following hazard classifications are listed for the chemicals used in this procedure. Detailed information is provided on Material Safety Data Sheets (MSDS).

Table 1

Chemical	Health Hazard	Fire Hazard	Instability Hazard	Specific Hazard	
Hydrochloric Acid	3	0	1	ACID, COR	
Sulfuric acid	4	0	2	ACID, COR	
Ammonium molybdate	4	0	1	Irritant	 
Potassium antimonyl tartrate	2	0	0		

hemihydrate					
Ascorbic Acid	1	0	0	ACID	
Potassium dihydrogen phosphate	2	0	0		
Chloroform	3	0	0		
Clorox	3	0	0		

On a scale of 0 to 4 the substance is rated on four hazard categories: health, flammability, reactivity, and contact. (0 is non-hazardous and 4 is extremely hazardous)

HAZARD RATING

Health Hazard - Blue: 4 – deadly, 3 – extreme danger, 2 – hazardous, 1 – slightly hazardous, 0 – normal material

Fire Hazard - Red: Flash Points: 4 – below 73° F, 3 – below 100° F, 2 – below 200° F, 1 – above 200° F, 0 – will not burn

Instability Hazard - Yellow: 4 – may detonate, 3 – Shock and heat may detonate, 2 – violent chemical change, 1 – unstable if heated, 0 - stable

Specific Hazard - White: Acid = ACID, Alkali = ALK, Corrosive = COR, Oxidizer = OXY

6 EQUIPMENT AND SUPPLIES

- 6.1 Filtering apparatus
- 6.2 Glass fiber filters. This laboratory uses Whatman GF/F (47 mm, 0.7 µm pore size) filter pads for water samples.
- 6.3 Foil pouches, labeled with sample identification and volume filtered.
- 6.4 Flat-bladed forceps.
- 6.5 Freezer, capable of maintaining $-20^{\circ} \pm 5^{\circ}\text{C}$.
- 6.6 Drying oven. This laboratory uses Lindberg/Blue M Drying Oven
- 6.7 Crucibles and lids for combusting filter pads; a separate set of crucibles and lids for combusting sediments and algae
- 6.8 Muffle furnace. This laboratory uses a ThermoLyne F30428 combustion oven set at 500°C to obtain a true combustion temperature of 550°C .
- 6.9 Analytical balance accurate to 0.0001 g for weighing sediment and algae
- 6.10 AutoAnalyzer vial containers (sample cups) and racks to hold them
- 6.11 Lab ware: 50 mL plastic centrifuge tubes with screw caps
- 6.12 1 digital timer
- 6.13 1 re-pipettor
- 6.14 Lab ware – All reusable lab ware (glass, Teflon, plastic, etc) should be sufficiently clean for the task objectives. This laboratory cleans all lab ware

related to this method with a 10% HCl (v/v) acid rinse. This laboratory cleans all lab ware that has held solutions containing ammonium molybdate with 10% NaOH (w/v) rinse.

- 6.15 Aquakem 250 multi-wavelength automated discrete photometric analyzer. Aquakem 250 control software operates on a computer running Microsoft Windows NT, XP or 7 operating system.

7 REAGENTS AND STANDARDS

- 7.1 Purity of Water – Unless otherwise indicated, references to water shall be understood to mean reagent water conforming to Specification D 1193, Type I. Freshly prepared water should be used for making the standards intended for calibration. The detection limits of this method will be limited by the purity of the water and reagents used to make the standards.
- 7.2 Purity of Reagents – Reagent grade chemicals shall be used in all tests. Unless otherwise indicated, it is intended that all reagents shall conform to specifications of the Committee on Analytical Reagents of the American Chemical Society, where such specifications are available. Other grades may be used, provided it is first ascertained that the reagent is of sufficiently high purity to permit its use without compromising the accuracy of the determination.

7.3 1 N Hydrochloric acid

Hydrochloric acid (concentrated) 172mL

In a 2000mL volumetric flask add approximately 1600 mL reagent water. Add 172 mL concentrated HCl to the reagent water, let cool, and bring to volume. Write name of preparer, preparation date, reagent manufacturer, manufacturer's lot number in the Analytical Reagent log book. Store the flask at room temperature. Reagent is stable for one year.

7.4 9.8 N Sulfuric acid

Sulfuric acid (concentrated) 54.4 mL

In a 200 mL volumetric flask add approximately 120 mL reagent water. Add 54.4 mL H₂SO₄ to the reagent water, let cool, and bring to volume. Write name of preparer, preparation date, reagent manufacturer, manufacturer's lot number in the Analytical Reagent log book. Store the flask at room temperature. Reagent is stable for one year.

7.5 Ammonium molybdate solution

Ammonium molybdate 8.0 g

In a 100 mL plastic volumetric flask, dissolve with immediate inversion 8.0 g Ammonium molybdate in approximately 90 mL reagent water. Bring flask to volume. Store the flask in the dark at room temperature. Write name of preparer, preparation date, reagent manufacturer, manufacturer's lot number in the Analytical Reagent log book. Reagent is stable for one month. Discard if white precipitate appears in flask or on threads of cap.

7.6 Potassium antimonyl tartrate solution

Potassium antimonyl tartrate 0.6 g

In a 100 mL plastic volumetric flask dissolve 0.6 g Potassium antimonyl tartrate hemihydrate in approximately 90 mL reagent water. Bring flask to volume. Store the flask at room temperature. Write name of preparer, preparation date, reagent manufacturer, manufacturer's lot number in the Analytical Reagent log book. Reagent is stable for one year.

7.7 Ascorbic acid solution

Ascorbic acid	3.6 g
---------------	-------

In a 100 mL plastic volumetric flask dissolve 3.6g Ascorbic acid in approximately 90 mL reagent water. Bring flask to volume. Store the flask in the refrigerator. Write name of preparer, preparation date, reagent manufacturer, manufacturer's lot number in the Analytical Reagent log book. Reagent is stable for two months.

7.8 Triple Reagent -

9.8 N Sulfuric acid	40 mL
Ammonium molybdate solution	12 mL
Potassium antimonyl tartrate solution	4.0 mL

Add 40 mL 9.8 N Sulfuric acid to a 60 mL reagent container. Carefully add 12 mL Ammonium molybdate solution to the reagent container. Carefully add 4.0 mL Potassium antimonyl tartrate solution to the reagent container. Cap. Invert six times to mix. Write name of preparer, preparation date, constituent solutions' preparation dates in the Analytical Reagent log book. Reagent is stable for two weeks.

7.9 Orthophosphate Stock Standard, 12,000 μM –

Potassium dihydrogen phosphate (KH_2PO_4), primary standard grade, dried at 45°C	0.816 g
--	---------

In a 500 mL volumetric flask, dissolve 0.816 g of potassium dihydrogen phosphate in approximately 400 mL reagent water. Bring flask to volume with reagent water (1 mL contains 12 $\mu\text{moles P}$). Add 1 mL chloroform as a preservative. Transfer to a brown bottle and store in refrigerator. Write name of preparer, preparation date, standard manufacturer, manufacturer lot number in the Analytical Standard log book. Make fresh every 6 months.

7.10 Working Low Orthophosphate in HCl Standard –

Stock Orthophosphate standard	0.20 mL
-------------------------------	---------

In a 100 mL volumetric flask, dilute 0.20 mL of Stock Orthophosphate Standard to volume with 1 N HCl to yield a concentration of 24 $\mu\text{M PO}_4\text{-P/L}$ (0.744mg P/L). Write name of preparer, preparation date, Stock Standard preparation date in the Analytical Standard log book. Make fresh every two months.

7.11 Working Mid-Range Orthophosphate in HCl Standard –

Stock Orthophosphate Standard	0.40 mL
-------------------------------	---------

In a 100 mL volumetric flask, dilute 0.40 mL of Stock Orthophosphate Standard to volume with 1 N HCl to yield a concentration of 48 $\mu\text{M PO}_4\text{-P/L}$ (1.488 mg P/L). Write name of preparer, preparation date, Stock Orthophosphate Standard preparation date in the Analytical Standard log book. Make fresh every two months.

- 7.12 Working High Orthophosphate in HCl Standard –
- | | |
|-------------------------------|---------|
| Stock Orthophosphate Standard | 1.00 mL |
|-------------------------------|---------|
- In a 100 mL volumetric flask, dilute 1.00 mL of Stock Orthophosphate Standard to volume with 1 N HCl to yield a concentration of 120 μM $\text{PO}_4\text{-P/L}$ (3.72 mg P/L). Write name of preparer, preparation date, Stock Orthophosphate Standard preparation date in the Analytical Standard log book. Make fresh every two months.
- 7.13 Aquakem Cleaning Solution –
- | | |
|--------|---------|
| Clorox | 55.0 mL |
|--------|---------|
- In a 100 mL volumetric flask, dilute 55.0 mL of Clorox to volume with 45 mL reagent water to yield a concentration of 55% Clorox. Write name of preparer, preparation date, reagent manufacturer, manufacturer lot number in the Analytical Reagent log book. Reagent is stable for six months.

8 SAMPLE COLLECTION, PRESERVATION, AND STORAGE

- 8.1 Total Particulate Phosphorus Water Samples
- 8.1.1 Water samples for total particulate phosphorus are filtered. If filtering is delayed more than one hour, the water samples are iced in a cooler or refrigerated until filtered.
- 8.1.2 For each sample, a recorded volume of water is filtered through a 47 mm Whatman GF/F filter pad that has been pre-combusted at 500°C for 90 minutes. After filtering, the pad is folded in half using forceps. This folding maintains the integrity of the particulate matter concentrated on the pad.
- 8.1.3 The pad containing the sample is placed in a labeled foil pouch. The label identifies the sample, sampling date and volume filtered.
- 8.1.4 Freeze samples at $-20^\circ \pm 5^\circ \text{C}$.
- 8.2 Particulate Inorganic Phosphorus Water Samples
- 8.2.1 Water samples for total particulate inorganic phosphorus are filtered. If filtering is delayed more than one hour, the water samples are iced in a cooler or refrigerated until filtered.
- 8.2.2 For each sample, a recorded volume of water is filtered through a 47 mm Whatman GF/F filter pad that has been pre-combusted at 500°C for 90 minutes. After filtering, the pad is folded in half using forceps. This folding maintains the integrity of the particulate matter concentrated on the pad.
- 8.2.3 The pad containing the sample is placed in a labeled foil pouch. The label identifies the sample, sampling date and volume filtered.
- 8.2.4 Freeze samples at $-20^\circ \pm 5^\circ \text{C}$.
- 8.3 Algae and sediment samples
- 8.3.1 Samples are dried overnight at 50°C, then ground to uniform powdery consistency and placed in labeled, capped vials.

- 8.4 Frozen samples may be stored up to 28 days. It has been shown that frozen QCS samples up to a year old still fall well within the control limits.

9 QUALITY CONTROL

- 9.1 The laboratory is required to operate a formal quality control (QC) program. The minimum requirements of this program consist of an initial demonstration of laboratory capability and the continued analysis of laboratory instrument blanks and calibration standard material, analyzed as samples, as a continuing check on performance. The laboratory is required to maintain performance records that define the quality of data generated.
- 9.2 Initial Demonstration of Performance
- 9.2.1 The initial demonstration of capability (IDOC) – is used to characterize instrument performance (MDLs) and laboratory performance (analysis of QC samples) prior to the analyses conducted by this procedure.
- 9.2.2 Linear Dynamic Range – LDR (Linear Calibration Range) should be established for phosphorus using appropriate seven point calibration curve.
- 9.2.3 Quality Control Sample (QCS/SRM) – When using this procedure, a quality control sample is required to be analyzed at the beginning and end of the run, to verify data quality and acceptable instrument performance. If the determined concentrations are not within $\pm 3s$ of the certified values, performance of the determinative step of the method is unacceptable. The source of the problem must be identified and corrected before either proceeding with the initial determination of MDLs or continuing with analyses.
- 9.2.4 Method Detection Limits (MDLs) – MDLs should be established for particulate phosphorus using a low level natural water sample, typically three to five times higher than the estimated MDL. The same procedure should be followed for sediments or other weighed samples. To determine the MDL values, analyze seven replicates and process through the entire analytical procedure. Perform all calculations defined in the procedure (Section 12) and report the concentration values in the appropriate units. Calculate the MDL as follows:
- $$\text{MDL} = S t_{(n-1, 1-\alpha=0.99)}$$
- Where,
- S = Standard deviation of the replicate analyses.
 - n=number of replicates
 - $t_{(n-1, 1-\alpha=0.99)}$ = Student's *t* value for the 99% confidence level with n-1 degrees of freedom ($t=3.14$ for 7 replicates.)
- 9.2.5 MDLs shall be determined yearly and whenever there is a significant change in instrument response or a significant change in instrument configuration.

9.3 Assessing Laboratory Performance

- 9.3.1 Laboratory Reagent Blank (LRB) – The laboratory must analyze at least one LRB with each batch of samples. The LRB consists of 1 N HCl treated the same as the samples. Analyte found in LRB indicates possible reagent or laboratory environment contamination. LRB data are used to assess and correct contamination from the laboratory environment.
- 9.3.2 Quality Control Sample (QCS)/ Standard Reference Material (SRM) – When using this procedure, a quality control sample is required to be analyzed at the beginning of the run and end of the run, to verify data quality and acceptable instrument performance. If the determined concentrations are not within $\pm 3s$ of the certified values, performance of the determinative step of the method is unacceptable. The source of the problem must be identified and corrected before either proceeding with the initial determination of MDLs or continuing with the analyses. The results of these QCS/SRM samples shall be used to determine batch acceptance.
- 9.3.3 The QCS are obtained from a source external to the laboratory and different from the source of calibration standards.
- 9.3.4 Control Charts – The Accuracy Control Chart for QCS/SRM and Reagent Blank samples are constructed from the average and standard deviation of sample measurements recorded annually. The accuracy chart includes upper and lower warning levels ($WL=\pm 2s$) and upper and lower control levels ($CL=\pm 3s$). The standard deviation (s) is specified relative to statistical confidence levels of 95% for WLs and 99% for CLs. Enter QCS/SRM and Reagent Blank results on the chart each time the samples are analyzed.
- 9.3.5 Initial and Continuing Calibration Verification (ICV/CCV) – Immediately following calibration (ICV) and following every 18-23 samples (CCV), one calibration verification of 18 $\mu\text{M PO}_4\text{-P/L}$ (0.558 mg P/L) PPLOWCBL, 36 $\mu\text{M PO}_4\text{-P/L}$ (1.116 mg P/L) PPCBL, 96 $\mu\text{M PO}_4\text{-P/L}$ (2.976 mg P/L) PPHIGH is analyzed to assess instrument performance. The ICV/CCVs are made from the same material as calibration standards (KH_2PO_4), and are to be within the expected value $\pm 3s$. Failure to meet the criteria requires correcting the problem, including reanalysis of any affected samples. If not enough sample exists, the data must be qualified if reported.

9.4 Assessing Analyte Recovery - Percent Recovery

- 9.4.1 Analyte recovery is assessed through percent recoveries of laboratory spikes of samples.
- 9.4.2 Percent Recovery = (Actual value/expected value) X 100. Percent recovery for each spiked sample should fall within 80-120%.

9.5 Assessing Analyte Precision – Relative Percent Difference

- 9.5.1 Analyte replication is assessed through duplicate analyses of samples – Relative Percent Difference (RPD).

9.5.2 $RPD = \frac{\text{Laboratory Duplicate Result 1} - \text{Laboratory Duplicate Result 2}}{[(\text{Laboratory Duplicate Result 1} + \text{Laboratory Duplicate Result 2})/2]} \times 100$.

9.6 Corrective Actions for Out of Control Data

9.6.1 Control limit – If one measurement exceeds Accuracy Control Chart CL, repeat the analysis immediately. If the repeat measurement is within the CL, continue analyses; if it exceeds the CL, discontinue analyses and correct the problem.

9.6.2 Warning limit – If two out of three successive points exceed Accuracy Control Chart WL, analyze another sample. If the next point is within WL, continue analyses; if the next point exceeds the WL, evaluate potential bias and correct the problem.

9.6.3 Trending – If seven successive Accuracy Control Chart measurements are on the same side of the central line, discontinue analyses and correct the problem.

9.6.4 When external QCS samples are out of control, correct the problem. Reanalyze the samples analyzed between the last in-control measurement and the out-of-control one.

9.6.5 When external CCV samples are out of control, correct the problem. Reanalyze the samples analyzed between the last in-control measurement and the out-of-control one.

9.7 General Operation - To assure optimal operation and analytical results, the Reagent Blank and CCV are tracked daily in the raw data file, copied to Reagent Blank and CCV Control Charts.

Table 2

QC Indicator	Acceptance/ Action Limits	Action	Frequency (Batch)
Correlation Coefficient	≥ 0.995	If <0.995, evaluate data points of the calibration curve. If any data point is outside established limits, reject as outlier.	1 per batch if acceptable.
Quality Control Sample (QCS)/ Certified Reference Material (CRM)	± 10%	If QCS value is outside ± 10% of the target value reject the run, correct the problem and rerun samples.	Beginning of run and at end of run.
Initial Calibration Verification (ICV)	± 10%	Recalibrate if outside acceptance limits.	Beginning of run following standard curve.
Continuing Calibration Verification (CCV)	± 10%	If outside 10%, correct the problem. Rerun all samples following the last in-control CCV.	After every 18-23 samples.

Method Blank/Laboratory Reagent Blank (LRB)	≤ Method Quantitation Limit	If the LRB exceeds the quantitation limit, results are suspect. Rerun the LRB. If the concentration still exceeds the quantitation limit, reject or qualify the data, or raise the quantitation limit.	Following the ICV and after every 18-23 samples following the CCV.
Laboratory Fortified Sample Matrix Spike	± 20%	If the recovery of any analyte falls outside the designated acceptance limits and the QCS is in control, the recovery problem is judged matrix induced. Repeat the LFMS and if the sample results are again outside the acceptable recovery range, the sample should be reported with a “matrix induced bias” qualifier.	1/10 (spike OR duplicate)
Laboratory Duplicate	± 20%	If the RPD fails to meet the acceptance limits, the samples should be reanalyzed. If the RPD again fails to meet the acceptance limits, the sample must be reported with a qualifier identifying the sample analysis result as not having acceptable RPD for duplicate analysis.	1/10 (spike OR duplicate)

10 CALIBRATION AND STANDARDIZATION

10.1 Calibration – Daily calibration must be performed before sample analysis may begin. Six or seven point calibrations are used with three sub-calibrations that cover the analytical range. Three working orthophosphate standards in HCl are used to produce the calibrators for each set of three calibration curves. The instrument performs serial dilutions of working standards to produce the calibrators defined for each curve. The following outlines the preparation of the working standards and the following table describes the subsequent serial dilutions the instrument performs to make each standard for each of the three calibration curves.

Orthophosphate Working Standards:

PPLOWCBL

Working Standard 0.744 mg P/L (0.20 mL stock to 100 mL)

Working CCV	0.558 mg P/L	(0.15 mL stock to 100 mL)
PPCBL		
Working Standard	1.488 mg P/L	(0.4 mL stock to 100 mL)
Working CCV	1.116 mg P/L	(0.3 mL stock to 100 mL)
PPHIGH		
Working Standard	3.720 mg P/L	(1.0 mL stock to 100 mL)
Working CCV	2.976 mg P/L	(0.8 mL stock to 100 mL)

Table 3. Orthophosphate Calibrators:

Test Name	Working Standard	Dilution Factor	Concentration mg P/L
PPLOWCBL	0.744 mg P/L	1+12	0.0572
	0.744 mg P/L	1+9	0.0744
	0.744 mg P/L	1+6	0.1063
	0.744 mg P/L	1+3	0.186
	0.744 mg P/L	1+2	0.248
	0.744 mg P/L	1+1	0.372
	0.744 mg P/L	1+0	0.744
PPCBL	1.488 mg P/L	1+9	0.1488
	1.488 mg P/L	1+4	0.2976
	1.488 mg P/L	1+3	0.372
	1.488 mg P/L	1+2	0.496
	1.488 mg P/L	1+1	0.744
	1.488 mg P/L	1+0	1.488
PPHIGH	3.72 mg P/L	1+6	0.531
	3.72 mg P/L	1+4	0.744
	3.72 mg P/L	1+3	0.93
	3.72 mg P/L	1+2	1.24
	3.72 mg P/L	1+1	1.86
	3.72 mg P/L	1+0	3.72

10.2 The instrument software prepares a standard curve for each set of calibrators. A graph plotting measured absorbance against standard concentration is presented for review and approval. If acceptance criteria are not met the entire curve can be reanalyzed or individual standards can be reanalyzed. One standard value (original or reanalyzed) for each and every standard is incorporated in the curve. The coefficient of determination (Pearson's r value) for the calibration curve as well as the calculated concentration of each calibrator is reviewed. The calculated value of each calibrator must be within ten percent of the expected

value. The coefficient of determination (Pearson's r value) for the calibration curve must be greater than 0.995.

11 PROCEDURE – DAILY OPERATIONS QUALITY CONTROL

11.1 Total Particulate Phosphorus Combustion and Extraction

- 11.1.1 Remove samples on pre-combusted filter pads from freezer. Open aluminum foil pouches containing the samples slightly to allow air circulation and dry in drying oven overnight. Samples for PP only are dried at 45°C. Samples that are also analyzed for TSS have been previously dried at 103-105°C in accordance with the TSS method.
- 11.1.2 Place dried filter pads in labeled Coors crucibles, recording crucible number, sample identification number and volume filtered. Cover with lids. Combust at setting of 500°C for 90 minutes. For this laboratory's muffle furnace, this setting has been determined to produce 550 °C.
- 11.1.3 Cool to room temperature. Transfer combusted pads to numbered 50 mL plastic screw cap centrifuge tubes whose numbers correspond to Coors crucible numbers.
- 11.1.4 Using re-pipettor, add 10 mL 1 N HCl to each centrifuge tube. Screw on cap.
- 11.1.5 After minimum of 24 hours, shake each sample. Wait an additional 24 hours before analyzing.
- 11.1.6 To analyze, transfer an aliquot of each sample to a labeled AutoAnalyzer vial container (sample cup) for analysis that day.

11.2 Particulate Inorganic Phosphorus Extraction

- 11.2.1 Remove samples on pre-combusted filter pads from freezer. Open aluminum foil pouches containing the samples slightly to allow air circulation and dry in drying oven overnight at 45°C.
- 11.2.2 Transfer dried pads to numbered 50 mL plastic screw cap centrifuge tubes, recording sample identification number and volume filtered.
- 11.2.3 Using re-pipettor, add 10 mL 1 N HCl to each centrifuge tube. Screw on cap.
- 11.2.4 After a minimum of 24 hours, shake each sample. Wait an additional 24 hours before analyzing.
- 11.2.5 To analyze, transfer an aliquot of each sample to a labeled AutoAnalyzer vial container (sample cup) for analysis that day.

11.3 Total Algal or Sediment Phosphorus Combustion and Extraction

- 11.3.1 Place vials containing ground algae or sediment samples in drying oven at 50°C overnight with their screw caps loosened slightly.
- 11.3.2 Remove from drying oven, tighten screw caps.
- 11.3.3 After samples reach room temperature, weigh approximately 15-20 mg of each sample into labeled Coors crucibles, recording crucible number, sample identification number and sample weight. Cover with lids. Combust at setting of 500°C for 90 minutes. For this laboratory's muffle furnace, this setting has been determined to produce 550 °C.

- 11.3.4 Cool to room temperature. Transfer combusted samples to numbered 50 mL plastic screw cap centrifuge tubes whose numbers correspond to Coors crucible numbers. Using re-pipettor, add 10 mL 1 N HCl to each crucible and pour quantitatively into centrifuge tube. Again, using re-pipettor, add 10 mL 1 N HCl to each crucible and pour quantitatively into centrifuge tube. Screw on cap. Sample is in a total of 20 mL 1N HCl.
- 11.3.5 After a minimum of 24 hours, shake each sample. Wait an additional 24 hours before analyzing.
- 11.3.6 To analyze, transfer an aliquot of each sample to a labeled AutoAnalyzer vial container (sample cup) for analysis that day.
- 11.4 Turn on computer. Computer will automatically initiate Konelab software. Once software is running, turn on instrument and allow connection between instrument and computer to complete.
- 11.5 Place cuvette waste box into cuvette waste sliding drawer. Discard any water remaining in the water reservoir from the previous analytical run. Fill the water reservoir with fresh reagent water.
- 11.6 Begin daily bench sheet documentation.
- 11.7 Once water reservoir is full, use instrument software to click More, Instrument Actions, and Perform Water Wash. – complete at least five wash cycles.
- 11.8 After performing water washes, clean the dispensing needle by performing test washes. Click More, Instrument Actions, More, Adjustment Program. Once in the Adjustment Program, click 4-Dispensing Unit, 1-Dispenser, 8-Test Wash. Perform 8 to 10 Test Washes. When complete, press “Q” to quit until you are able to bring up the Main Page.
- 11.9 Perform Start Up operations by clicking Start Up at the bottom of the Main Page.
- 11.10 Gather working standards and reagents from refrigerator during startup. Assess standards and reagents. Remake anything that has exceeded the time over which it is considered stable.
- 11.11 Once startup is complete, check the instrument water blanks by clicking More, Instrument Actions, More, Check Water Blank. If any of the instrument blanks are outside their predefined and software controlled limits, the user will be notified on the main menu page. User takes corrective action to return instrument functions to controlled limits.
- 11.12 Load reagents in specified position in reagent carousel and place in refrigerated reagent compartment. Reagent positions can be found by clicking reagents at the top of the main page.
- 11.13 Load working standards in a sample segment, identify the standards in their positions from the drop down menus at the individual segment positions, and load into instrument. (Click Samples from the top of the Main Page, then click desired segment number.)
- 11.14 Select the methods to be calibrated by clicking Calibr./QC Selection at the bottom of the main page. Select PPLOW, PPCBL and PPHIGH as the three methods to be calibrated then click Calibrate at the bottom of the page. The three methods will now show as pending. Return to the main page.

11.15 Start instrument and calibration by clicking Page Up (or a green button) on the keyboard. See test flow below for stepwise instrument functions for the analysis of standards and samples.

Test Flow – Method of Analysis, Stepwise

- 150 µL reagent water to cuvette with mixing
 - 15 µL sample to cuvette with mixing
 - Blank response measurement at 880 nm
 - 14 µL Triple Reagent to cuvette with mixing
 - 7 µL Ascorbic Acid Reagent to cuvette with mixing
 - Incubation, 600 seconds, 37°C
 - End point absorbance measurement, 880 nm
 - Software processes absorbance value, blank response value and uses calibration curve to calculate analyte concentration (mg P/L as PO₄)
 - User is notified if any measured values used to calculate final concentration are outside preset limits. If so, analyst has options to accept result, rerun the sample or rerun the sample diluted to a user or software specified factor.
 - User is notified of each blank response value. Blank response >0.001 absorbance units indicates a scratched cuvette or turbid sample. If the blank response value exceeds 0.001 absorbance units, the analyst specifies that the sample is reanalyzed. If the blank response value of the reanalyzed sample is <0.001 absorbance units, the reanalyzed result is accepted. If the same concentration and blank response value >0.001 absorbance units is again obtained, the results are accepted.
- 11.16 Organize samples, reagent blanks, filter blanks, check standards and all quality control samples while instrument performs calibrations.
- 11.17 As calibration curves are produced by the instrument, review them for acceptability. The instrument software prepares a standard curve for each set of calibrators. A graph plotting measured absorbance against standard concentration is presented for review and approval. If acceptance criteria are not met, either the entire curve shall be reanalyzed or individual standards shall be reanalyzed, depending on the violation. One standard value (original or reanalyzed) for each and every calibrator is incorporated in the curve.
- 11.18 Once calibration curves are accepted, samples are loaded into the sample segments and loaded into the instrument for analysis. After the Reagent Blank, the first sample analyzed should be an ICV (initial calibration verification) sample. There should be one ICV sample for each calibration curve, of a concentration close to the middle of each range. The following are the recommended ICV samples for each curve: 0.558 mg P/L for PPLOW, 1.116 mg P/L for PPCBL and 2.976 mg P/L for PPHIGH.
- 11.19 Samples are loaded into the segments and analyzed. CCV (Continuing Calibration Verification) samples (one for each of the three calibration ranges) follow every 18-23 samples. Laboratory Reagent Blanks (LRB) are scattered throughout the analytical batch. Standard Reference Material (SRM) samples are analyzed at the beginning and end of the batch. Throughout the analytical batch, samples are chosen as Laboratory Duplicates and Laboratory Spikes to

assess analyte precision and analyte recovery, respectively. The total number of duplicates and spikes performed will be equal to or greater than ten percent of the total number of samples in the analytical batch.

- 11.20 As sample analysis is complete, results must be reviewed and accepted manually. If results fall outside acceptance limits, the sample should be reanalyzed. If sample result exceeds the highest standard of the highest calibration range, the samples can be automatically diluted by the instrument and reanalyzed. If the result is such that it will fall within a higher calibration range, it should be reanalyzed in the higher range. If the result is such that it will fall within a lower calibration range, it should be reanalyzed within the lower range.
- 11.21 Upon completion of all analysis, results are saved to a daily report file. Click Report on the bottom of the Main Page, More, Results To File, and select one row per result. The file is named by the run date. The daily report file for analytical batch of July 1, 2017 would be named 070117. The file is converted to Microsoft Excel for data work up. Remaining samples are discarded.
- 11.22 All reagents are removed from the reagent chamber and returned to the refrigerator. Reagents that have exceeded their stability period are discarded.
- 11.23 Click on Stand By on the bottom of the main page and insert Aquakem Cleaning Solution into the instrument; shut down procedures are initiated. Daily files are cleared from the instrument software by clicking More, Management, Clear Daily Files. The software is exited and the instrument is turned off. The computer is shut down.
- 11.24 The waste is flushed down the drain with copious amounts of tap water. The waste cuvette box is moved to the fume hood and covered.

12 DATA ANALYSIS AND CALCULATIONS

- 12.1 Upon completion of all analysis, results are saved to a daily report file. The file is named by the run date. The daily report file for analytical batch of July 1, 2017 would be named 070117. The file is converted to Microsoft Excel for data work up. The instrument software has calculated final "Raw" sample concentration (uncorrected for sample volume filtered, and uncorrected for filter pad or 1N HCl Blank) in mg P/L from the designated standard curve, and also correcting each concentration for its associated blank response and any user or instrument specified dilution. Dilution by the instrument is noted by software as analysis ensues and documented in the Excel data report file. The analyst examines each row of data. Results are eliminated that are outside the limits of the calibration range, or have an unrepeated blank response measurement greater than 0.001 absorbance units.
- 12.2 Calculate concentration of Total Particulate Phosphorus or Particulate Inorganic Phosphorus on filter pads from "Raw" sample concentration in mg P/L, normalizing for volume filtered and extraction in 10 mL 1 N HCl:

$$\text{mg P/L} = \frac{(\text{"Raw" Sample mg P/L} - \text{Filter Pad Blank mg P/L}) \times 0.01 \text{ L}}{(\text{Volume Filtered mL}/1000 \text{ mL})}$$

- 12.3 Calculate % Phosphorus in Algae or Sediment Samples from "Raw" sample concentration, normalizing for sample weight and extraction in 20 mL 1N HCl:

$$\% \text{ P} = \frac{[(\text{"Raw" Sample mg P/L} - 1 \text{ N H Cl Blank mg P/L}) \times 0.02 \text{ L}] \times 100}{\text{Sample weight in mg}}$$

13 REFERENCES

- 13.1 Aspila, I., H. Agemian and A.S.Y. Chau. 1976. A semi-automated method for the determination of inorganic, organic and total phosphate in sediments. *Analyst* 101: 187-197.
- 13.2 Keefe, C.W. 1994. The contribution of inorganic compounds to the particulate carbon, nitrogen, and phosphorus in suspended matter and surface sediments of Chesapeake Bay. *Estuaries* 17:122-130.
- 13.3 USEPA. 1979. Method No. 365.1 *in* Methods for chemical analysis of water and wastes. United States Environmental Protection Agency, Office of Research and Development. Cincinnati, Ohio. Report No. EPA-600/4-79-020 March 1979. 460pp.
- 13.4 Frank, J. M., C.F. Zimmermann and C. W. Keefe (2006). Comparison of results from Konelab Aquakem 250 and existing nutrient analyzers. UMCES CBL Nutrient Analytical Services Laboratory, Dec. 2006.

UNIVERSITY OF MARYLAND CENTER FOR ENVIRONMENTAL SCIENCE
CHESAPEAKE BIOLOGICAL LABORATORY
NUTRIENT ANALYTICAL SERVICES LABORATORY
146 Williams St., Solomons MD 20688
<http://nasl.cbl.umces.edu/>

**Determination of Total Suspended Solids (TSS) and Total Volatile Solids (TVS) in
Waters of Fresh/Estuarine/Coastal Waters.**

(Reference Method: EPA Method 160.2 and Standard Methods 208 E.)

**Revision 2017-01
Replaces revision 2015.
Effective April 26, 2017**

Revised by: _____ Date: _____

Reviewed by: _____ Date: _____

Laboratory Supervisor: _____ Date: _____

- 1.6 Replaced “conforms to” with references
- 2.1 Removed “to room temperature” twice
- 2.1 Replaced “reached room temperature” with “cooled”
- 3.0 Removed Definitions for Preparation Batch, Calibration Curve, Laboratory Control Sample, Linear Dynamic Range, Run, Run Cycle, Standard Reference Material
- 3.7 changed “it” to “of”
- 3.11 Made definition for Corrective Action
- 3.19 Added “Laboratory interchanges LOD and MDL.”
- 3.20 Added “Also referred to as quantitation limit”
- 3.23 Changed 98% to 99%
- 3.24 Added “(Standard Methods).
- 5.1 Added “Protective clothing including lab coats, safety glasses and enclosed shoes may be worn. In certain situations it may also be necessary to use gloves and goggles. Contact Solomons Rescue Squad (911) if emergency treatment is needed and also inform the Chesapeake Biological Laboratory (CBL) Associate Director of Administration and Facilities Maintenance of the incident. Contact the CBL Associate Director of Administration and Facilities Maintenance if additional treatment is required.”
- 6.2 Added “as”
- 9.2.1 Replaced (DOC) with (iDOC)
- 9.2 Removed “Quality Control Sample (QCS/SRM) – When using this procedure, a quality control sample is required to be analyzed at the beginning and end of the run, to verify data quality and acceptable instrument performance. If the determined concentrations are not within 3s of the certified values, performance of the determinative step of the method is unacceptable. The source of the problem must be identified and corrected before either proceeding with the initial determination of MDLs or continuing with analyses.”
- 9.2.2 Replaced (Section xx) with (Section 11.3); Replaced yearly with annually; Added “or whenever there is a significant change in instrumental configuration or response.” Replaced “ambient” with “natural”.
- 9.3 Removed “Laboratory Reagent Blank (LRB) – The laboratory must analyze at least one LRB with each batch of samples. The LRB consists of Nanopure water treated the same as the samples. LRB data are used to assess contamination from the laboratory environment.” and “Quality Control Sample (QCS)/ Standard Reference Material (SRM) – when using this procedure, a quality control sample is required to be analyzed at the beginning of the run and end of the run, to verify data quality and acceptable instrument performance. If the determined concentrations are not within 3s of the certified values, performance of the determinative step of the method is unacceptable. The source of the problem must be identified and corrected before either proceeding with the initial determination of MDLs or continuing with the analyses. The results of these samples shall be used to determine batch acceptance.” and “The QCS will be obtained from a source external to the laboratory and different from the source of calibration standards.”
- 9.3 Added “The laboratory performs duplicate analysis of 10% of samples, or at least 1 per batch, whichever is higher.”
- 9.4.1 Changed 9 to 29
- 11.1.3 Added “staggering each pad”
- 11.1.4 removed “to room temperature”

- 11.1.8 Replaced “come to room temperature” with “cooled”
- 11.1.9 Section changed to “store in their boxes for future use”
- 11.1.13 Removed “and” to create separate sentence; added “foil with sample”
- 11.1.15 Changed 11.1.7 to 11.1.8
- 11.2.1 Added “staggering each pad”
- 11.2.3 Changed 11.1.7 to 11.1.8
- 11.2.4 Replaced “come to room temperature” with “cooled”
- 11.2.9 Changed 11.1.7 to 11.1.8

1. SCOPE and APPLICATION

- 1.1 Gravimetric analysis is used to determine total suspended solids (TSS) and total volatile solids (TVS), also known as volatile suspended solids (VSS) using a four place analytical balance.
- 1.2 A Method Detection Limit (MDL) of 2.4 mg TSS/L and 0.9 mg TVS/L were determined using the Student's *t* value (3.14) times the standard deviation of seven replicates. If more than seven replicates are used to determine the MDL, refer to the Student's *t* test table for the appropriate *n*-1 value.
- 1.3 The quantitation limit for TSS was set at 0.0005 mg/L TSS.
- 1.4 This procedure should be used by analysts experienced in the theory and application of TSS. 1 month experience with an experienced analyst, certified in the analysis using the four place balance, is required.
- 1.5 This method can be used for all programs that require analysis of total suspended and volatile solids.
- 1.6 This procedure references EPA Method 160.2 and Standard Methods 208 E.

2. SUMMARY

- 2.1 Measured aliquots of a water sample are filtered through a pre-weighed glass fiber filter pad. These pads are placed into a 105° C drying oven overnight to remove any remaining water. The pads are removed from the oven and placed into a desiccator to cool. Once samples have cooled, they are individually weighed on a four place balance. Their respective weights are recorded in a spreadsheet and the concentration is reported as mg/L total suspended solids. If samples are to be used to determine total volatile solids they are placed into a numbered porcelain crucible and dried in a muffle furnace at 550° C for 1.5 hours. The samples are placed into a desiccator to cool. Once they have cooled, they are weighed on the four place balance and their weights are recorded into the spreadsheet.

3. DEFINITIONS

- 3.1 Acceptance Criteria – Specified limits placed on characteristics of an item, process, or service defined in a requirement document. (ASQC)
- 3.2 Accuracy – The degree of agreement between an observed value and an accepted reference value. Accuracy includes a combination of random error (precision) and systematic error (bias) components which are due to sampling and analytical operations; a data quality indicator. (QAMS)
- 3.3 Aliquot – A discrete, measured, representative portion of a sample taken for analysis. (EPA QAD Glossary)
- 3.4 Batch – Environmental samples, which are prepared and /or analyzed together with the same process and personnel, using the same lot(s) of

reagents. An **analytical batch** is composed of prepared environmental samples (extracts, digestates, or concentrates) and/or those samples not requiring preparation, which are analyzed together as a group using the same calibration curve or factor. An analytical batch can include samples originating from various environmental matrices and can exceed 20 samples. (NELAC/EPA)

- 3.5** Blank- A sample that has not been exposed to the analyzed sample stream in order to monitor contamination during sampling, transport, storage or analysis. The blank is subjected to the usual analytical and measurement process to establish a zero baseline or background value and is sometimes used to adjust or correct routine analytical results. (ASQC)
- 3.6** Calibrate- To determine, by measurement or comparison with a standard, the correct value of each scale reading on a meter or other device, or the correct value for each setting of a control knob. The levels of the applied calibration standard should bracket the range of planned or expected sample measurements. (NELAC)
- 3.7** Calibration – The set of operations which establish, under specified conditions, the relationship between values indicated by a measuring device. The levels of the applied calibration standard should bracket the range of planned or expected sample measurements. (NELAC)
- 3.8** Calibration Method – A defined technical procedure for performing a calibration. (NELAC)
- 3.9** Corrective Action – Action taken to eliminate the causes of an existing nonconformity, defect or other undesirable situation in order to prevent recurrence. (ISO 8402)
- 3.10** Deficiency – An unauthorized deviation from acceptable procedures or practices. (ASQC)
- 3.11** Demonstration of Capability – A procedure to establish the ability of the analyst to generate acceptable accuracy. (NELAC)
- 3.12** Detection Limit – The lowest concentration or amount of the target analyte that can be determined to be different from zero by a single measurement at a stated degree of confidence.
- 3.13** Duplicate Analysis – The analyses of measurements of the variable of interest performed identically on two sub samples (aliquots) of the same sample. The results from duplicate analyses are used to evaluate analytical or measurement precision but not the precision of sampling, preservation or storage internal to the laboratory. (EPA-QAD)
- 3.14** Field Duplicates (FD1 and FD2) – Two separate samples collected at the same time and place under identical circumstances and treated exactly the same throughout field and laboratory procedures. Analyses of FD1 and FD2 provide a measure of the precision associated with sample collection, preservation and storage, as well as with laboratory procedures.
- 3.15** Field Reagent Blank (FRB) – A aliquot of reagent water or other blank matrix that is placed in a sample container in the laboratory and treated

as a sample in all respects, including shipment to the sampling site, exposure to the sampling site conditions, storage, preservation, and all analytical procedures. The purpose of the FRB is to determine if method analytes or other interferences are present in the field environment.

- 3.16** Furnace – Combusts samples at 550°C.
- 3.17** Holding time – The maximum time that samples may be held prior to analysis and still be considered valid (40 CFR Part 136). The time elapsed from the time of sampling to the time of extraction or analysis, as appropriate.
- 3.18** Laboratory Duplicates (LD1 and LD2) – Two aliquots of the same sample taken in the laboratory and analyzed separately with identical procedures. Analyses of LD1 and LD2 indicate precision associated with laboratory procedures, but not with sample collection, preservation, or storage procedures.
- 3.19** Laboratory Reagent Blank (LRB) – A blank matrix (i.e., reagent water) that is treated exactly as a sample including exposure to all glassware, equipment, solvents, and reagents that are used with other samples. The LRB is used to determine if method analytes or other interferences are present in the laboratory environment, the reagents, or the instrument.
- 3.20** Limit of Detection (LOD) – The lowest concentration level that can be determined by a single analysis and with a defined level of confidence to be statistically different from a blank. Laboratory interchanges LOD and MDL. (ACS)
- 3.21** Limit of Quantitation (LOQ) – The minimum levels, concentrations, or quantities of a target variable (target analyte) that can be reported with a specified degree of confidence. The LOQ is set at 3 to 10 times the LOD, depending on the degree of confidence desired. Also referred to as quantitation limit.
- 3.22** Material Safety Data Sheets (MSDS) – Written information provided by vendors concerning a chemical's toxicity, health hazards, physical properties, fire, and reactivity data including storage, spill, and handling precautions.
- 3.23** May – Denotes permitted action, but not required action. (NELAC)
- 3.24** Method Detection Limit (MDL) – The minimum concentration of an analyte that can be identified, measured, and reported with 99% confidence that the analyte concentration is greater than zero. (Standard Methods)
- 3.25** Must – Denotes a requirement that must be met. (Random House College Dictionary)
- 3.26** Precision – The degree to which a set of observations or measurements of the same property, obtained under similar conditions, conform to themselves; a data quality indicator. Precision is usually expressed as standard deviation, variance or range, in either absolute or relative terms. (NELAC)

- 3.27** Preservation – Refrigeration, freezing, and/or reagents added at the time of sample collection (or later) to maintain the chemical and or biological integrity of the sample.
- 3.28** Quality Control Sample (QCS) – A sample of analytes of known and certified concentrations. The QCS is obtained from a source external to the laboratory and different from the source of calibration standards. It is used to check laboratory performance with externally prepared test materials.
- 3.29** Sample Volume – Amount of volume filtered.
- 3.30** Sensitivity – The capability of a test method or instrument to discriminate between measurement responses representing different levels (concentrations) of a variable of interest.
- 3.31** Shall – Denotes a requirement that is mandatory whenever the criterion for conformance with the specification requires that there be no deviation. (ANSI)
- 3.32** Should – Denotes a guideline or recommendation whenever noncompliance with the specification is permissible. (ANSI)

4. INTERFERENCES

- 4.1** Excessive residue may form a water trapping crust. Sample size should be limited to yield < 200 mg of residue.
- 4.2** Samples from saline waters will not weigh to a constant weight. Therefore they must be rinsed with copious amounts of distilled water.

5. SAFETY

- 5.1** Safety precautions must be taken when handling reagents, samples and equipment in the laboratory. Protective clothing including lab coats, safety glasses and enclosed shoes may be worn. In certain situations it may also be necessary to use gloves and goggles. Contact Solomons Rescue Squad (911) if emergency treatment is needed and also inform the Chesapeake Biological Laboratory (CBL) Associate Director of Administration and Facilities Maintenance of the incident. Contact the CBL Associate Director of Administration and Facilities Maintenance if additional treatment is required.
- 5.2** The muffle furnace becomes extremely hot. Use care when removing crucibles from the furnace. Be sure they have cooled to the touch. Use gloves or tongs if necessary.

6. EQUIPMENT AND SUPPLIES

- 6.1** A four place analytical balance.
- 6.2** Desiccator with drying agents such as anhydrous calcium sulfate or silica.
- 6.3** Drying oven capable of heating to 105° C
- 6.4** Muffle furnace capable of heating to 550° C.

6.5 Freezer, capable of maintaining $-20^{\circ} \pm 5^{\circ}$ C.

7. REAGENTS AND STANDARDS

7.1 Purity of Water – Unless otherwise indicated, references to water shall be understood to mean reagent water conforming to ASTM Specification D 1193, Type I. Freshly prepared water should be used for making the standards intended for calibration. The detection limits of this method will be limited by the purity of the water and reagents used to make the standards.

7.2 Blanks – ASTM D1193, Type I water is used for the LRB.

7.3 Quality Control Sample (QCS) – For this procedure, the QCS can be any certified dissolved sample which is obtained from an external source. If a certified sample is not available, then use the standard material.

8. SAMPLE COLLECTION, PRESERVATION, AND STORAGE

8.1 Water collected for TSS and/or TVS should be filtered through a Whatman GF/F glass fiber filter (nominal pore size $0.7 \mu\text{m}$), or equivalent.

8.2 Samples should be placed into an aluminum foil pouch and should be frozen at -20° C.

8.3 Frozen TSS/TVS samples may be stored longer than 28 days.

9. QUALITY CONTROL

9.1 The laboratory is required to operate a formal quality control (QC) program. The minimum requirements of this program consist of an initial demonstration of laboratory capability and the continued analysis of laboratory instrument blanks and calibration standard material, analyzed as samples, as a continuing check on performance. The laboratory is required to maintain performance records that define the quality of data generated.

9.2 Initial Demonstration of Capability

9.2.1 The initial demonstration of capability (iDOC) – is used to characterize instrument performance (MDLs) and laboratory performance (analysis of QC samples) prior to the analyses conducted by this procedure.

9.2.2 Method Detection Limits (MDLs) – MDLs should be established for TSS and TVS using a low level natural water sample. To determine the MDL values, analyzed seven replicate aliquots of water. Perform all calculations defined in the procedure (Section 11.3) and report the concentration values in the appropriate units. Calculate the MDL as follows:

$$\text{MDL} = St_{(n-1, 1-\alpha=0.99)}$$

Where, S = Standard deviation of the replicate analyses.

n=number of replicates

$t_{(n-1, 1-\alpha=0.99)}$ = Student's t value for the 99% confidence level with $n-1$ degrees of freedom ($t=3.14$ for 7 replicates.)

MDLs should be determined annually or whenever there is a significant change in instrumental configuration or response.

9.3 Assessing Laboratory Performance

9.3.1 The laboratory performs duplicate analysis of 10% of samples, or at least 1 per batch, whichever is higher.

9.4 Data Assessment and Acceptance Criteria for Quality Control Measures

9.4.1 If a Total Volatile Solid (TVS) result is more than the Total suspended Solid (TSS) result, an error code 29 is assigned to the sample.

9.4.2 If duplicates have been provided for a sample, the results of the two numbers must be compared to each other. If the difference between the two numbers is equal to or more than 50% of the lower number then an error code 14 is assigned.

9.5 Corrective Actions for Out of Control Data

9.5.1 Out of control data is not reported. Generally portions of the pad are missing and therefore the measurement is considered useless. An error code is assigned.

10. CALIBRATION AND STANDARDIZATION

10.1 Calibration – Daily checks of calibration of balance using a certified weight must be performed before sample analysis may begin. The balance is professionally calibrated annually.

11. PROCEDURE

11.1 Total Suspended Solids

11.1.1 On a clean piece of paper lay out filter pads for numbering

11.1.2 Use a Sharpie permanent ultra fine or very fine point black marker, sequentially number outside edge of each pad with a unique label.

11.1.3 After pads have been labeled, place in a Pyrex dish, staggering each pad, and dry overnight in a 105° C oven.

11.1.4 When ready to weigh, remove pads from oven and place into a desiccator to cool.

11.1.5 Turn on analytical balance and computer.

11.1.6 Perform a balance calibration. Check calibration by weighing a certified weight. Record weight on bench sheet.

- 11.1.7 Click on BalanceLink icon and be sure balance has been detected.
- 11.1.8 After pads have cooled, weigh pads individually on balance and enter data into respective spread sheets.
- 11.1.9 Store pads in their labeled boxes for future use.
- 11.1.10 When ready to sample, place pad **numbered side down** onto filtering apparatus.
- 11.1.11 Filter a known volume of sample through the filter pad.
- 11.1.12 Rinse pad very well with reagent water to rinse down filter tower and remove any salts from the pad.
- 11.1.13 Fold pad in half, sample side in and place pad into a labeled foil pouch. Place foil with sample in labeled storage bag and store in -20° C freezer. Place replicate pads side by side in pouch and not on top of each other.
- 11.1.14 When ready to analyze, place opened pouch with sample in 105° C drying oven overnight.
- 11.1.15 Repeat steps 11.1.4 – 11.1.8.
- 11.1.16 Reweigh certified weight and record on bench sheet.

11.2 Total Volatile Solids

- 11.2.1 Place pads straight from box into a nickel crucible and combust at 550° C in a muffle furnace for 1.5 hours.
- 11.2.2 Move pads to a 105° C oven for storage until ready to use.
- 11.2.3 Repeat steps 11.1.4 – 11.1.7.
- 11.2.4 After pads have cooled, weigh pads individually on balance and enter data into respective spread sheets and store into individually labeled Petri dishes for future use.
- 11.2.5 When ready to sample, place pad onto filtering apparatus.
- 11.2.6 Repeat steps 11.1.10 – 11.1.13
- 11.2.7 Repeat steps 11.1.4 – 11.1.8 to determine the TSS value.
- 11.2.8 Once TSS value has been determined place pad into a numbered porcelain crucible. Record crucible number and sample ID.
- 11.2.9 Combust samples at 550° C in a muffle furnace for 1.5 hours.
- 11.2.10 Repeat steps 11.1.4 – 11.1.8.
- 11.2.11 Reweigh certified weight and record on bench sheet.

11.3 Calculations

- 11.3.1 Calculate TSS value:

$$\text{mgTSS} / \text{L} = \frac{(\text{W}_{\text{post}(\text{g})} - \text{W}_{\text{pre}(\text{g})}) \times 1000}{\text{V} (\text{L})}$$

11.3.2 Calculate TVS:

$$mgTVS / L = \frac{(W_{post(g)} - W_{combust(g)}) \times 1000}{V(L)}$$

12. REFERENCES

12.1 APHA. 1975. Method 208D. Total Nonfilterable Residue Dried at 103-105 C (Total Suspended Matter) *in* Standard Methods for the Examination of Water and Wastewater, 14th Edition. American Public health Association. Washington, D.C. 460pp.

12.2 USEPA 1979 Method No. 160.2 (with slight modification) *in* Methods for chemical analysis of water and wastes. United States Environmental Protection Agency, Office of Research and Development. Cincinnati, Ohio. Report No. EPA-600/4-79-020 March 1979. 1193 pp.

University of Maryland Center for Environmental Science
Chesapeake Biological Laboratory
Nutrient Analytical Services
146 Williams St., Solomons, MD 20688
<http://nasl.cbl.umces.edu/>

**Standard Operating Procedure for
Spectrophotometric Determination of Chlorophyll α in waters and sediments of
Fresh/Estuarine/Coastal Areas.**
(References: SM10200H, EPA 446.0)

Revision 2017-1
Replaces Revision 2015
Effective April 27, 2017

Revised by: _____ Date: _____

Reviewed by: _____ Date: _____

Laboratory Supervisor: _____ Date: _____

Changes affecting Revision 2015:

Section 1.3: Added: The reporting limit is equal to the MDL.

Section 2.1: Added descriptor Lorenzen's modified monochromatic equation and Jeffrey and Humphrey trichromatic equation.

Section 3.6: Removed definition of preparation batch.

Section 3.27: Added: also known as MDL.

Section 3.28: Added: also known as Quantitation Limit.

Section 3.38: Added: also known as the CRM.

Section 3.40: Removed: and including the transfer of run cycle data to the disc.

Section 3.45: Added: Also known as CRM.

Section 4.1: Added: When ready to analyze, the extract must be at room temperature and the analysis performed under reduced lighting.

Section 5.1: Replaced Business Manager with Associate Director of Administration and Facilities

Section 5: Updated Chemical Safety Data.

Section 7.3: replaced de-ionized with reagent

Section 7.4: replaced de-ionized with reagent

Section 7.6.2: Added: Spectrophotometric chlorophyll α standard, PN10-950, ordered from Turner Designs. Standard Package includes one 20mL ampoule with a known concentration of Chlorophyll α Primary Standard in 90% acetone solution

Shelf Life: 1-year from manufacturing date, un-opened and stored in freezer at -20° C.

Section 8.4: changed – may be stored for an additional 30 days- to –and should be analyzed within the original holding time. Added: should be stored at -20° C or lower

Section 10.1: Added the word – checks-

Section 10.3: Added - A certified reference material such as Didymium or Holmium Oxide cell or filter used to check wavelength accuracy should be used quarterly.

Section 11.1.7: changed rpm to 500-675g and included calculation to determine rpms. r = radius of the rotor in millimeters Added: (usually found on the manufacturer's website) Also added: Using a syringe, withdraw the sample and filter into the cuvette.

Section 11.3.1: Added – Press GO TO WL and change the wavelength to 750 nm. Open the Method.

Section 12: Calculations: removed mg/m^3 .

p.15: added example of Spec chla bench sheet

1. SCOPE and APPLICATION

- 1.1 This is an acetone extraction method to determine chlorophyll α in fresh, estuarine waters, and coastal waters.
- 1.2 A Method Detection Limit (MDL) of 0.62 $\mu\text{g/L}$ active chl α and 0.74 $\mu\text{g/L}$ phaeophytin was determined using the Student's t value (3.14, $n=7$) times the standard deviation of a minimum of 7 replicates. If more than seven replicates are used to determine the MDL, refer to the Student's t test table for the appropriate $n-1$ value.
- 1.3 The quantitation limit for chl α is dependent upon the volume of sample filtered. The reporting limit is equal to the MDL.
- 1.4 This procedure should be used by analysts experienced in the theory and application of chlorophyll analysis. A three month training period with an analyst experienced in the analysis using the spectrophotometer is required.
- 1.5 This method can be used for all programs that require spectrophotometric analysis of chlorophyll α .
- 1.6 This procedure is based on Standard Methods 10200H, 19th Edition and EPA Method 446.0.

2. SUMMARY

- 2.1 Chlorophyll α is extracted from phytoplankton cells using a 90% solution of acetone. The samples are refrigerated in the dark from 2 to 24 hours (over night is preferable). After the appropriate time, the samples are centrifuged to separate the sample material from the extract. Because the waters of the Maryland portion of the Chesapeake Bay are relatively turbid, the sample extract is filtered through a 0.45 μm PTFE or nylon syringe filter and transferred into a clean tube, and centrifuged again for 20 minutes. The extract is analyzed on a spectrophotometer. To determine phaeophytin and active chl α , the extract is then acidified using 1N HCl, and reread. The concentrations are then calculated using Lorenzen's modified monochromatic equation. Uncorrected chlorophyll may be determined using the Jeffrey and Humphrey trichromatic equation.

3. DEFINITIONS

- 3.1 Absorbance – A measure of the amount of light at a specific wavelength absorbed by a liquid.
- 3.2 Acceptance Criteria – Specified limits placed on characteristics of an item, process, or service defined in a requirement document. (ASQC)
- 3.3 Accuracy – The degree of agreement between an observed value and an accepted reference value. Accuracy includes a combination of random error (precision) and systematic error (bias) components which are due to sampling and analytical operations; a data quality indicator. (QAMS)

- 3.4 Aliquot – A discrete, measured, representative portion of a sample taken for analysis. (EPA QAD Glossary)
- 3.5 Analytical Range – The analytical range is dependent on the volume of water filtered and the volume of acetone used in the extraction.
- 3.6 Batch – Environmental samples, which are prepared and /or analyzed together with the same process and personnel, using the same lot(s) of reagents. An **analytical batch** is composed of prepared environmental samples (extracts, digestates, or concentrates) and/or those samples not requiring preparation, which are analyzed together as a group using the same calibration curve or factor. An analytical batch can include samples originating from various environmental matrices and can exceed 20 samples. (NELAC/EPA)
- 3.7 Blank- A sample that has not been exposed to the analyzed sample stream in order to monitor contamination during sampling, transport, storage or analysis. The blank is subjected to the usual analytical and measurement process to establish a zero baseline or background value and is sometimes used to adjust or correct routine analytical results. (ASQC)
- 3.8 Calibrate- To determine, by measurement or comparison with a standard, the correct value of each scale reading on a meter or other device, or the correct value for each setting of a control knob. The levels of the applied calibration standard should bracket the range of planned or expected sample measurements. (NELAC)
- 3.9 Calibration – The set of operations which establish, under specified conditions, the relationship between values indicated by a measuring device. The levels of the applied calibration standard should bracket the range of planned or expected sample measurements. (NELAC)
- 3.10 Calibration Curve – The graphical relationship between known values, such as concentrations, or a series of calibration standards and their analytical response. (NELAC)
- 3.11 Calibration Method – A defined technical procedure for performing a calibration. (NELAC)
- 3.12 Calibration Standard – A substance or reference material used to calibrate an instrument. (QAMS)
 - 3.12.1 Initial Calibration Standard (STD) – A series of standard solutions used to initially establish instrument calibration responses and develop calibration curves for individual target analytes.
 - 3.12.2 Initial Calibration Verification (ICV) – An individual standard, analyzed initially, prior to any sample analysis, which verifies acceptability of the calibration curve or previously established calibration curve.
 - 3.12.3 Continuing Calibration Verification (CCV) – An individual standard which is analyzed after every 10-15 field sample analysis.
- 3.13 Certified Reference Material (CRM) – A reference material one or more of whose property values are certified by a technically valid procedure,

accompanied by or traceable to a certificate or other documentation which is issued by a certifying body. (ISO 17025)

- 3.14 Corrective Action – Action taken to eliminate the causes of an existing nonconformity, defect or other undesirable situation in order to prevent recurrence. (ISO 8402)
- 3.15 Deficiency – An unauthorized deviation from acceptable procedures or practices. (ASQC)
- 3.16 Demonstration of Capability – A procedure to establish the ability of the analyst to generate acceptable accuracy. (NELAC)
- 3.17 Detection Limit – The lowest concentration or amount of the target analyte that can be determined to be different from zero by a single measurement at a stated degree of confidence.
- 3.18 Duplicate Analysis – The analyses of measurements of the variable of interest performed identically on two sub samples (aliquots) of the same sample. The results from duplicate analyses are used to evaluate analytical or measurement precision but not the precision of sampling, preservation or storage internal to the laboratory. (EPA-QAD)
- 3.19 External Standard (ES) – A pure analyte (anacystis nidulans algae, or equivalent) that is measured in an experiment separate from the experiment used to measure the analyte(s) in the sample. The signal observed for a known quantity of the pure external standard is used to calibrate the instrument response for the corresponding analyte(s). The instrument response is used to calculate the concentrations of the analyte(s) in the unknown sample.
- 3.20 Field Duplicates (FD1 and FD2) – Two separate samples collected at the same time and place under identical circumstances and treated exactly the same throughout field and laboratory procedures. Analyses of FD1 and FD2 provide a measure of the precision associated with sample collection, preservation and storage, as well as with laboratory procedures.
- 3.21 Field Reagent Blank (FRB) – An aliquot of reagent water or other blank matrix that is placed in a sample container in the laboratory and treated as a sample in all respects, including shipment to the sampling site, exposure to the sampling site conditions, storage, preservation, and all analytical procedures. The purpose of the FRB is to determine if method analytes or other interferences are present in the field environment.
- 3.22 Holding time – The maximum time that samples may be held prior to analysis and still be considered valid. (40 CFR Part 136) The time elapsed from the time of sampling to the time of extraction or analysis, as appropriate.
- 3.23 Instrument Detection Limit (IDL) – The minimum quantity of analyte of the concentration equivalent which gives an analyte signal equal to three times the standard deviation of the background signal at the selected wavelength, mass, retention time absorbance line, etc.
- 3.24 Laboratory Duplicates (LD1 and LD2) – Two aliquots of the same sample taken in the laboratory and analyzed separately with identical procedures. Analyses

of LD1 and LD2 indicate precision associated with laboratory procedures, but not with sample collection, preservation, or storage procedures.

- 3.25 Laboratory Reagent Blank (LRB) – A matrix blank (i.e., 90% acetone) that is treated exactly as a sample including exposure to all glassware, equipment, solvents, and reagents that are used with other samples. The LRB is used to determine if method analytes or other interferences are present in the laboratory environment, the reagents, or the instrument.
- 3.26 Laboratory Control Sample (LCS) – A sample matrix, free from the analytes of interest, spiked with verified known amounts of analytes from a source independent of the calibration standard or a material containing known and verified amounts of analytes. The LCS is generally used to establish intra-laboratory or analyst-specific precision and bias or to assess the performance of all or a portion of the measurement system. (NELAC)
- 3.27 Limit of Detection (LOD) – The lowest concentration level that can be determined by a single analysis and with a defined level of confidence to be statistically different from a blank (ACS), also known as MDL.
- 3.28 Limit of Quantitation (LOQ) – The minimum levels, concentrations, or quantities of a target variable (target analyte) that can be reported with a specified degree of confidence. The LOQ is set at 3 to 10 times the LOD, depending on the degree of confidence desired. Also known as Quantitation Limit.
- 3.29 Linear Dynamic Range (LDR) – The absolute quantity over which the instrument response to an analyte is linear. This specification is also referred to as the Linear Calibration Range (LCR).
- 3.30 Material Safety Data Sheets (MSDS) – Written information provided by vendors concerning a chemical’s toxicity, health hazards, physical properties, fire, and reactivity data including storage, spill, and handling precautions.
- 3.31 May – Denotes permitted action, but not required action. (NELAC)
- 3.32 Method Detection Limit (MDL) – The minimum concentration of an analyte that can be identified, measured, and reported with 98% confidence that the analyte concentration is greater than zero.
- 3.33 Monochromatic equation – Also known as Lorenzen’s modified monochromatic equation, it requires the absorbance values of 664 and 665 nm before and after an acidification step of 90 seconds to calculate the amount of chlorophyll *a* and phaeophytin in the sample. The chlorophyll *a* is reported as corrected for phaeophytin. Chlorophyll *b* and *c* cannot be calculated using this equation.
- 3.34 Must – Denotes a requirement that must be met. (Random House College Dictionary)
- 3.35 Path Length – The path length is the width of the cuvette cell (length between optical non-frosted sides). For this method, 5 and 1 cm path length cuvettes are used.
- 3.36 Precision – The degree to which a set of observations or measurements of the same property, obtained under similar conditions, conform to themselves; a data

quality indicator. Precision is usually expressed as standard deviation, variance or range, in either absolute or relative terms. (NELAC)

- 3.37 Preservation – Refrigeration, freezing, and/or reagents added at the time of sample collection (or later) to maintain the chemical and or biological integrity of the sample.
- 3.38 Quality Control Sample (QCS) – A sample of analytes of known and certified concentrations. The QCS is obtained from a source external to the laboratory and different from the source of calibration standards. It is used to check laboratory performance with externally prepared test materials and is also known as the CRM.
- 3.39 Run – One sample analysis from start to finish, including printout.
- 3.40 Run Cycle – Typically a day of operation – the entire analytical sequence of runs from the first run to the last run.
- 3.41 Sample Volume – Volume of water filtered.
- 3.42 Sensitivity – The capability of a test method or instrument to discriminate between measurement responses representing different levels (concentrations) of a variable of interest.
- 3.43 Shall – Denotes a requirement that is mandatory whenever the criterion for conformance with the specification requires that there be no deviation. (ANSI)
- 3.44 Should – Denotes a guideline or recommendation whenever noncompliance with the specification is permissible. (ANSI)
- 3.45 Standard Reference Material (SRM) – Material which has been certified for specific analytes by a variety of analytical techniques and/or by numerous laboratories using similar analytical techniques. These may consist of pure chemicals, buffers, or compositional standards. The materials are used as an indication of the accuracy of a specific analytical technique. Also known as CRM.
- 3.46 Trichromatic equation – Also known as Jeffrey and Humphrey’s Trichromatic Equations, they require absorbance values at 664, 647, and 630 nm to calculate the amount of uncorrected chlorophyll *a* in a sample. Chlorophyll *b* and *c* pigments can also be determined. No acidification is required and phaeophytin cannot be calculated from this equation.

4. INTERFERENCES

- 4.1 Light and heat cause the chlorophyll molecule to break down. Therefore, the samples should be kept cold in the dark and care should be taken when grinding the samples so as not to overheat the sample. When ready to analyze, the extract must be at room temperature and the analysis performed under reduced lighting.
- 4.2 Any compound that absorbs light between 630 and 665 nm may interfere with chlorophyll measurement. The absorbance measurement at 750 nm is subtracted from the sample’s other measured absorbances (665, 664, 647, and 630 nm) to account for the turbidity of the clarified sample. If the absorbance at



750 nm is above 0.007 absorbance units (AU), the sample may be filtered one more time.

- 4.3 The spectral overlap of chlorophyll *a*, *b*, and *c* and phaeophytin can cause over or under-estimation of chlorophyll and/or phaeophytin. The amount of chlorophyll *b* and *c* in a sample is dependent on the taxonomic composition of the phytoplankton it contains. In the trichromatic equation, chlorophyll *a* may be overestimated in the presence of phaeophytin. In the monochromatic equation, chlorophyll *a* may be slightly overestimated in the presence of chlorophyll *b* and phaeophytin may be overestimated in the presence of carotenoids.

5. SAFETY

- 5.1 Safety precautions must be taken when handling reagents, samples and equipment in the laboratory. Protective clothing including lab coats, safety glasses and enclosed shoes should be worn. In certain situations, it will be necessary to also use gloves and/or a face shield. If solutions come in contact with eyes, flush with water continuously for 15 minutes. If solutions come in contact with skin, wash thoroughly with soap and water. Contact Solomons Rescue Squad (911) if emergency treatment is needed and also inform the CBL Associate Director of Administration and Facilities of the incident. Contact the CBL Associate Director of Administration and Facilities if additional treatment is required.
- 5.2 The toxicity or carcinogenicity of each reagent used in this procedure may not have been fully established. Each chemical should be regarded as a potential health hazard and exposure should be as low as reasonably achievable. Cautions are included for known hazardous materials and procedures.
- 5.3 Do not wear jewelry when troubleshooting electrical components. Even low voltage points are dangerous and can injure if allowed to short circuit.
- 5.4 The following hazard classifications are listed for the chemicals used in this procedure. Detailed information is provided on Material Safety Data Sheets (MSDS).

Table 1:

Chemical	Health Hazard	Fire Hazard	Instability Hazard	Specific Hazard	
Hydrochloric Acid	3	0	2	ACID, COR	
Acetone	1	3	0		

On a scale of 0 to 4 the substance is rated on four hazard categories: health, flammability, reactivity, and contact. (0 is non-hazardous and 4 is extremely hazardous)

HAZARD RATING

Health Hazard - Blue: 4 – deadly, 3 – extreme danger, 2 – hazardous, 1 – slightly hazardous, 0 – normal material

Fire Hazard - Red: Flash Points: 4 – below 73° F, 3 – below 100° F, 2 – below 200° F, 1 – above 200° F, 0 – will not burn

Instability Hazard - Yellow: 4 – may detonate, 3 – Shock and heat may detonate, 2 – violent chemical change, 1 – unstable is heated, 0 - stable

Specific Hazard - White: Acid = ACID, Alkali = ALK, Corrosive = COR, Oxidizer = OXY

6 EQUIPMENT AND SUPPLIES

6.1 A scanning spectrophotometer capable of measuring wavelengths within the visible range. This laboratory uses Shimadzu UV2401PC and UV2450PC spectrophotometers.

6.2 Freezer, capable of maintaining $-20^{\circ} \pm 5^{\circ}$ C.

6.3 Lab ware – All reusable lab ware (glass, Teflon, plastic, etc) should be sufficiently clean for the task objectives.

6.4 A centrifuge.

6.5 A Teflon pestle for grinding, either by hand or power, and/or a sonicator.

6.6 5-cm path length and 1-cm path length cuvettes of either special optical glass or quartz.

7 REAGENTS AND STANDARDS

7.1 Purity of Water – Unless otherwise indicated, references to water shall be understood to mean reagent water conforming to ASTM Specification D 1193, Type I. Freshly prepared water should be used for making the standards intended for calibration. The detection limits of this method will be limited by the purity of the water and reagents used to make the standards.

7.2 Purity of Reagents – Reagent grade chemicals shall be used in all tests. Unless otherwise indicated, it is intended that all reagents shall conform to specifications of the Committee on Analytical Reagents of the American Chemical Society, where such specifications are available. Other grades may be used, provided it is first ascertained that the reagent is of sufficiently high purity to permit its use without compromising the accuracy of the determination.

7.3 Acetone ($\text{H}_2\text{C}=\text{O}=\text{CH}_2$), 90% v/v

Acetone, reagent grade

900 ml

Reagent water 100 ml

Using a graduated cylinder, add 100 ml reagent water to 900 ml acetone.

7.4 Hydrochloric Acid, 1N –

Hydrochloric acid (HCl), concentrated, 8.6 ml

Reagent water, q.s. 100 ml

In a 100 ml volumetric flask, add 8.6 ml of concentrated hydrochloric acid to ~60 ml of reagent water. Dilute to 100 ml with reagent water.

7.5 Blanks – A reagent blank of 90% acetone is used.

7.6 Standards – Standards used are one of the following:

7.6.1 Chlorophyll α from *Anacystis nidulans* algae, PN C6144-1MG, ordered from Sigma/Aldrich. If chlorophyll from algae is not available, chlorophyll α from spinach may be substituted.

7.6.2 Turner Designs Spectrophotometric chlorophyll α standard, PN10-950. Standard Package includes one 20mL ampoule with a known concentration of Chlorophyll α Primary Standard in 90% acetone solution
Shelf Life: 1-year from manufacturing date, un-opened and stored in freezer at -20°C .

7.7 Quality Control Sample (QCS) – For this procedure, the QCS can be any certified sample which is obtained from an external source. If a certified sample is not available, then use the standard material.

8 SAMPLE COLLECTION, PRESERVATION, AND STORAGE

8.1 Water collected for chl α should be filtered through a Whatman GF/F glass fiber filter (nominal pore size 0.7 μm), or equivalent.

8.2 Water collected for chl α should be filtered as soon as possible. If immediate filtration is not possible, the water samples should be kept on ice in the dark and filtered within 24 hours.

8.3 The filtered sample is kept frozen at -20°C or lower. Filter pads should be folded in half and may be stored in folded aluminum foil pouches.

8.4 Frozen chl α filters should be extracted within 4 weeks. Once the sample is extracted, the clarified extract should be stored at -20°C or lower and should be analyzed within the original holding time.

9 QUALITY CONTROL

9.1 The laboratory is required to operate a formal quality control (QC) program. The minimum requirements of this program consist of an initial demonstration of laboratory capability and the continued analysis of laboratory instrument blanks and calibration standard material, analyzed as samples, as a continuing check on performance. The laboratory is required to maintain performance records that define the quality of data generated.

9.2 Initial Demonstration of Capability

- 9.2.1 The initial demonstration of capability (DOC) – is used to characterize instrument performance (MDLs) and laboratory performance (analysis of QC samples) prior to the analyses conducted by this procedure.
- 9.2.2 Method Detection Limits (MDLs) – MDLs should be established for chl_a using a low level ambient water sample. To determine the MDL values, analyze a minimum of seven replicate filtered aliquots of water. Perform all calculations defined in the procedure (Section 11) and report the concentration values in the appropriate units. Calculate the MDL as follows:

$$MDL = St_{(n-1, 1-\alpha=0.99)}$$

Where, $t_{(n-1, 1-\alpha=0.99)}$ = Student's *t* value for the 99% confidence level with *n*-1 degrees of freedom (*t* = 3.14 for 7 replicates)

n = number of replicates

S = Standard Deviation of the replicate

analyses.

- 9.2.3 MDLs should be determined yearly. If more than 7 replicates are analyzed, use the appropriate *n*-1 value obtained from the table for the Student's *t* test.

9.3 Assessing Laboratory Performance

- 9.3.1 Laboratory Reagent Blank (LRB) – The laboratory reagent blank is analyzed at the beginning of each sample run, after every tenth sample, and at the end of the run. The LRB consists of 90% acetone treated the same as the samples. LRB data are used to assess contamination from the laboratory environment.

9.4 Data Assessment and Acceptance Criteria for Quality Control Measures

- 9.4.1 The instrument optical performance is checked quarterly using a didymium reference standard which presents a wide range of crisply resolvable peaks which are easily used to correlate the wavelength indicator on the spectrophotometer to the known peak. Each peak reading should fall within the manufacturer's tolerance of the wavelength readout. If the criteria are not met, the instrument must be seen by a service technician.

9.5 Corrective Actions for Out of Control Data

- 9.5.1 The sample is first analyzed using the 5 cm path length cuvette. If the 665 nm reading is above 1.000 absorbance units, the sample should be reread using the 1 cm cuvette.

- 9.5.2 If the absorbance of the LRB shows an upward trend, AUTOZERO and re-BASELINE, then reread that LRB.

10 CALIBRATION AND STANDARDIZATION

- 10.1 Calibration – Quarterly optical performance checks are performed using a certified reference material such as Didymium or Holmium Oxide cell or filter used to check wavelength accuracy.

11 PROCEDURE

- 11.1 Sample Preparation – water column
- 11.1.1 Filter a known volume of water through a Whatman GF/F filter pad (nominal pore size 0.7 μm). Good color is needed on the pad. Do not rinse the pad.
 - 11.1.2 Fold pad in half, sample inside, wrap in aluminum foil, label and freeze for analysis within 4 weeks.
 - 11.1.3 Before analysis, briefly thaw pads, and then place in a 15 ml centrifuge tube. Add 10 ml of 90% acetone. Work under subdued lighting.
 - 11.1.4 Write all information in the lab bench sheet.
 - 11.1.5 Using a Teflon pestle, grind the filter against the side of the tube until the filter is well ground. If hand grinding, 10-15 seconds is all that is necessary. Power grinding requires vigilance, because excess heat will degrade the chlorophyll. Allow the sample to extract for 2 - 24 hours in the dark under refrigeration. Overnight is recommended.
 - 11.1.6 Remove tubes from refrigerator.
 - 11.1.7 Shake tubes, and then centrifuge at 500-675g for 30 minutes. Using a syringe, withdraw the sample and filter into the cuvette. If the samples are not analyzed that day the extract must be transferred to another tube. Pull the extract from the first tube and filter while transferring to a second numbered centrifuge tube. The extract is filtered through 0.45 μm PTFE or nylon syringe filters. The transferred samples may be stored in the freezer for up to 30 days after extraction. When ready to analyze the samples, centrifuge again for 20 minutes at 500-675g.
To calculate rpm use this formula:

$$\text{RCF} = 1.12r(\text{rpm}/1000)^2,$$

Where: RCF = relative centrifugal force

r = radius of the rotor in millimeters (usually found on the manufacturer's website)

rpm = speed of rotation

11.2 Pollution Prevention and Waste Management

11.2.1 This method generates hazardous waste.

11.2.2 Acetone waste is stored in 4 liter jugs in the cabinet under the hood and transferred to the hazardous waste area of the Storage Facility on campus.

11.2.3 Do not pour acetone down the sink.

11.2.4 Decant the waste acetone into the waste jugs, and then allow the remaining ground filter pad or sediment to dry in the hood.

11.2.5 The dried waste may then be put in the trash.

11.3 Using the Shimadzu UVProbe software:

11.3.1 Turn on the spectrophotometer (either the UV2401 or the UV2450) and the computer. Open the UVProbe software. Select photometric mode and connect to the instrument to turn on the lamps. Allow the instrument to run the lamp check and click OK. Allow the lamps to warm up for a minimum of 45 minutes before beginning sample analysis. Press GO TO WL and change the wavelength to 750 nm. Open the Method.

11.3.2 Using the 5 cm path length cuvettes, fill both the reference and sample cuvettes with 90% acetone. Wipe the windows of the cuvettes carefully with lens paper to dry. Click on AUTOZERO, then run a BASELINE. When the baseline is complete, label the first line of the sample table as blk1. Click on READ UNK (unknown) or press F9 to begin scanning. All wavelengths should be very close to zero. If not, AUTOZERO again, and rerun the BASELINE. Run blk2 if needed.

11.3.3 The reference cuvette is filled with 90% acetone and is left in place. Periodically check the liquid level, adding more 90% acetone as needed.

11.3.4 Begin analyzing samples. Enter the sample name in the sample table twice, once with a "b" designation for before acid, and again with an "a" designation for after acid.

11.3.5 Dispense sample into the sample cuvette. Wipe the windows of the cuvette carefully with lens paper and place in the cell holder.

11.3.6 Check the absorbance at 750 nm. If it is at 0.007 or below, press F9 to start the scan. If it is above 0.007, the sample may be filtered one more time through a 0.45 um ptfе syringe filter. If the 750 nm absorbance is still not below 0.007, proceed with the scan. It may

be necessary to recheck the zero if several samples in a row start above 0.007 at the 750 nm reading.

- 11.3.7 After the first scan is read, add enough 1N HCl to the sample to achieve a concentration of 0.003 N HCl within the sample. One drop of acid is used in the 1-cm path length cuvettes and 3 drops in the 5-cm cuvettes. Gently stir the sample for 30 seconds and wait another 30 seconds before starting the scan. A total of 90 seconds is needed to complete the reaction before reading. A 30 second wait is built into the method.
- 11.3.8 Rinse the sample cuvette with acetone after each sample. Then rinse with a small amount of sample before filling.
- 11.3.9 Repeat steps 11.3.4 through 11.3.6 for all samples, adding a blank after every 10 samples.
- 11.3.10 Run a blank at the end
- 11.3.11 Save the file. Right click on Properties.
- 11.3.12 Hide columns TYPE, EX, and CONC. Print file.
- 11.3.13 Save the file again as a text file to be imported into a spreadsheet for calculation.

12. Calculations:

Chlorophyll corrected for phaeophytin ($\mu\text{g/L}$):

$$\text{Chlorophyll } \alpha \text{ corrected (ug/L)} = \frac{26.7(664_B - 665_A) \times V_1}{V_2 \times L}$$

Phaeophytin ($\mu\text{g/L}$):

$$\text{Phaeophytin } \alpha \text{ (ug/L)} = \frac{26.7 [1.7(665_A) - 664_B] \times V_1}{V_2 \times L}$$

Uncorrected chlorophyll ($\mu\text{g/L}$):

$$\text{Chlorophyll } \alpha \text{ uncorrected (ug/L)} = \frac{[11.85(664_B) - 1.54(647_B) - 0.8(630_B)] \times V_1}{V_2 \times L}$$

Chlorophyll/Phaeophytin ratio:

Absorption peak ratio: $664_B/665_A$

Where: 664_B = Subtract 750 nm value (turbidity correction) from absorbance at 664 nm before acidification.

665_A = turbidity corrected absorbance at 665 nm after acidification.

647_B = turbidity corrected absorbance at 647 nm before acidification.

630_B = turbidity corrected absorbance at 630 nm before acidification.

V_1 = volume of extract (mL)

V_2 = volume of sample filtered (L)

L = path length (cm)

13 References:

- 13.1 APHA, Standard Methods for the Examination of Water and Wastewater, Method #10200H, 19th Edition.

- 13.2 EPA Method 446.0.

CHLOROPHYLL A SPEC BENCH DATA SHEET				BOX #	CRUISE:	
SPEC ID	UV2450	LOADED BY:			LOAD DATE:	
SPEC ID	UV2401	ANALYZED BY:			ANALYSIS DATE:	
SAMPLE ID	DATE	FIRST TUBE #	TRANSFER TUBE #	VOL. FILTERED	COMMENTS	
1						
2						
3						
4						
5						
6						
7						
8						
9						
10						
11						
12						
13						
14						
15						
16						
17						
18						
19						
20						
21						
22						
23						
24						
25						
26						
27						
28						
29						
30						
31						
32						
33						
34						
35						

APPENDIX VIII

MARYLAND DEPARTMENT OF NATURAL RESOURCES CHESAPEAKE BAY WATER QUALITY MONITORING PROGRAM

SPLIT SAMPLE PROGRAM

The following summarizes the split sample program and is excerpted from the [*Recommended Guidelines for Sampling and Analysis in the Chesapeake Bay Monitoring Program*](#). (EPA 1996). Information about the Split Sample and Blind Sample Programs program is available on-line at the EPA Chesapeake Bay Program web site: <http://www.chesapeakebay.net/about/programs/qa>.

Background and Objectives

The Chesapeake Bay Coordinated Split Sample Program (CSSP) was established in June 1989 by recommendation of AMQAW [the Chesapeake Bay Program Analytical Methods and Quality Assurance Workgroup], to the Monitoring Subcommittee. The major objective of this program is to establish a measure of comparability between sampling and analytical operations for water quality monitoring basin-wide. A secondary objective is to evaluate the in-matrix dilution of standard U.S. Environmental Protection Agency (EPA) reference materials. These standard reference materials are analyzed in appropriate matrix, fresh to saline, and concentration level to match the sample. All laboratories participating in basin-wide data collection programs are also required to participate in the CSSP.

Early in 2015, the Data Integrity Work Group (DIWG) was formed. The DIWG replaced the AMQAW. The goals and objectives of the DIWQ are similar to those of the AMQAW. The Data Integrity Work Group plans to complete the document “Methods and Quality Assurance for Chesapeake Bay Water Quality Monitoring Programs” and publish it on the Chesapeake Bay Program website.

For additional information on the program, please consult [*Chesapeake Bay Coordinated Split Sample Program Implementation Guidelines Rev. 4*](#), (EPA Dec. 2010), [*2015 Work Plan for the Chesapeake Bay Program Data Integrity Workgroup*](#), [*Data Integrity Workgroup \(formerly AMQAW\)*](#).

Summary of Criteria

- (1) The Participant will participate in the applicable component(s) of the CSSP.
- (2) The Standard Operating Procedures (SOPs) that are developed and used should be in accordance with the [*Chesapeake Bay Coordinated Split Sample Program Implementation Guidelines CBP/TRS 58/91, May 1991*](#) plus any revisions specified by the CBP Quality Assurance Officer.
- (3) For each of the Virginia and Maryland CSSP stations and on a quarterly basis, the Participant will receive and analyze four sub-samples. Since 1998, Maryland DNR has performed the sample split at one station and depth, (usually the surface sample at station CB4.4C). In recent years, the August split samples has been collected from the bottom as doing so often provides measurable P values for comparison.

Four sub samples will be collected for each participating laboratory. Samples to be analyzed at Virginia Labs will be delivered to Port Royal, VA, the afternoon of the day they are collected and processed the following morning. In order to treat all of the samples uniformly, the MD DNR field team will also wait until the next morning to process their split samples.

Laboratories currently participating in the CCSP program Mainstem sample analyses are: University of Maryland Chesapeake Biological Laboratory Nutrient Analytical Services Laboratory (CBL), University of Maryland Horn Point Laboratory (HPL), Old Dominion University College of Sciences Water Quality Laboratory (ODU), Virginia Division of Consolidated Laboratory Services (VADCLS) and Virginia Institute of Marine Science (VIMS).

Tributaries project CSSP samples are also analyzed by CBL, ODU and VADCLS as well as, the following list of laboratories: Delaware Department of Natural Resources and Environmental Control-DWR, District Department of the Environment, Fairfax County Department of Public Works, Maryland Dept. of Health and Mental Hygiene, National Water Quality Laboratory (twice a year), Pennsylvania Department of Environmental Protection - Bureau of Laboratories (twice a year) and Virginia Polytechnic Institute - Occoquan Laboratory. VIMS does not currently participate in tributaries sampling.

The Tributaries project CSSP sample is collected by the District Department of Environment, DC.

Treating each sub-sample as a discrete sample, participating laboratories are generally required to perform only those analyses which they routinely perform in support of basin-wide data collection program. One of the three sub-samples should be used to generate laboratory duplicates and a laboratory spike. These quality control (QC) samples should be analyzed concurrently with the associated CSSP sub-samples.

- (4) The routine submission of split sample data is the responsibility of each laboratory and its in-house data management organization.
- (5) To supplement the analyses of the three sub-samples and the respective QC sample, EPA standard reference materials provides a strong measure of comparability between all laboratories and within one laboratory's analytical system over time. Quarterly analysis of Standard Reference Materials (SRMs) is the most independent evaluation of laboratory performance available at this time. It is a critical element of any diagnostic efforts associated with the CSSP.

Examples of Split Sample information sheets and Custody Logs

An example of the field sheet used to record sample number, time of collection and salinity when split sample water is collected follows. Volumes are filled in the next morning when samples are processed for the Laboratories.

An example of a log sheet used to document the split sample Chain of Custody follows.

REFERENCES:

U.S. Environmental Protection Agency (EPA). 1996. [*Recommended Guidelines for Sampling and Analysis in the Chesapeake Bay Monitoring Program*](#). Chesapeake Bay Program, August 1996. CBP/TRS 148/96; EPA 903-R-96-006.

U.S. Environmental Protection Agency (EPA). 2010. [*Chesapeake Bay Coordinated Split Sample Program Implementation Guidelines Rev. 4*](#) Chesapeake Bay Program, December 2010.

[*2015 Work Plan for the Chesapeake Bay Program Data Integrity Workgroup*](#), Chesapeake Bay Program, January 2015.

Website: [*Data Integrity Workgroup \(formerly AMQAW\)*](#).

Split Sample Custody Log Example:

MAIN BAY SPLIT SAMPLE CUSTODY LOG

LOCATION: CB4.4

BOTTLE NUMBERS: E1,E2,E3,E4

COLLECTED FOR: Horn Point

COLLECTION DETAILS: DATE: _____ TIME: _____ DEPTH: _____ SALINITY: _____ PPT

COMMENTS: (unusual conditions, problems, floating algae, rain, etc.)

=====

SPLITTING DETAILS:	COMPOSITE SUB SPLIT BY:
COMPOSITE CONTAINER	sequential bottles
FILLED BY: submersible pump @	m into a 30 gallon Nalgene container

Splitting Sequence

Order # Agency	order # Agency	order # Agency	order # Agency
1---A1 VADCLS	6---A2 VADCLS	11---A3 VADCLS	16---A4 VADCLS
2---B1 ODU	7---B2 ODU	12---B3 ODU	17---B4 ODU
3---C1 CBL	8---C2 CBL	13---C3 CBL	18---C4 CBL
4---D1 VIMS	9---D2 VIMS	14---D3 VIMS	19---D4 VIMS
5---E1 HP	10- E2 HP	15---E3 HP	20- E4 HP

TRANSFER SEQUENCE:	DATE	TIME	BY WHOM?	TEMP. OF SAMPLE
Composite collected & split	_____	_____	DNR/_____	(circle one) ambient
Subsample picked up	_____	_____	_____	0°C 4°C ambient
Subsamples delivered to lab	_____	_____	_____	0°C 4°C ambient

=====

FIELD PROCESSING INFORMATION

BOTTLE #	FIELD PROCESSING DONE	DATE/TIME	BY WHOM?

=====

NOTE: PLEASE SEND A COPY OF THIS COMPLETED FORM TO: Main Bay Split, Lenora Dennis, Maryland Dept of Natural Resources, TEA/D-2, 580 Taylor Avenue, Annapolis MD, 21401, (410) 260-8647.

APPENDIX IX

MARYLAND DEPARTMENT OF NATURAL RESOURCES CHESAPEAKE BAY WATER QUALITY MONITORING PROGRAM

DATA STATUS FORM DOCUMENTATION AND PROCEDURES

The Data Status Form is used for all monthly water quality data for all monitoring projects. The form is designed to facilitate data management by tracking data management activities and identifying potential problems for remedy early in the process. Upon receiving the data sheets or files from the data source agencies (e.g., the Field Office and the laboratories), the data clerk initiates a Data Status Form, which then accompanies the data sheets/files. When all of data have been processed for that month, the Data Status Form is stored with the data sheets and other computer generated information at the DNR Tawes Office Building in Annapolis.

This sheet was developed in 1986 and updated in 1995. An updated web-based data status tracking form is being designed and will be implemented in the future. Note that many of the columns on the form are no longer actively used. The necessary information in the sheet is described in the following paragraphs. An example Data Status Form is attached for reference.

I. COMPLETE THE FOLLOWING WHEN THE FORM IS ISSUED:

1. DATE INITIATED (UPPER RIGHT HAND CORNER)

Indicate the date when the form is issued. In general, issue the form upon receiving the first group of data sheets and/or data files from data source agencies for a given month.

2. DATA SET NAME

Enter the data set name with the project abbreviation, data sampling month, year, and data type (e.g., TJAN98FD for tributary field data for January 1998). Refer to the detailed description of naming conventions at the end of this appendix.

3. DATA RECEIVED

Upon receiving the first group of data sheets and/or data files, enter the date and initial in this field.

II. COMPLETE THE FOLLOWING UPON FINISHING THE DATA MANAGEMENT PROCESS

1. DATA REVIEWED

Once all monthly data sheets and/or data files have been received and the data have been reviewed, enter completion date. Initial in this field.

2. CROSS REFERENCE

If the completed cross reference sheets are included with the incoming data sheets, enter the date and initial in this field. If, for some reason, cross reference sheets are not included, the Quality Assurance Officer would be notified, and s/he would contact the field office.

3. XEROXING

Before sending field data sheets to the data entry service agency, copy data sheets and send originals to the data entry service agency. Enter the completion date and initial in this field.

4. DATA ENTRY – SENT

Enter the date data sheets are sent to data entry service in this field. Initial.

5. DATA ENTRY – RETURNED

Enter the date that data sheets and data diskette are received from data entry service in this field. Initial.

6. INITIAL DATA CHECK

7. DATA VERIFICATION

8. TEMPORARY MERGE(S)

BIO CHECK (#9 - #13)

9. VERIFICATION(S)

10. EDIT(S) IDENTIFIED

11. DATA CORRECTION(S)

12. TEMPORARY MERGE(S)

13. BIOLOGIST SIGN OFF

14. FINAL DATA CORRECTION

15. MERGE COMPLETED

16. GENERATE MS ACCESS DATA SET

17. GENERATE EPA MS ACCESS DATA (This field generally is left blank–this step is included under “PRODUCE CBP DATA TRN FILE.”)

18. SUBMISSION DOCUMENT (This field generally is left blank–this step is included under “PRODUCE CBP DATA TRN FILE.”)

19. SUBMISSION LETTER (This field generally is left blank–this step is included under “PRODUCE CBP DATA TRN FILE.”)

20. FINAL SIGN-OFF

Upon verifying all of the above data management processes and ensuring that all corrections have been made, finalize the data set in the state data base system by running permanent merge process in the EZMERGE system, enter the completion date and initial in this field.

21. SUBMISSION TO CBP (PRODUCE CBP DATA TRN FILE)

Upon successfully creating data submission file, report, and document for the monthly data submission process, enter the completion date in this field and initial.

22. CBP ACCEPTS / SIGN OFF

After receiving the checklist and ACCEPTS/SIGN OFF form from CBP and upon completing all the necessary data verification actions (e.g., double checking errors), put the completion date in this field and initial.

NOTE: Any special comments can be entered in the COMMENTS column during the data management activities.

CONVENTIONS FOR NAMING THE DATA SET

An eight-character text string is used for this data set name. This section contains the naming conventions for data set names for all monitoring projects. Any new sampling monitoring and data collection projects must follow these conventions.

1. CHESAPEAKE BAY MAINSTEM MONITORING PROJECT

Data Set Name: MMMYYDDD

Description: The data set name contains the data sampling month, year, and data type only. The first three characters of the data set name (MMM) stand for the sampling month. The next two characters (YY) of the data set name are the last two digits of the sampling year. The last three characters of data set name (DDD) stand for sample collection type. The following types are available for this project:

DATA TYPE	DATA DESCRIPTION
FLD	Field Data
LAB	Laboratory Data
CHL	Chlorophyll Data

Example of Mainstem Data Set Name: For field data sheets for January 1998 data, the data set name is 'JAN98FLD'.

2. MARYLAND TRIBUTARY MONITORING PROJECT

Data Set Name: TMMMYDD

Description: The data set name begins with the project initial 'T', followed by the data sampling month (MMM), year (YY), and data type (DD). The last two characters of the data set name (DD) stand for data type. The following types are available for this project:

DATA TYPE	DATA DESCRIPTION
FD	Field Data
LB	Laboratory Data
CH	Chlorophyll Data

Example of a Tributary Data Set Name: For field data sheets for January 1998 data, the data set name is 'TJAN98FD'.

3. MARYLAND PATUXENT RIVER INTENSIVE SURVEY (PART OF MARYLAND TRIBUTARY MONITORING PROJECT)

Data Set Name: PTMMYYD

Description: The data set name begins with the project initials 'PT', followed by the data sampling month (MMM), year (YY), and data type (D). The last character of data set name (D) stands for data type. The following types are available for this project:

DATA TYPE	DATA DESCRIPTION
F	Field Data
L	Laboratory Data

[Note: Chlorophyll data for the Patuxent is included in the tributary data set.]

Example of a Patuxent Data Set Name: For field data sheets for January 1998 data, the data set name is 'PTJAN98F'.

Example of Monitoring Data Status Form

MARYLAND DEPARTMENT OF NATURAL RESOURCES DATA STATUS FORM		Control No. : <u>0002</u>			
* D.M. function ** D.M. verify only		Date Initiated: <u>2/22/06</u>			
* Data Set Name: <u>FEB06FLD</u>					
////////////////////		Project Dates		Initials	Comments
*	Data Received	<u>2/22/06</u>		<u>RVR</u>	
*	Data Reviewed	<u>2/22/06</u>		<u>RVR</u>	
**	Cross Reference				
*	Xeroxing Field sheets				
**	Data Entry Field/Lab/ Patuxent	Sent <u>3/16/06</u>		<u>RVR</u>	
		Returned <u>3/23/06</u>		<u>RVR</u>	
*	Initial Data Check				
*	Data Verification				
*	Temporary Merge(s)				
////////////////////		Check Records (Date/Initial)			
		1	2	3	4
B	Verification(s)				
I	* Edit(s) Identified				
O	* Data Correction(s)				
C	* Temporary Merge(s)				
H	Biologist Sign Off				
E	* Final Data Correction				
C	* Merge Completed				
K	* Generate FLC Data Set				
	* Generate EPA FLC Data				
	* Submission Document				
	* Submission Letter				
	Final Sign Off				
	Submission to CBP				
	CBP Data Check List(s)				
	CBP Accepts / Signoff				

APPENDIX X

MARYLAND DEPARTMENT OF NATURAL RESOURCES CHESAPEAKE BAY WATER QUALITY MONITORING PROGRAM

OUTLINE OF CODES FOR FIELD AND LABORATORY DATA SHEETS

This file contains the computer codes for water quality data that will be used for field and laboratory data sheets. The computer codes are listed with their corresponding descriptions.

OUTLINE OF CODES

FIELD DATA SHEETS

- Submitter Codes
- Data Category Codes
- Study Codes
- Sample Method Codes
- Tide State Codes
- Weather Codes
- Percentage Cloud Cover Codes
- Dissolved Oxygen Method Codes
- 'Value Corrected' Codes
- Sample Layer Codes
- Wind Direction Codes

LABORATORY DATA SHEETS

COMPUTER CODES FOR NUTRIENT PARAMETER ANALYSES SHEET

- Submitter Codes
- Data Category Codes
- Sample Method Codes
- Sample Layer Codes
- Study Codes
- Parameter Codes
- Analytical Problem Codes
- Detection Limit Codes
- Method Codes

COMPUTER CODES FOR CHLOROPHYLL PARAMETER ANALYSES SHEET

- Submitter Codes
- Data Category Codes
- Sample Layer Codes
- Study Codes
- Analytical Problem Codes

DETAILED DESCRIPTION OF CODES

BECAUSE THE NEW DATA BASE SYSTEM IS BEING DEVELOPED AND WILL REPLACE THE CURRENT DATA BASE SYSTEM IN THE NEAR FUTURE, MOST OF CURRENT COMPUTER CODES WILL BE DROPPED AFTER THE COMPLETION OF NEW DATA BASE SYSTEM. THE FOLLOWING LISTS ONLY THE MOST COMMONLY USED COMPUTER CODES.

FIELD DATA SHEETS

Submitter Codes:

Code	Data collection agency	Analytical lab
28	CBL/FIELD	CHEMICAL – CBL/LAB CHLOROPHYLL – DHMH through 12/31/2008 TURBIDITY - DHMH
60	DNR/TEA	CHEMICAL – CBL, DHMH CHLOROPHYLL – DHMH through 12/31/2008 CHLOROPHYLL – CBL beginning 1/1/2009
79	DNR/TEA	CHEMICAL – CBL CHLOROPHYLL – DHMH through 12/31/2008 CHLOROPHYLL – CBL beginning 1/1/2009

Data Category Codes: These codes are designed to indicate the type of data collected

Code	Description
AA	PRIMARY MONITORING SAMPLE - LAND
AB	PRIMARY MONITORING SAMPLE – BOAT
IN	WATER QUALITY INTENSIVE SURVEY DATA
NR	NON-POINT SOURCE/RUN-OFF SAMPLING DATA
MB	CHESAPEAKE BAY MONITORING WATER QUALITY SAMPLE -- MAIN BAY
MN	AUTOMATED MONITORING STUDY
MT	CHESAPEAKE BAY MONITORING WATER QUALITY SAMPLE -- MARYLAND TRIBUTARY
ST	SEDIMENT DATA SAMPLE
WQ	WATER QUALITY SAMPLE, UNSPECIFIED PROGRAM

Study Codes

Code	Description	Lab details
01	CHESAPEAKE BAY MONITORING PROGRAM – MAIN BAY	CHEMICAL – CBL CHLOROPHYLL – DHMH through 12/31/2008 CHLOROPHYLL – CBL beginning 1/1/2009
02	CHESAPEAKE BAY MONITORING PROGRAM – TRIBUTARY (includes PATUXENT)	CHEMICAL (PATUXENT) – DHMH through 6/1990 CHEMICAL (PATUXENT) – CBL beginning 7/1990 CHEMICAL (NON-PATUXENT) – DHMH through 4/1998 CHEMICAL (NON-PATUXENT) – CBL beginning 5/1998 CHLOROPHYLL – DHMH through 12/31/2008 CHLOROPHYLL – CBL beginning 1/1/2009
04	CORE/TREND MONITORING PROGRAM	CHEMICAL – DHMH (Whole Water) Through 6/2005 CHEMICAL – DHMH (Filtered Water) beginning 7/2005 CHLOROPHYLL – DHMH through 12/31/2008 CHLOROPHYLL – CBL beginning 1/1/2009
06	POTOMAC COORDINATED MONITORING PROGRAM - COG	CHEMICAL Tidal – DHMH though 4/1998 CHEMICAL Tidal – CBL beginning 5/1998 CHEMICAL Freshwater– DHMH (Whole Water) Through 6/2005 CHEMICAL Freshwater – DHMH (Filtered Water) beginning 7/2005 CHLOROPHYLL – DHMH through 12/31/2008 CHLOROPHYLL – CBL beginning 1/1/2009
08	COASTAL BAYS PROGRAM	CHEMICAL – CBL CHLOROPHYLL – DHMH through 12/31/2008 CHLOROPHYLL – CBL beginning 1/1/2009
09	ROUTINE FISH WATER QUALITY	CHEMICAL – CBL CHLOROPHYLL – DHMH through 12/31/2008 (last samples collected in 2002)
21	WATER QUALITY MAPPING (DATAFLOW)	CHEMICAL – CBL CHLOROPHYLL – DHMH through 12/31/2008 CHLOROPHYLL – CBL beginning 1/1/2009
22	CONTINUOUS MONITORING	CHEMICAL – CBL CHLOROPHYLL – DHMH through 12/31/2008 CHLOROPHYLL – CBL beginning 1/1/2009
97	ROUTINE PFIESTERIA WATER QUALITY	CHEMICAL – CBL CHLOROPHYLL – DHMH through 12/31/2008 (last samples collected in 2002)
99	RAPID RESPONSE PFIESTERIA WATER QUALITY	CHEMICAL – CBL CHLOROPHYLL – DHMH through 12/31/2008 (last samples collected in 2002)

Sample Method Codes

Code	Description
1	GRAB SAMPLE
7	FIELD MEASUREMENTS ONLY

Tide State Codes

Code	Description	Comment
E	EBB TIDE	STAGE OF WATER MOVEMENT FROM A HIGHER TO A LOWER LEVEL.
F	FLOOD TIDE	STAGE OF WATER MOVEMENT FROM A LOWER TO A HIGHER LEVEL.
L	LOWER SLACK TIDE	STAGE OF WATER WHERE THE LEVEL IS BELOW MEAN AND VELOCITY APPROACHES ZERO
H	HIGH SLACK TIDE	STAGE OF WATER WHERE THE LEVEL IS ABOVE MEAN AND VELOCITY APPROACHES ZERO
BLANK	NOT RECORDED	NOT APPLICABLE

Weather Codes

Code	Description
10	NONE
11	DRIZZLE
12	RAIN
13	HEAVY RAIN
14	SQUALLY
15	FROZEN PRECIPITATION
16	MIXED RAIN AND SNOW
BLANK	NOT RECORDED, OR NOT APPLICABLE

Percentage Cloud Cover Codes

PERCENTAGE CLOUD COVER IS REPORTED AS VALUES FROM 0 –100 %

Dissolved Oxygen Method Codes

Code	CBP_code	Description
H	F01	HYDROLAB
M	F02	YSI METER
W	F03	WINKLER METHOD
R	F04	YSI METER – RDOX; HYDROLAB - LDO
BLANK		NOT RECORDED, OR NOT APPLICABLE

'Value Corrected' Codes: These codes are designed to specify whether corrections have been made by the instrument calculation for the dissolved oxygen value.

Code	Description
N	NO CORRECTION
T	TEMPERATURE CORRECTION ONLY
C	TEMPERATURE AND CONDUCTIVITY CORRECTION

Sample Layer Codes

Code	Description
S	SURFACE SAMPLE
AP	ABOVE PYCNOCLINE
BP	BELOW PYCNOCLINE
B	BOTTOM SAMPLE
M	MID-DEPTH SAMPLE
BLANK	NOT RECORDED, OR NOT APPLICABLE

Wind Direction Codes

Code	Description
E	FROM THE EAST (90 DEGREES)
ENE	FROM THE EAST NORTHEAST (67.5 DEGREES)
ESE	FROM THE EAST SOUTHEAST (112.5 DEGREES)
N	FROM THE NORTH (0 DEGREES)
NE	FROM THE NORTHEAST (45 DEGREES)
NNE	FROM THE NORTH NORTHEAST (22.5 DEGREES)
NNW	FROM THE NORTH NORTHWEST (337.5 DEGREES)
NW	FROM THE NORTHWEST (315 DEGREES)
S	FROM THE SOUTH (180 DEGREES)
SE	FROM THE SOUTHEAST (135 DEGREES)
SSE	FROM THE SOUTH SOUTHEAST (157.5 DEGREES)
SSW	FROM THE SOUTH SOUTHWEST (202.5 DEGREES)
SW	FROM THE SOUTHWEST (225 DEGREES)
W	FROM THE WEST (270 DEGREES)
WNW	FROM THE WEST NORTHWEST (292.5 DEGREES)
WSW	FROM THE WEST SOUTHWEST (247.5 DEGREES)
NR	NOT RECORDED, OR NOT APPLICABLE

LABORATORY DATA SHEETS

COMPUTER CODES FOR NUTRIENT PARAMETER ANALYSES SHEET

Submitter Codes: The codes are the same as for field data sheets

Data Category Codes: The codes are the same as for field data sheets

Sample Method Codes: The codes are the same as for field data sheets

Sample Layer Codes: The codes are the same as for field data sheets

Study Codes: The codes are the same as for field data sheets

Parameter Codes:

Code	Description	Unit
BIOSI	PARTICULATE BIOGENIC SILICA	mg/L
BOD5W	FIVE DAY BIOLOGICAL OXYGEN DEMAND	mg/L
CHLA	ACTIVE CHLOROPHYLL A	µg/L
DOC	DISSOLVED ORGANIC CARBON AS C	mg/L
DON	DISSOLVED ORGANIC NITROGEN AS N	mg/L
DOP	DISSOLVED ORGANIC PHOSPHORUS AS P	mg/L
TDS	DISSOLVED SOLIDS if on filtered water sample	mg/L
FCOL_M	FECAL COLIFORM	MPN/100ml
FE_M	TOTAL IRON	mg/L
NH4F	AMMONIA AS N (FILTERED)	mg/L
NH4W	AMMONIA AS N (WHOLE)	mg/L
NO2F	NITRITE AS N (FILTERED)	mg/L
NO2W	NITRITE AS N (WHOLE)	mg/L
NO23F	NITRITE + NITRATE AS N (FILTERED)	mg/L
NO23W	NITRITE + NITRATE AS N (WHOLE)	mg/L
NO3F	NITRATE AS N (FILTERED)	mg/L
NO3W	NITRATE AS N (WHOLE)	mg/L
PC	PARTICULATE ORGANIC CARBON AS C	mg/L
PHEO	MONOCHROMATIC PHEOPHYTIN A	µg/L
PIP	PARTICULATE INORGANIC PHOSPHORUS	mg/L
PN	PARTICULATE ORGANIC NITROGEN AS N	mg/L
PO4F	DISSOLVED ORTHOPHOSPHATE AS P (FILTERED)	mg/L
PO4W	DISSOLVED ORTHOPHOSPHATE AS P (WHOLE)	mg/L
PP	PARTICULATE PHOSPHORUS AS P	mg/L
SIF	REACTIVE SILICA AS SI (FILTERED)	mg/L
SIW	REACTIVE SILICA AS SI (WHOLE)	mg/L
SO4F	SULFATE (FILTERED)	mg/L
SO4W	SULFATE (WHOLE)	mg/L
TALK	TOTAL ALKALINITY	mg/L
TCOLI_M	TOTAL COLIFORM	MPN/100ml
TDN	TOTAL DISSOLVED NITROGEN AS N (FILTERED)	mg/L
TDP	TOTAL DISSOLVED PHOSPHORUS AS P (FILTERED)	mg/L
TKNF	TOTAL KJELDAHL NITROGEN AS N (FILTERED)	mg/L
TKNW	TOTAL KJELDAHL NITROGEN AS N (WHOLE)	mg/L
TN	TOTAL NITROGEN	mg/L
TOC	TOTAL ORGANIC CARBON	mg/L
TP	TOTAL PHOSPHORUS	mg/L
TSS	TOTAL SUSPENDED SOLIDS	mg/L
TURB_NTU	TURBIDITY	NTU

Analytical Problem Codes (APC):

TEA Maryland Department of Natural Resources Tidal Ecosystem Assessment
CBP Environmental Protection Agency Chesapeake Bay Program Office
CBL University Of Maryland Center for Environmental Science, Chesapeake Biological Laboratory, Nutrient Analytical Services Laboratory

TEA Problem Code	CBP Problem Code	CBL Problem Code	Description
A	A	1	LABORATORY ACCIDENT
	AA		FIELD ACCIDENT
B	B		CHEMICAL MATRIX INTERFERENCE
BB	BB	19	TORN FILTER PAD
C	C	12	INSTRUMENT FAILURE, CBL: MECHANICAL/MATERIALS FAILURE
	CC		CANNOT CALCULATE GIVEN AVAILABLE DATA
D	D	2	INSUFFICIENT SAMPLE
DD	DD	15	SAMPLE SIZE NOT REPORTED (ASSUMED)
DM	P		LAB SAMPLE DEPTH MISMATCH WITH FIELD SAMPLE DEPTH
E	E		SAMPLE RECEIVED AFTER HOLDING TIME
	F		POST-CALIBRATION FAILURE LIKELY DUE TO EQUIPMENT DAMAGE AFTER SAMPLING; DATA APPEAR NORMAL
FF	FF	14	POOR REPLICATION BETWEEN PADS, MEAN REPORTED
	G		REPORTED VALUE IS BETWEEN MDL AND THE PRACTICAL QUANTITATION LEVEL (OR REPORTING LIMIT)
GG	GG		SAMPLE ANALYZED AFTER HOLDING TIME
H	H	3	ANALYSIS RUN BY ANOTHER LAB
	I		SUSPECT VALUE HAS BEEN VERIFIED CORRECT
	IQ		CANNOT DETERMINE IF PART EXCEEDS WHOLE VALUE AND WHETHER OR NOT DIFFERENCE IS WITHIN ANALYTICAL PRECISION
J	J		INCORRECT SAMPLE FRACTION FOR ANALYSIS
JJ	JJ		VOLUME FILTERED NOT RECORDED (ASSUMED)
K		4	SAMPLE FROZEN WHEN RECEIVED (RESULT QUESTIONABLE)
KK			PARAMETER NOT REQUIRED FOR STUDY

Analytical Problem Codes (APC) continued:

TEA Problem Code	CBP Problem Code	CBL Problem Code	Description
	L		LICOR CALIBRATION OFF BY >=10% PER YEAR. USE WITH CALC KD WHERE PROB OF LU, LS, LB EXIST IN RAW
	LB		LICOR CALIBRATION OFF BY >= 10% PER YEAR FOR BOTH AIR AND UPWARD FACING SENSORS
LL		16	SAMPLE MISLABELED
	LS		LICOR CALIBRATION OFF BY >= 10% PER YEAR FOR AIR SENSOR
	LU		LICOR CALIBRATION OFF BY >= 10% PER YEAR FOR UPWARD FACING SENSOR
M		5	SAMPLE RECEIVED WARM, (CBP: SAMPLE NOT PRESERVED PROPERLY)
MM	MM	17	OVER 20% OF SAMPLE ADHERED TO POUCH AND OUTSIDE OF PAD
	N		NONE
NN	NN	21	PARTICULATES FOUND IN FILTERED SAMPLE
	NQ		PART EXCEEDS WHOLE VALUE AND DIFFERENCE IS NOT WITHIN ANALYTICAL PRECISION
	NV		NEGATIVE CALCULATEDVALUE IS VALID GIVEN PRECISION OF MEASURED WATER QUALITY PARAMETERS; ACTUAL CALCULATED CONCENTRATION LIKELY IS LOW; POSSIBLY LESS THAN PQLS OF MEASURED WATER QUALITY PARAMETERS
P		7	LOST RESULTS
	P		PROVISIONAL DATA
PP	DD	22	ASSUMED SAMPLE VOLUME
	Q		ANALYTE PRESENT; REPORTED VALUE IS ESTIMATED; CONC IS BELOW THE RANGE FOR QUANTITATION
QQ	QQ	23	PART EXCEEDS WHOLE VALUE, YET DIFFERENCE IS WITHIN ANALYTICAL PRECISION
R	R	8	SAMPLE CONTAMINATED

TEA Problem Code	CBP Problem Code	CBL Problem Code	Description
RR	RR	18	NO SAMPLE RECEIVED BY LAB FROM FIELD OFFICE
S			SAMPLE CONTAINER BROKEN DURING ANALYSIS (CBP: LABORATORY ACCIDENT)
SS	SS		SAMPLE REJECTED DUE TO HIGH SUSPENDED SEDIMENT CONCENTRATION
T			NO PHEOPHYTIN IN SAMPLE
TP			TORN FILTER PAD
U	U		MATRIX PROBLEM RESULTING OF THE INTERRELATIONSHIP BETWEEN VARIABLES SUCH AS PH AND AMMONIA
	UN		For DCDOH data, these values are issues or are nulls with no assigned problem codes. 8/27/2008
UU			ANALYSIS DISCONTINUED
V	V	9	SAMPLE RESULTS REJECTED DUE TO QUALITY CONTROL CRITERIA
VV			STATION NOT SAMPLED DUE TO BAD FIELD CONDITIONS
WW	WW		HIGH OPTICAL DENSITY (750 NM); ACTUAL VALUE REPORTED
X	X	10	SAMPLE NOT PRESERVED PROPERLY
Y		11	ANALYZED IN DUPLICATE, RESULTS BELOW DETECTION LIMIT
Z			ANALYZED BY METHOD OF STANDARD ADDITIONS

Detection Limit Codes:

Code	Description
BLANK	NORMAL
G	GREATER THAN THE UPPER METHOD DETECTION LIMIT (MDL)
L	LESS THAN THE LOWER METHOD DETECTION LIMIT (MDL) AND STORED LOWER DETECTION LIMIT
U	VALUE LESS THAN LOWER METHOD DETECTION LIMIT (MDL) AND STORED IN REAL VALUE

Method Codes:

Code	Method title	Unit	Method	Cbp mthd_id
BOD5W	5-DAY BIOCHEMICAL OXYGEN DEMAND	mg/L	L01	23
CHLA	MONOCHROMATIC; SPECTROPHOTOMETRIC	µg/L	L01	108
DOC	COMBUSTION INFRARED METHOD	mg/L	L01	42
FE_M	TOTAL IRON; PHENANTHROLINE METHOD	mg/L	L01	87
NH4F	COLORIMETRIC; AUTOMATED PHENATE (INDOPHENOL)	mg/L	L01	76
NO23F	ENZYME CATALYZED NITRATE REDUCTION	mg/L	L03	471
NO2F	AUTOMATED; COLORIMETRIC; DIAZOTIZATION	mg/L	L01	44
NO3F	CALCULATED NO3F (SUBMITTED TO CBPO)	mg/L	C01	110
PC	PARTICULATE CARBON (inorg+organic)	mg/L	L01	51
PHEO	MONOCHROMATIC; SPECTROPHOTOMETRIC	µg/L	L01	71
PN	PARTICULATE NITROGEN	mg/L	L01	52
PO4F	ORTHOPHOSPHATE; AUTOMATED; ASCORBIC ACID	mg/L	L01	48
PP	PARTICULATE PHOSPHORUS; SEMI-AUTOMATED; DIRECT	mg/L	L01	11
SIF	COLORIMETRIC; AUTOMATED; MOLYBDENUM BLUE	mg/L	L01	53
SO4F	SULFATE; TURBIDIMETRIC METHOD	mg/L	L01	106
TALK	ALKALINITY; TITRIMETRIC; pH 4.5	mg/L	L01	16
TDN	ALKALINE PERSULFATE WET OXIDATION + ENZYME CATALYZED NITRATE REDUCTION	mg/L	L02	55
TDP	ALKALINE PERSULFATE WET OXIDATION + EPA365.1OR EPA 365	mg/L	L01	56
TDS	TOT. DISSOLVED SOLIDS; GRAVIMETRIC; DRIED AT 180 C	mg/L	L01	107
TKNF	SEMI-AUTOMATED BLOCK DIGESTOR; COLORIMETRIC; NITRO	mg/L	L02	60
TKNW	SEMI-AUTOMATED BLOCK DIGESTOR; COLORIMETRIC; NITRO	mg/L	L02	2
TSS	GRAVIMETRIC; DRIED AT 103-105 C	mg/L	L01	10
TURB_NTU	NEPHELOMETRIC	NTU	L01	24

COMPUTER CODES FOR CHLOROPHYLL PARAMETER ANALYSIS SHEET

Submitter Codes: The codes are the same as field data sheets

Data Category Codes: The codes are the same as field data sheets

Sample Layer Codes: The codes are the same as field data sheets

Study Codes: The codes are the same as field data sheets

Analytical Problem Codes: The codes are the same as laboratory data sheets

APPENDIX XI

MARYLAND DEPARTMENT OF NATURAL RESOURCES CHESAPEAKE BAY WATER QUALITY MONITORING PROGRAM

DATA ENTRY REQUEST FORM DOCUMENTATION AND PROCEDURES

When submitting a job for data entry service, a data entry request form must be completed with the information specified below. A sample data entry request form is attached to the end of this appendix for reference.

RESOURCE ASSESSMENT ADMINISTRATION DATA ENTRY REQUEST FORM

1. AGENCY CONTROL NO: _____

The agency control number is used by the Data Processing Department (D.P.D.) to track keypunch jobs. This number is assigned by the Maryland Department of Natural Resources (MDDNR) Data Processing Programmer Trainee when preparing the request form.

2. D.P.D. CONTROL NO: _____

The D.P.D. control number field is optional and can be used by the Department of Data Processing for tracking.

3. APPLICATION REQUESTED ID (JOB ID) _____

The application Requested ID is an eight-character alphanumeric value followed by a water quality monitoring project data type description enclosed in parentheses.

Three different request ID's are used for Maryland mainstem and tributary water quality monitoring field data sets: A34202CB (Main Bay field), A34200CB (Patuxent field) and A34205CB (Tributaries field).

4. Requested By: _____

The name of the MDDNR Data Processing Programmer Trainee is used to identify the person submitting the data entry request form to the Data Processing Department.

5. Date Sent: _____

Date sent is optional and may be used to document when the date the request form was sent to the Data Processing Department. The MDDNR Data Processing Programmer Trainee maintains a log of this information separately.

6. Date Originals Returned: _____

Date originals returned is optional and may be used to document the date the field sheet originals were returned to MDDNR. The MDDNR Data Processing Programmer Trainee maintains a log of this information separately.

7. Agency: _____

Agency is the agency submitting the data entry request to the Department of Data Processing. The abbreviation "DNR" for Department of Natural Resources is used in the agency field.

8. Telephone: _____

The telephone number is the voice contact number of the Data Processing Programmer Trainee who submitted the data entry request.

9. Email received: _____

The email received field is optional and may be used to indicate whether an electronic mail message was received by the Data Processing Programmer Trainee. The MDDNR Data Processing Programmer Trainee maintains this information in the form of email messages.

SPECIAL INSTRUCTIONS TO D.P.D.

Control Information

10. Deliver Documents To:

The deliver documents to information is: DNR, Tawes State Office Bldg, D-2, 580 Taylor Ave, Annapolis, MD 21401.

The DVD containing electronic files produced by the Data Processing Department, and the original field data sheets that were sent to the Data Processing Department with the data entry request should be delivered to DNR at the address specified above.

11. Dataset Name: _____

Enter the name of the .ORG file. For example, for Patuxent November 2015 field data, use the description 'MAY07LAB.ORG'.

12. REMARKS: _____

Comments may be enter in the remarks field.

Example of Data Entry Request form

RESOURCES ASSESMENT ADMINISTRATION
DATA ENTRY REQUEST FORM

AGENCY CONTROL NO: 0043 D.P.D. CONTROL NO: _____

APPLICATION REQUESTED ID (JOB ID)
A34200CB (Patuxent Field)

Requested By: Lenora Dennis Agency: DNR
 Date Sent: _____ Telephone: 410-260-8647
 Date Originals Returned: _____ Email Received: _____

SPECIAL INSTRUCTIONS TO D.P.D.

Control Information	Data Set Name
Deliver Documents To:	<u>PTNOV15F.ORG</u>
DNR	
Tawes State Office Bldg., D-2	
580 Taylor Ave.	
Annapolis, Md. 21401	



REMARKS

Note: the Date Received stamp in the example was applied when the original field sheets were received by the Department of Data Processing.

Appendix XII. Sample Verification Reports and Plots and Edit Form

Maryland Department of Natural Resources

Field Sheet

Station Name **Project Code** **Sequence Number**

Sample Date **Arrival Time** **Departure Time** **Sample Number** **Measured Depth** **Air Temperature** **Tide Code** **Weather Yesterday** **Weather Today** **Cloud Cover (%)** **Wave Height**

Wind Direction **Wind Min. Velocity** **Wind Max. Velocity** **Equipment Set Unit No.** **Probe Number** **Photometer Unit Number** **Pycnocline Lower** **Pycnocline Upper** **Secchi** **GL**

Description :

Parameter List:

Rep	Sample depth	Water Temp	PH	DO	SPCOND	Salinity	Calc. Salinity	Rep Code	Sample depth	Layor Code	INSDEC	INSUW	EPAR_S	EPARU_Z
1	0.5	5.7	8.2	11.9	21700	13	12.86	1	0.5	S				
1	1	5.7	8.2	11.8	21700	13	12.86	1	1	M				
1	2	5.7	8.2	11.9	21700	13	12.86	1	2	M				
1	3	5.7	8.2	11.8	21700	13	12.86	1	3	M				
1	5	5.6	8.3	12	21700	13	12.86	1	5	M				
1	7	5.6	8.2	12	21800	13	12.93	1	7	M				
1	9	5.6	8.2	11.7	21800	13	12.93	1	9	AP				
1	10	5.6	8.2	11.5	21800	13.1	12.93	1	10	M				
1	11	5.8	8.1	10.7	24000	14.1	14.4	1	11	M				
1	12	5.9	8	9.6	29900	18	18.41	1	12	M				
1	13	5.9	7.9	9.6	30000	18.6	18.48	1	13	M				
1	14	5.9	8	9.6	30100	18.6	18.55	1	14	M				
1	15	5.9	7.9	9.5	30200	18.7	18.62	1	15	M				
1	16	5.9	7.9	9.5	30300	18.7	18.69	1	16	M				
1	17	5.9	7.9	9.5	30500	18.9	18.83	1	17	M				
1	18	6	7.9	9.5	31300	19.4	19.38	1	18	M				
1	19	6	8	9.5	31400	19.5	19.45	1	19	BP				
1	21	6.1	8	9.5	31000	19.7	19.17	1	21	M				

Tuesday, March 28, 2006 Sample Agency Sample Officer Page 1 of 20

Maryland Department of Natural Resources

Project Code Chlorophyll Sheet Chl Sequence No 3-460
 Sample Date: 2/7/2006

Parameters:

Station Name	SEQ	Rep #	Layer Code	Sample Depth	EXVOL	APC	LIPAT	SAMVOL	OD630	OD645	OD647	OD663B	OD664B	OD665A	OD750	PHEO	CHLA
					_ML	CODE	CM	_L	B	B	B	B	B	B	B		
CB5.2	3-460	1	S	0.5	14		5	0.50	0.038	0.035	0.039	0.135	0.136	0.085	0.005	0.005	0.007.626
CB5.2	3-460	2	S	0.5	14		5	0.50	0.037	0.035	0.039	0.132	0.132	0.082	0.005	0.005	0.007.476
CB5.3	3-460	1	S	0.5	14		5	0.50	0.056	0.052	0.059	0.210	0.210	0.128	0.006	0.005	0.000.359
CB5.3	3-460	1	AP	9	14		5	0.50	0.058	0.054	0.062	0.218	0.218	0.134	0.007	0.007	0.000.733
CB5.3	3-460	1	BP	19	14		5	0.40	0.042	0.039	0.045	0.152	0.152	0.098	0.005	0.005	0.002.075
CB5.3	3-460	1	B	26	14		5	0.40	0.047	0.045	0.051	0.169	0.169	0.115	0.008	0.006	0.003.532
LE2.3	3-460	1	S	0.5	14		5	0.50	0.052	0.048	0.054	0.192	0.192	0.117	0.006	0.006	0.000.404
LE2.3	3-460	1	AP	7	14		5	0.50	0.069	0.064	0.073	0.263	0.264	0.160	0.007	0.005	0.000.164
LE2.3	3-460	1	BP	13	14		5	0.40	0.059	0.054	0.062	0.227	0.227	0.136	0.005	0.005	0.000.131
LE2.3	3-460	1	B	19	14		5	0.40	0.121	0.106	0.120	0.432	0.434	0.272	0.007	0.006	0.004.205

Appendix XII. Sample Verification Reports and Plots and Edit Form

Maryland Department of Natural Resources

Lab Sheet

Station Name	Project	Sample Date	Arrival Time	Sample Depth	Layer Code	Replicate Number	Sample Number	Sequence Number
CB5.3	MAIN	2/7/2006	10:55	0.5	S	1	4	200602070001

Sample Description :

LAB Description :

Parameters	Type	Method Code	APC Code	DL	Value	Visible	Enabled	Pseudo	Calculated
NH4	F	L01		<	0.003	<input checked="" type="checkbox"/>	<input checked="" type="checkbox"/>	<input checked="" type="checkbox"/>	<input type="checkbox"/>
NO2	F	L01			0.0063	<input checked="" type="checkbox"/>	<input checked="" type="checkbox"/>	<input type="checkbox"/>	<input type="checkbox"/>
NO23	F	L01			0.156	<input checked="" type="checkbox"/>	<input checked="" type="checkbox"/>	<input type="checkbox"/>	<input type="checkbox"/>
PC	N	L01			1.14	<input checked="" type="checkbox"/>	<input checked="" type="checkbox"/>	<input type="checkbox"/>	<input type="checkbox"/>
PN	N	L01			0.18	<input checked="" type="checkbox"/>	<input checked="" type="checkbox"/>	<input type="checkbox"/>	<input type="checkbox"/>
PO4	F	L01			0.002	<input checked="" type="checkbox"/>	<input checked="" type="checkbox"/>	<input type="checkbox"/>	<input type="checkbox"/>
PP	N	L01			0.0099	<input checked="" type="checkbox"/>	<input checked="" type="checkbox"/>	<input type="checkbox"/>	<input type="checkbox"/>
SI	F	L01			0.4	<input checked="" type="checkbox"/>	<input checked="" type="checkbox"/>	<input type="checkbox"/>	<input type="checkbox"/>
TDN	N	L01			0.5	<input checked="" type="checkbox"/>	<input checked="" type="checkbox"/>	<input type="checkbox"/>	<input type="checkbox"/>
TDP	N	L01			0.0086	<input checked="" type="checkbox"/>	<input checked="" type="checkbox"/>	<input type="checkbox"/>	<input type="checkbox"/>
TSS	N	L01			3.7	<input checked="" type="checkbox"/>	<input checked="" type="checkbox"/>	<input type="checkbox"/>	<input type="checkbox"/>

Actual Parameters	Type	Method Code	APC Code	DL	Value	Visible	Enabled	Pseudo	Calculated
NH4	F	L01		<	0.001	<input type="checkbox"/>	<input checked="" type="checkbox"/>	<input type="checkbox"/>	<input type="checkbox"/>

Tuesday, March 28, 2006
Analysis Agency DNR/TEA
Analysis Officer DNR/SAB
Page 1 of 58

Appendix XII. Sample Verification Reports and Plots and Edit Form

CHLA_N RESULTS FOR CRUISE 200602A
Chesapeake Bay Sampling Event

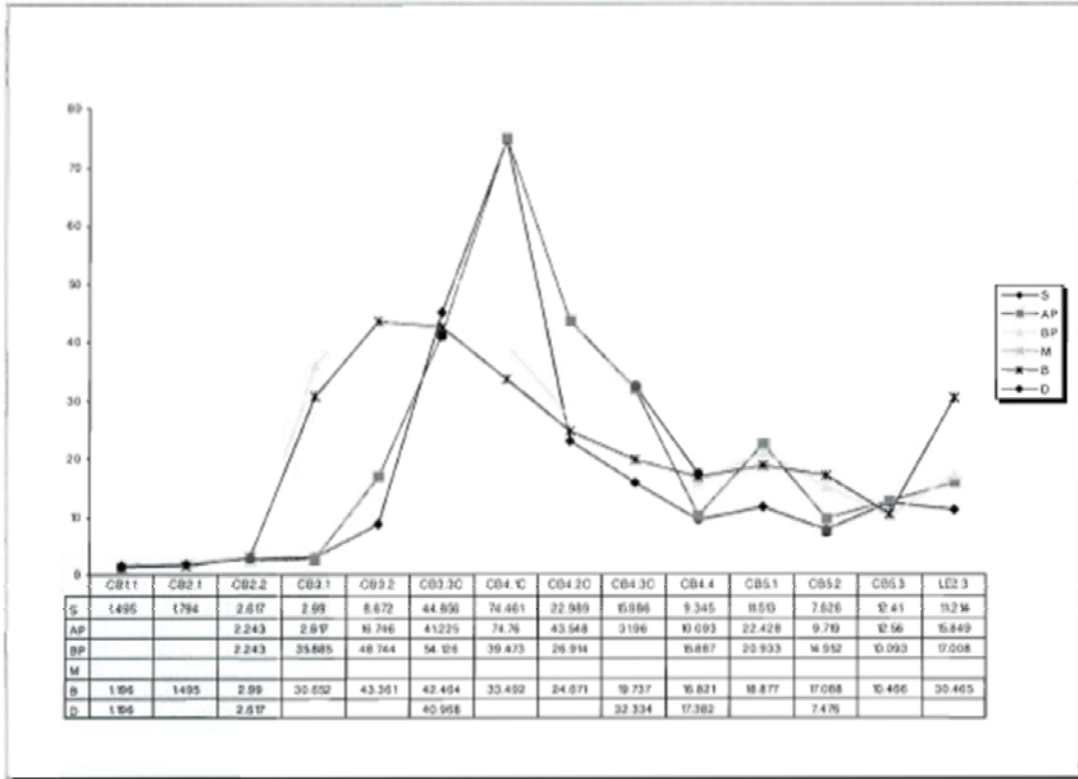

WQ Plot System v1.0 Written By Tyrone W. Lee
(c) 2002 DNR/TEA

Appendix XII. Sample Verification Reports and Plots and Edit Form

DO_N RESULTS FOR CRUISE 200602A
Chesapeake Bay Sampling Event

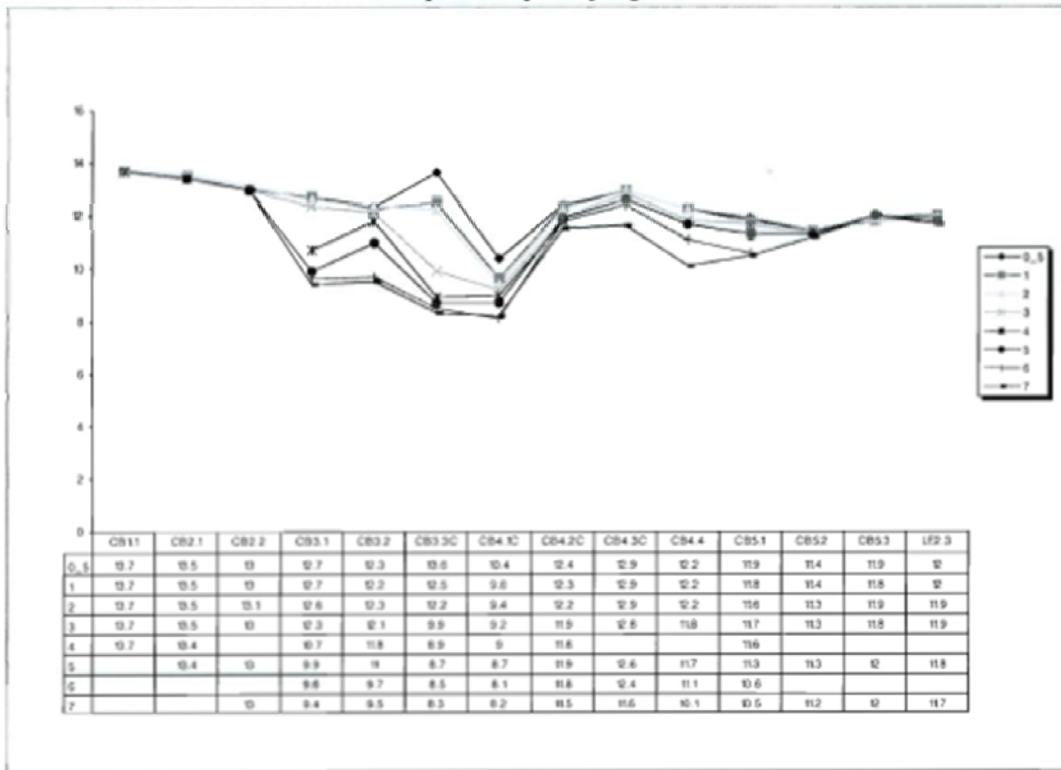

WQ Plot System v1.0 Written By Tyrone W. Lee
 (c) 2002 DNR/TEA

Appendix XII. Sample Verification Reports and Plots and Edit Form

NH4_F RESULTS FOR CRUISE 200602A
Chesapeake Bay Sampling Event

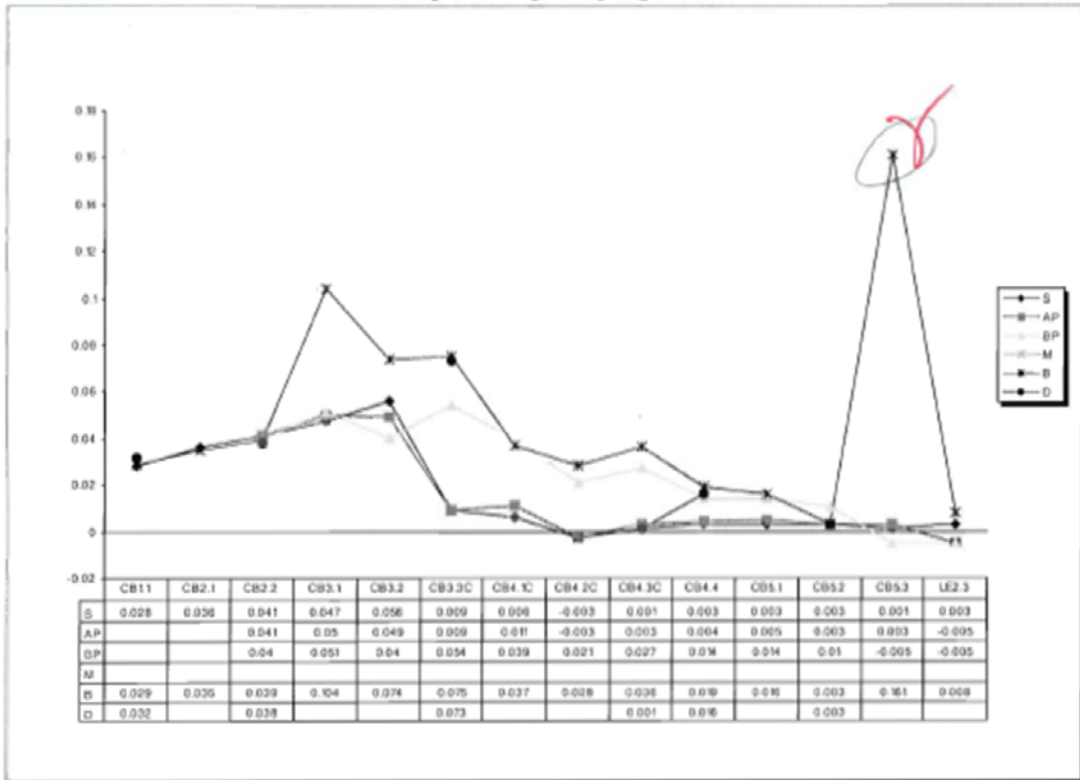

WQ Plot System v1.0 Written By Tyrone W. Lee
(c) 2002 DNR/TEA

Appendix XII. Sample Verification Reports and Plots and Edit Form

0600206	CB4.3C	MAIN	200602A	2/8/2006	0.5	S	1			EQ_NUM
0600207	CB4.2C	MAIN	200602A	2/8/2006	0.5	S	1			EQ_NUM
0600208	CB4.1C	MAIN	200602A	2/8/2006	0.5	S	1			EQ_NUM
0600209	CB3.3C	MAIN	200602A	2/8/2006	0.5	S	1			EQ_NUM
0600210	CB3.2	MAIN	200602A	2/8/2006	0.5	S	1			EQ_NUM
0600211	CB3.1	MAIN	200602A	2/9/2006	0.5	S	1			EQ_NUM
0600212	CB2.2	MAIN	200602A	2/9/2006	0.5	S	1			EQ_NUM
0600213	CB2.1	MAIN	200602A	2/9/2006	0.5	S	1			EQ_NUM
0600214	CB1.1	MAIN	200602A	2/9/2006	0.5	S	1			EQ_NUM

Column Check: Parameter Values are falling outside of a reasonable range

Field Seq No	StationName	Project Code	SampleDate	Depth	Layer	Rep. No	Parameter	Value	Lower DL	Upper DL
0600201	CB5.3	MAIN	2/7/2006	0.5	S	1	WTEMP	5.7 ✓	-0.5	5
0600201	CB5.3	MAIN	2/7/2006	1	M	1	WTEMP	5.7 ✓	-0.5	5
0600201	CB5.3	MAIN	2/7/2006	2	M	1	WTEMP	5.7 ✓	-0.5	5
0600201	CB5.3	MAIN	2/7/2006	3	M	1	WTEMP	5.7 ✓	-0.5	5
0600201	CB5.3	MAIN	2/7/2006	5	M	1	WTEMP	5.6 ✓	-0.5	5
0600201	CB5.3	MAIN	2/7/2006	7	M	1	WTEMP	5.6 ✓	-0.5	5
0600201	CB5.3	MAIN	2/7/2006	9	AP	1	WTEMP	5.6 ✓	-0.5	5
0600201	CB5.3	MAIN	2/7/2006	10	M	1	WTEMP	5.6 ✓	-0.5	5
0600201	CB5.3	MAIN	2/7/2006	11	M	1	WTEMP	5.8 ✓	-0.5	5
0600201	CB5.3	MAIN	2/7/2006	12	M	1	WTEMP	5.9 ✓	-0.5	5
0600201	CB5.3	MAIN	2/7/2006	13	M	1	WTEMP	5.9 ✓	-0.5	5
0600201	CB5.3	MAIN	2/7/2006	14	M	1	WTEMP	5.9 ✓	-0.5	5
0600201	CB5.3	MAIN	2/7/2006	15	M	1	WTEMP	5.9 ✓	-0.5	5
0600201	CB5.3	MAIN	2/7/2006	16	M	1	WTEMP	5.9 ✓	-0.5	5
0600201	CB5.3	MAIN	2/7/2006	17	M	1	WTEMP	5.9 ✓	-0.5	5
0600201	CB5.3	MAIN	2/7/2006	18	M	1	WTEMP	6 ✓	-0.5	5
0600201	CB5.3	MAIN	2/7/2006	19	BP	1	WTEMP	6 ✓	-0.5	5
0600201	CB5.3	MAIN	2/7/2006	21	M	1	WTEMP	6.1 ✓	-0.5	5
0600201	CB5.3	MAIN	2/7/2006	23	M	1	WTEMP	6.1 ✓	-0.5	5

Page 3 of 10

Column Check: Parameter APCodes might not appropriate and need to verify

Chi Seq No	StationName	Project Code	Cruise Name	SampleDate	Depth	Layer	Rep. #	Parameter	Value	Problem
3-460B	CB4.3C	MAIN	200602A	2/8/2006	13	BP	1	CHLA	0	A
3-460B	CB4.3C	MAIN	200602A	2/8/2006	13	BP	1	EXVOL_ML	14	A
3-460B	CB4.3C	MAIN	200602A	2/8/2006	13	BP	1	LIPAT_CM	5	A
3-460B	CB4.3C	MAIN	200602A	2/8/2006	13	BP	1	OD630B	0.127	A
3-460B	CB4.3C	MAIN	200602A	2/8/2006	13	BP	1	OD645B	0.107	A
3-460B	CB4.3C	MAIN	200602A	2/8/2006	13	BP	1	OD647B	0.121	A
3-460B	CB4.3C	MAIN	200602A	2/8/2006	13	BP	1	OD663B	0.437	A

2005 CMON - May

Field (see changes written on sheets)

- Sequence Number: RHO0521 (Page 68 of 79)
- No Plots For:
 - Cruise D - Eastern Shore: EPAR_S_N
 - Cruise D - Potomac River: EPAR_U_Z_N
 - Cruise D - RWS: SALINITY_N
 - Cruise D - Western Shore: SALINITY_N
 - Cruise D - Western Shore: SALINITY_FLD_N

Laboratory (see changes written on sheets)

- Sequence Number: 200505100832 (Page 29 of 83)
- Sequence Number: 200505170852 (Page 45 of 83)
- Sequence Number: 200505240100 (Page 59 of 83)
- Sequence Number: 200505240101 (Page 60 of 83)
- Sequence Number: 200505240102 (Page 61 of 83)
- Sequence Number: 200505310103 (Page 77 of 83)

APPENDIX XIII

CHESAPEAKE BAY MONITORING PROGRAM PROCEDURE MODIFICATION TRACKING FORM

PMTF # _____

APPROVED DENIED

This form is used to request approval for modifications and to document approved modifications made to Chesapeake Bay Program Office procedures or methods. It is not a substitute for timely contact with the CBPO Quality Assurance Officer or his/her designee, who may be reached at 1-800-968-7229. A detailed method description including the proposed modification must be attached to this form prior to submittal to CBPO.

DATE SUBMITTED	DATE APPROVED
REQUESTOR NAME	ORGANIZATION
NEWLY PROPOSED [] MODIFICATION	FIELD-APPROVED [] MODIFICATION
APPROVED BY: DATE:	
TYPE OF PROCEDURE / METHOD	SAMPLING [] ANALYTICAL [] REPORTING []
	FIELD [] MEASUREMENT OTHER [] SPECIFY:
DURATION	PERMANENT [] EFFECTIVE DATE: TEMPORARY [] START DATE: END DATE:
PROCEDURE/METHOD DESCRIPTION	
MODIFICATION DESCRIPTION	
JUSTIFICATION FOR MODIFICATION	
ANALYTICAL PARAMETERS THAT MAY BE AFFECTED BY THIS CHANGE	
AFFECTED QA PLAN(S) (TITLE, REVISION, & DATE)	
AFFECTED CRUISE(S)	
PMTF COMPLETED BY	NAME: _____ DATE: _____

STATE APPROVAL: NAME _____ TITLE _____
SIGNATURE _____ DATE _____

CBPO APPROVAL: NAME _____ TITLE _____
SIGNATURE _____ DATE _____

APPENDIX XIV

MARYLAND DEPARTMENT OF NATURAL RESOURCES CHESAPEAKE BAY WATER QUALITY MONITORING PROGRAM

Log of Significant Changes

Date Initiated	Procedural Changes
See Tables 1-6 at the end of this Log	<p>NOTE Changes in Measured Parameters and in Detection Limits are detailed in the following tables:</p> <ul style="list-style-type: none">• Table 1 - Tributary Detection Limit• Table 2 - Patuxent Detection Limits• Table 3 - Potomac Detection Limits• Table 4 - LE2.3 and Mainstem Detection Limits.• Table 5 - Light Attenuation - Mainstem and Patuxent Sampling Sites and Dates• Table 6 - Light Attenuation - Other Maryland Tributaries Sampling Sites and Dates
March 1, 1985	The EPA Central Regional Laboratory (CRL) in Annapolis processed Mainstem cruises water quality samples collected in July-December of 1984. CRL processed most Mainstem samples in 1985 and 1986. However the beginning 1-Mar-1985 Chesapeake Biological Laboratory began analysis of dissolved constituents (Si, DOC, TDN and TDP). In May of 1987 water quality lab work was switched to Chesapeake Biological Laboratory
May 1, 1987	
April 1, 1989	Dropped Patuxent River station XCG8613
July 1, 1990	Nutrient analysis of Patuxent River samples switched from State lab at Department of Health and Mental Hygiene (DHMH) to University of Maryland Chesapeake Biological Laboratory
October 1, 1990	Switch to filtering samples for PO ₄ , NH ₄ , NO ₂ , NO ₃ in Potomac instead of analyzing whole water sample
December 10, 1990	A data quality assurance issue titled "Adjusting Maryland Department of Health and Mental Hygiene (MDHMH) total phosphorus (TP) and total dissolved phosphorus (TDP) data," was entered into the Data Analysis Issues Tracking System 10-Dec-1990. MDHMH was not using calibration data or blank data in calculating TP and TDP from 1984 through 1989. Most of the

Date Initiated**Procedural Changes**

	<p>data affected by this problem were re-calibrated and re-submitted to the Chesapeake Bay Program. Samples analyzed in 1984 were not re-calculated. Some samples analyzed between 1985 and 1990 were also not re-calibrated due to missing blank data and other problems. As a result, there may be a mix of uncorrected and corrected TP and TDP data in the data base.</p>
January 28, 1992	<p>A report titled “Adjusting helix Kjeldahl nitrogen results: Maryland Chesapeake Bay mainstem water quality monitoring program, 1984-1985” was produced by Computer Sciences Corporation under contract to the U.S. Environmental Protection Agency, contract number 68-WO-0043. The report examined the effects of helix digestion on Kjeldahl nitrogen, which is biased low relative to other digestion methods, and presented the equations used to adjust 1984 and 1985 data. The report was approved by Chesapeake Bay Program Analytical Methods and Quality Assurance Workgroup 12-Nov-1991 and by the Chesapeake Bay Program Monitoring Subcommittee 22-Jan-1992.</p>
January 1996	<p>TOC and DOC was dropped from Mainstem sampling</p>
May 1, 1998	<p>Nutrient analysis of Potomac and Minor Tributary samples switched from State lab at Department of Health and Mental Hygiene (DHMH) to University of Maryland Chesapeake Biological Laboratory</p>
March 2003	<p>Addition of ten new long-term stations previously part of the <i>Pfiesteria</i> special project sampling BXK0031, CCM0069, MNK0146, POK0087, TRQ0088, TRQ0146, WIW0141, XAK7810, XCI4078, XDJ9007</p>
July 1, 2005	<p>Sampling TF1.0 on the Patuxent was dropped from the CORE/Trend program, which had samples analyzed at DHMH. The station is now sampled only under the Patuxent tributary program, which has samples analyzed at CBL</p>
January 2007	<p>Starting in July, 2007, silica (SIF) will no longer be collected at any of the mainstem stations during the months of July-December, and will only be collected from the surface layer at the five mainstem stations that correspond with phytoplankton program sampling (CB1.1, CB2.2, CB3.3C, CB4.3C and CB5.2) in the months January-June. Tributary collection of silica samples will also change, beginning July, 2007, as</p>

Date Initiated	Procedural Changes
January 2009	<p>follows: no samples July-December, and silica only from surface sample at the following stations January-June: TF2.3, RET2.2, LE2.2, TF1.5, TF1.7, LE1.1, ET5.1, WT5.1.</p> <p>Beginning in January 2009, chlorophyll analysis by the Maryland Department of Health and Mental Hygiene ceased and the Chesapeake Bay Laboratory, Nutrient Analytical Services Laboratory began analyzing chlorophyll samples.</p>
January 2009	<p>NO₂ detection limit change: was 0.0006 mg/L, updated to 0.0001 mg/L</p>
January 2009	<p>NH₄ detection limit change: was 0.003 mg/L updated to 0.006 mg/L</p>
February 2009	<p>Beginning in February 2009, YSI Series 6820 instruments were added to the field instrument inventory. YSI instruments are equipped with an optical dissolved oxygen sensor (ROX) instead of the Standard Clark Polarographic Sensor. Temperature, pH, specific conductance and depth sensors perform similarly to respective Hydrolab sensors.</p> <p>Both the Hydrolab and YSI optical dissolved oxygen sensors use similar luminescent technology and phase shift techniques to measure dissolved oxygen.</p> <p>Mainstem and Patuxent River cruises will exclusively use YSI instead of Hydrolab instruments. All tributary sampling activities will use either Hydrolab or YSI instruments.</p>
January 2010	<p>Mainstem stations: CB3.3 E CB3.3W, CB4.1E, CB4.1W, CB4.2E, CB4.2W, CB4.3E, CB4.3W will be sampled 10 times per year instead of 12 times per year.</p> <p>Patuxent River stations: CB5.1W, LE1.1, LE1.2, LE1.3, LE1.4, RET1.1, TF1.0, TF1.2, TF1.3, TF1.4, TF1.5, TF1.6, TF1.7 and WXT0001 will be sampled 12 times per year instead of 20 times per year.</p> <p>Potomac River stations: LE2.2, MAT0016, MAT0078, PIS0033, RET2.1, RET2.2, RET2.4, TF2.1, TF2.2, TF2.3, TF2.4 and XFB1986 will be sampled 12 times per year instead of 20 times per year. Potomac River station: LE2.3, which is sampled on Mainstem cruises, will be sampled 12 times per year instead of 20 times per year.</p>

Date Initiated	Procedural Changes
	Chester River stations: ET4.1 and ET4.2 and Choptank River stations: ET5.1 and ET5.2 and station WT4.1 in the Back River will be sampled 12 times per year instead of 16 times per year.
January 2011	CBL NASL NO ₂ detection limit change: was 0.0001 mg/L, updated to 0.0002 mg/L
January 2011	CBL NASL NH ₄ detection limit change: was 0.006 mg/L updated to 0.001 mg/L
January 2012	CBL NASL NO ₂ detection limit change: was 0.0002 mg/L, updated to 0.0007 mg/L
January 2012	CBL NASL SI detection limit change: was 0.01 mg/L, updated to 0.06 mg/L
January 2013	CBL NASL SI detection limit change: was 0.06 mg/L, updated to 0.002 mg/L
January 2014	CBL NASL SI detection limit change: was 0.002 mg/L, updated to 0.01 mg/L
January 2014	Due to funding cutbacks sample collection ended at nine tributary stations in December 2013, Chicamacomico River: CCM0069; Manokin River: BXK0031, MNK0146; Nanticoke River: XDJ9007; Pocomoke River: POK0087, XAK7810; Transquaking River: TRQ0088, TRQ0146; and Wicomico River: XCI4078.
January 2016	CBL NASL PP detection limit change: was 0.0021 mg/L, updated to 0.0035 mg/L
December 2016	Table 5 – Light Attenuation - Sampling Sites and Dates – Mainstem and Patuxent R.
December 2016	Table 6 – Light Attenuation - Sampling Sites and Dates – Other MD Tributaries – Data not collected or submitted by MD DNR
January 2017	CBL NASL Si detection limit change: was 0.01 mg/L, updated to 0.0536 mg/L

Tributary	Detection Limits																				
Censor is to 1/2 DL	Red Boldface shows when DL changed																				
Calculated	Values																				
lab	DHMH	DHMH	DHMH	DHMH	DHMH	DHMH	CBL	CBL	CBL	CBL	CBL	CBL	CBL	CBL	CBL	CBL	CBL	CBL	CBL	CBL	
parameter	1/1/85-5/31/86	6/1/86-12/31/88	1/1/89-4/30/90	5/1/90-6/30/94	7/1/94-7/12/95	7/13/95-4/30/98	5/1/98-12/31/99	1/1/00-12/31/03	1/1/04-12/31/05	1/1/06-12/31/06	1/1/07-12/31/07	1/1/08-12/31/08	1/1/09-12/31/09	1/1/10-12/31/10	1/1/11-12/31/11	1/1/12-12/31/12	1/1/13-12/31/13	1/1/14-12/31/15	1/1/16-12/31/16	1/1/17-12/31/17	
CHLA	DHMH did Chlorophylls until December 2008; no DL were determined												0.62	0.62	0.62	0.62	0.62	0.62	0.62	0.62	0.62
DIN	0.04	0.028	0.028	0.028	0.028	0.01	0.0032	0.0037	0.0037	0.0037	0.0037	0.0037	0.0037	0.0067	0.0067	0.0017	0.0017	0.0017	0.0017	0.0017	0.0017
DOC	1	1	0.8	0.5	0.5	0.5	0.24	0.24	0.15	0.15	0.24	0.24	0.24	0.24	0.24	0.24	0.24	0.24	0.24	0.24	0.24
DON	0.08	0.092	0.092	0.092	0.092	0.092	0.0168	0.0163	0.0163	0.0163	0.0163	0.0463	0.0433	0.0433	0.0483	0.0483	0.0483	0.0483	0.0483	0.0483	0.0483
DOP	0	0.006	0.006	0.006	0.006	0.006	0.0004	0.0004	0.0004	0.0009	0.0009	0.0009	0.0009	0.0009	0.0009	0.0009	0.0009	0.0009	0.0009	0.0009	0.0009
NH4	0.02	0.008	0.008	0.008	0.008	0.008	0.003	0.003	0.003	0.003	0.003	0.003	0.003	0.006	0.006	0.001	0.001	0.001	0.001	0.001	0.001
NO2	0.002	0.002	0.002	0.002	0.002	0.002	0.0002	0.0002	0.0002	0.0002	0.0006	0.0006	0.0001	0.0006	0.0002	0.0007	0.0007	0.0007	0.0007	0.0007	0.0007
NO23	0.02	0.02	0.02	0.02	0.02	0.02	0.0002	0.0007	0.0007	0.0007	0.0007	0.0007	0.0007	0.0007	0.0007	0.0007	0.0007	0.0007	0.0007	0.0007	0.0007
PC	0	0	0	0	0	0	0.0633	0.0633	0.0633	0.0759	0.0633	0.0633	0.0633	0.0633	0.0633	0.0633	0.0633	0.0633	0.0633	0.0633	0.0633
PHEO	DHMH did Pheopigments until December 2008; no DL were determined												0.74	0.74	0.74	0.74	0.74	0.74	0.74	0.74	0.74
PN	0	0	0	0	0	0	0.0105	0.0105	0.0105	0.0105	0.0105	0.0105	0.0105	0.0105	0.0105	0.0105	0.0105	0.0105	0.0105	0.0105	0.0105
PO4	0.01	0.004	0.004	0.004	0.004	0.004	0.0006	0.0006	0.0006	0.0006	0.0006	0.0006	0.0006	0.0006	0.0006	0.0006	0.0006	0.0006	0.0006	0.0006	0.0006
PP	0	0	0	0	0	0	0.0012	0.0024	0.0024	0.0024	0.0054	0.0021	0.0021	0.0021	0.0021	0.0021	0.0021	0.0021	0.0021	0.0035	0.0035
SI	0.1	0.1	0.1	0.1	0.1	0.1	0.01	0.01	0.01	0.01	0.01	0.08	0.01	0.01	0.01	0.06	0.0022	0.01	0.01	0.0536	0.0536
TDN	0.08	0.12	0.12	0.12	0.12	0.102	0.02	0.02	0.02	0.02	0.02	0.05	0.05	0.05	0.05	0.05	0.05	0.05	0.05	0.05	0.05
TDP	0.01	0.01	0.01	0.01	0.01	0.01	0.001	0.001	0.001	0.0015	0.0015	0.0015	0.0015	0.0015	0.0015	0.0015	0.0015	0.0015	0.0015	0.0015	0.0015
TKNF	0.1	0.1	0.1	0.1	0.1	0.1															
TKNW	0.1	0.1	0.1	0.1	0.1	0.1															
TN	0.12	0.12	0.12	0.12	0.12	0.102	0.0305	0.0305	0.0305	0.0305	0.0305	0.0605	0.0605	0.0605	0.0605	0.0605	0.0605	0.0605	0.0605	0.0605	0.0605
TOC	1	1	0.8	0.5	0.5	0.5	0.3033	0.3033	0.2133	0.2259	0.3033	0.3033	0.3033	0.3033	0.3033	0.3033	0.3033	0.3033	0.3033	0.3033	0.3033
TON	0.08	0.092	0.092	0.092	0.092	0.092	0.0273	0.0268	0.0268	0.0268	0.0268	0.0568	0.0538	0.0538	0.0588	0.0588	0.0588	0.0588	0.0588	0.0588	0.0588
TOP	0	0.006	0.006	0.006	0.006	0.006	0.0016	0.0028	0.0028	0.0033	0.0063	0.003	0.003	0.003	0.003	0.003	0.003	0.003	0.003	0.0044	0.0044
TP	0.01	0.01	0.01	0.01	0.01	0.01	0.0022	0.0034	0.0034	0.0039	0.0069	0.0036	0.0036	0.0036	0.0036	0.0036	0.0036	0.0036	0.0036	0.005	0.005
TSS	1	1	1	1	1	1	1.5	2.4	2.4	2.4	2.4	2.4	2.4	2.4	2.4	2.4	2.4	2.4	2.4	2.4	2.4
VSS							1.98	1.98	1.98	0.9	0.9	0.9	0.9	0.9	0.9	0.9	0.9	0.9	0.9	0.9	0.9

Table 1 Tributary Detection Limits

Patuxent Detection Limits																			
Censor is to 1/2 DL Red Boldface shows when DL changed																			
Calculated Values																			
Patuxent doesn't need Water year censored datasets because all stations started in early 1985																			
parameter	DHMH 1/1/85-5/31/86	DHMH 6/1/86-12/31/88	DHMH 1/1/89-4/30/90	DHMH 5/1/90-8/30/90	CBL 7/1/90-12/31/99	CBL 1/1/00-12/31/03	CBL 1/1/04-12/31/05	CBL 1/1/06-12/31/06	CBL 1/1/07-12/31/07	CBL 1/1/08-12/31/08	CBL 1/1/09-12/31/09	CBL 1/1/10-12/31/10	CBL 1/1/11-12/31/11	CBL 1/1/12-12/31/12	CBL 1/1/13-12/31/13	CBL 1/1/14-12/31/15	CBL 1/1/16-12/31/16	CBL 1/1/17-12/31/17	
CHLA	DHMH did Chlorophylls until December 2008; no DL were determined																		
DIN	0.04	0.03	0.028	0.028	0.0032	0.0037	0.0037	0.0037	0.0037	0.0037	0.0067	0.0067	0.0017	0.0017	0.0017	0.0017	0.0017	0.0017	
DOC	1	1	0.8	0.5	0.24	0.24	0.15	0.15	0.24	0.24	0.24	0.24	0.24	0.24	0.24	0.24	0.24	0.24	
DON	0.08	0.09	0.092	0.092	0.0168	0.0163	0.0163	0.0163	0.0163	0.0463	0.0433	0.0433	0.0483	0.0483	0.0483	0.0483	0.0483	0.0483	
DDP	0	0.01	0.006	0.006	0.0004	0.0004	0.0004	0.0009	0.0009	0.0009	0.0009	0.0009	0.0009	0.0009	0.0009	0.0009	0.0009	0.0009	
NH4	0.02	0.01	0.008	0.008	0.003	0.003	0.003	0.003	0.003	0.003	0.006	0.006	0.001	0.001	0.001	0.001	0.001	0.001	
NO2	0.002	0.002	0.002	0.002	0.0002	0.0002	0.0002	0.0002	0.0006	0.0006	0.0001	0.0006	0.0002	0.0007	0.0007	0.0007	0.0007	0.0007	
NO23	0.02	0.02	0.02	0.02	0.0002	0.0007	0.0007	0.0007	0.0007	0.0007	0.0007	0.0007	0.0007	0.0007	0.0007	0.0007	0.0007	0.0007	
PC	0	0	0	0	0.0633	0.0633	0.0633	0.0759	0.0633	0.0633	0.0633	0.0633	0.0633	0.0633	0.0633	0.0633	0.0633	0.0633	
PHEO	DHMH did Pheopigments until December 2008; no DL were determined																		
PN	0	0	0	0	0.0105	0.0105	0.0105	0.0105	0.0105	0.0105	0.0105	0.0105	0.0105	0.0105	0.0105	0.0105	0.0105	0.0105	
PO4	0.01	0	0.004	0.004	0.0006	0.0006	0.0006	0.0006	0.0006	0.0006	0.0006	0.0006	0.0006	0.0006	0.0006	0.0006	0.0006	0.0006	
PP	0	0	0	0	0.0012	0.0024	0.0024	0.0024	0.0054	0.0021	0.0021	0.0021	0.0021	0.0021	0.0021	0.0021	0.0035	0.0035	
SI	0.1	0.1	0.1	0.1	0.01	0.01	0.01	0.01	0.08	0.01	0.01	0.01	0.01	0.06	0.0022	0.01	0.01	0.0536	
TDN	0.08	0.12	0.12	0.12	0.02	0.02	0.02	0.02	0.02	0.05	0.05	0.05	0.05	0.05	0.05	0.05	0.05	0.05	
TDP	0.01	0.01	0.01	0.01	0.001	0.001	0.001	0.0015	0.0015	0.0015	0.0015	0.0015	0.0015	0.0015	0.0015	0.0015	0.0015	0.0015	
TKNF	0.1	0.1	0.1	0.1															
TKNW	0.1	0.1	0.1	0.1															
TN	0.12	0.12	0.12	0.12	0.0305	0.0305	0.0305	0.0305	0.0305	0.0605	0.0605	0.0605	0.0605	0.0605	0.0605	0.0605	0.0605	0.0605	
TOC	1	1	0.8	0.5	0.3033	0.3033	0.2133	0.2259	0.3033	0.3033	0.3033	0.3033	0.3033	0.3033	0.3033	0.3033	0.3033	0.3033	
TON	0.08	0.09	0.092	0.092	0.0273	0.0268	0.0268	0.0268	0.0268	0.0568	0.0538	0.0538	0.0588	0.0588	0.0588	0.0588	0.0588	0.0588	
TOP	0	0.01	0.006	0.006	0.0016	0.0028	0.0028	0.0033	0.0063	0.003	0.003	0.003	0.003	0.003	0.003	0.003	0.0044	0.0044	
TP	0.01	0.01	0.01	0.01	0.0022	0.0034	0.0034	0.0039	0.0069	0.0036	0.0036	0.0036	0.0036	0.0036	0.0036	0.0036	0.005	0.005	
TSS	1	1	1	1	1.5	2.4	2.4	2.4	2.4	2.4	2.4	2.4	2.4	2.4	2.4	2.4	2.4	2.4	
VSS					1.98	1.98	1.98	0.9	0.9	0.9	0.9	0.9	0.9	0.9	0.9	0.9	0.9	0.9	

Table 2 Patuxent Detection Limits

Potomac Detection Limits																					
Censor is to 1/2 DL Red Boldface shows when DL changed																					
Calculated Values																					
Potomac doesn't need Water year censored datasets because all stations started in early 1985 EXCEPT LE2.3 because uses CBL detection limits!																					
PO4 prior to 10/90 is not used in trends																					
parameter	DHMH 1/1/85-5/31/86	DHMH 6/1/86-12/31/88	DHMH 1/1/89-4/30/90	DHMH 5/1/90-6/30/94	DHMH 7/1/94-7/12/95	DHMH 7/13/95-4/30/98	CBL 5/1/98-12/31/99	CBL 1/1/00-12/31/03	CBL 1/1/04-12/31/05	CBL 1/1/06-12/31/06	CBL 1/1/07-12/31/07	CBL 1/1/08-12/31/08	CBL 1/1/09-12/31/09	CBL 1/1/10-12/31/10	CBL 1/1/11-12/31/11	CBL 1/1/12-12/31/12	CBL 1/1/13-12/31/13	CBL 1/1/14-12/31/15	CBL 1/1/16-12/31/16	CBL 1/1/17-12/31/17	
CHLA	DHMH did Chlorophylls until December 2008; no DL were determined													0.62	0.62	0.62	0.62	0.62	0.62	0.62	0.62
DIN	0.04	0.03	0.028	0.028	0.028	0.01	0.0032	0.0037	0.0037	0.0037	0.0037	0.0037	0.0017	0.0017	0.0017	0.0017	0.0017	0.0017	0.0017	0.0017	0.0017
DOC	1	1	0.8	0.5	0.5	0.5	0.24	0.24	0.15	0.15	0.24	0.24	0.24	0.24	0.24	0.24	0.24	0.24	0.24	0.24	0.24
DON	0.08	0.09	0.092	0.092	0.092	0.092	0.0168	0.0163	0.0163	0.0163	0.0163	0.0463	0.0483	0.0483	0.0483	0.0483	0.0483	0.0483	0.0483	0.0483	0.0483
DOP	0	0.01	0.006	0.006	0.006	0.006	0.0004	0.0004	0.0004	0.0009	0.0009	0.0009	0.0009	0.0009	0.0009	0.0009	0.0009	0.0009	0.0009	0.0009	0.0009
NH4	0.02	0.01	0.008	0.008	0.008	0.008	0.003	0.003	0.003	0.003	0.003	0.003	0.001	0.001	0.001	0.001	0.001	0.001	0.001	0.001	0.001
NO2	0.002	0.002	0.002	0.002	0.002	0.002	0.0002	0.0002	0.0002	0.0002	0.0006	0.0006	0.0007	0.0007	0.0007	0.0007	0.0007	0.0007	0.0007	0.0007	0.0007
NO23	0.02	0.02	0.02	0.02	0.02	0	0.0002	0.0007	0.0007	0.0007	0.0007	0.0007	0.0007	0.0007	0.0007	0.0007	0.0007	0.0007	0.0007	0.0007	0.0007
PC	0	0	0	0	0	0	0.0633	0.0633	0.0633	0.0759	0.0633	0.0633	0.0633	0.0633	0.0633	0.0633	0.0633	0.0633	0.0633	0.0633	0.0633
PHEO	DHMH did Pheopigments until December 2008; no DL were determined													0.74	0.74	0.74	0.74	0.74	0.74	0.74	0.74
PN	0	0	0	0	0	0	0.0105	0.0105	0.0105	0.0105	0.0105	0.0105	0.0105	0.0105	0.0105	0.0105	0.0105	0.0105	0.0105	0.0105	0.0105
PO4	0.01	0	0.004	0.004	0.004	0.004	0.0006	0.0006	0.0006	0.0006	0.0006	0.0006	0.0006	0.0006	0.0006	0.0006	0.0006	0.0006	0.0006	0.0006	0.0006
PP	0	0	0	0	0	0	0.0012	0.0024	0.0024	0.0024	0.0054	0.0021	0.0035	0.0035	0.0035	0.0035	0.0035	0.0035	0.0035	0.0035	0.0035
SI	0.1	0.1	0.1	0.1	0.1	0.1	0.01	0.01	0.01	0.01	0.08	0.01	0.01	0.01	0.01	0.01	0.01	0.01	0.01	0.01	0.0536
TDN	0.08	0.12	0.12	0.12	0.12	0.1	0.02	0.02	0.02	0.02	0.02	0.05	0.05	0.05	0.05	0.05	0.05	0.05	0.05	0.05	0.05
TDP	0.01	0.01	0.01	0.01	0.01	0.01	0.001	0.001	0.001	0.0015	0.0015	0.0015	0.0015	0.0015	0.0015	0.0015	0.0015	0.0015	0.0015	0.0015	0.0015
TKNF	0.1	0.1	0.1	0.1	0.1	0.1															
TKNW	0.1	0.1	0.1	0.1	0.1	0.1															
TN	0.12	0.12	0.12	0.12	0.12	0.1	0.0305	0.0305	0.0305	0.0305	0.0305	0.0605	0.0605	0.0605	0.0605	0.0605	0.0605	0.0605	0.0605	0.0605	0.0605
TOC	1	1	0.8	0.5	0.5	0.5	0.3033	0.3033	0.2133	0.2259	0.3033	0.3033	0.3033	0.3033	0.3033	0.3033	0.3033	0.3033	0.3033	0.3033	0.3033
TON	0.08	0.09	0.092	0.092	0.092	0.092	0.0273	0.0268	0.0268	0.0268	0.0268	0.0568	0.0588	0.0588	0.0588	0.0588	0.0588	0.0588	0.0588	0.0588	0.0588
TOP	0	0.01	0.006	0.006	0.006	0.006	0.0016	0.0028	0.0028	0.0033	0.0063	0.003	0.0044	0.0044	0.0044	0.0044	0.0044	0.0044	0.0044	0.0044	0.0044
TP	0.01	0.01	0.01	0.01	0.01	0.01	0.0022	0.0034	0.0034	0.0039	0.0069	0.0036	0.005	0.005	0.005	0.005	0.005	0.005	0.005	0.005	0.005
TSS	1	1	1	1	1	1	1.5	2.4	2.4	2.4	2.4	2.4	2.4	2.4	2.4	2.4	2.4	2.4	2.4	2.4	2.4
VSS							1.98	1.98	1.98	0.9	0.9	0.9	0.9	0.9	0.9	0.9	0.9	0.9	0.9	0.9	0.9

Table 3 Potomac Detection Limits

LE2.3 and Mainstem Detection Limits																					
Censoris to 1/2 DL Red Boldface shows when DL changed																					
Calculated Values																					
parameter	CBL	CBL	CBL	CBL	CBL	CBL	CBL	CBL	CBL	CBL	CBL	CBL	CBL	CBL	CBL	CBL	CBL	CBL	CBL		
	1/1/85-2/28/85	3/1/85-5/15/85	5/16/85-9/30/86	10/1/86-9/3/187	10/1/87-9/19/88	9/20/88-12/3/189	1/1/00-12/3/103	1/1/04-12/3/105	1/1/06-12/3/106	1/1/07-12/3/107	1/1/08-12/3/108	1/1/09-12/3/109	1/1/10-12/3/110	1/1/11-12/3/111	1/1/12-12/3/112	1/1/13-12/3/113	1/1/14-12/3/115	1/1/16-12/3/116	1/1/17-12/3/117		
CHLA	DHMH did Chlorophylls until December 2008; no DL were determined											0.62	0.62	0.62	0.62	0.62	0.62	0.62	0.62	0.62	0.62
DIN	0.08	0.0039	0.0039	0.0039	0.0032	0.0032	0.0037	0.0037	0.0037	0.0037	0.0037	0.0067	0.0067	0.0017	0.0017	0.0017	0.0017	0.0017	0.0017		
DOC	1	1	0.5	0.5	0.5	0.24	0.24	0.15	0.15	0.24	0.24	0.24	0.24	0.24	0.24	0.24	0.24	0.24	0.24		
DON	0.255	0.3702	0.0261	0.1952	0.0168	0.0168	0.0163	0.0163	0.0163	0.0163	0.0463	0.0433	0.0433	0.0483	0.0483	0.0483	0.0483	0.0483	0.0483		
DOP	0.005	0.0034	0.0034	0.0104	0.0004	0.0004	0.0004	0.0004	0.0009	0.0009	0.0009	0.0009	0.0009	0.0009	0.0009	0.0009	0.0009	0.0009	0.0009		
NH4	0.04	0.003	0.003	0.003	0.003	0.003	0.003	0.003	0.003	0.003	0.003	0.006	0.006	0.001	0.001	0.001	0.001	0.001	0.001		
NO2	0.01	0.0005	0.0005	0.0005	0.0002	0.0002	0.0002	0.0002	0.0002	0.0002	0.0006	0.0006	0.0001	0.0006	0.0002	0.0007	0.0007	0.0007	0.0007		
NO3	0.04	0.0009	0.0009	0.0009	0.0002	0.0002	0.0007	0.0007	0.0007	0.0007	0.0007	0.0007	0.0007	0.0007	0.0007	0.0007	0.0007	0.0007	0.0007		
PC	0	0	0.001	0.5	0.001	0.0633	0.0633	0.0633	0.0759	0.0633	0.0633	0.0633	0.0633	0.0633	0.0633	0.0633	0.0633	0.0633	0.0633		
PHEO	DHMH did Pheopigments until December 2008; no DL were determined											0.74	0.74	0.74	0.74	0.74	0.74	0.74	0.74	0.74	0.74
PN	0.068**	0.068**	0.001	0	0.001	0.0105	0.0105	0.0105	0.0105	0.0105	0.0105	0.0105	0.0105	0.0105	0.0105	0.0105	0.0105	0.0105	0.0105		
PO4	0.007	0.0016	0.0016	0.0016	0.0006	0.0006	0.0006	0.0006	0.0006	0.0006	0.0006	0.0006	0.0006	0.0006	0.0006	0.0006	0.0006	0.0006	0.0006		
PP	0	0	0.0013	0	0.0012	0.0012	0.0024	0.0024	0.0024	0.0054	0.0021	0.0021	0.0021	0.0021	0.0021	0.0021	0.0021	0.0021	0.0021		
SI	0.1	0.012	0.012	0.012	0.01	0.01	0.01	0.01	0.01	0.08	0.01	0.01	0.01	0.01	0.06	0.0022	0.01	0.01	0.0536		
TDN	0.335	0.3741	0.03	0.1991	0.02	0.02	0.02	0.02	0.02	0.02	0.05	0.05	0.05	0.05	0.05	0.05	0.05	0.05	0.05		
TDP	0.012	0.005	0.005	0.012	0.001	0.001	0.001	0.001	0.0015	0.0015	0.0015	0.0015	0.0015	0.0015	0.0015	0.0015	0.0015	0.0015	0.0015		
TKNF	0.375	0.375		0.2																	
TKNW	0.443	0.443		0.2																	
TN	0.483	0.4439	0.031	0.2009	0.021	0.0305	0.0305	0.0305	0.0305	0.0305	0.0605	0.0605	0.0605	0.0605	0.0605	0.0605	0.0605	0.0605	0.0605		
TOC	1	1	0.501	1	0.501	0.3033	0.3033	0.2133	0.2259	0.3033	0.3033	0.3033	0.3033	0.3033	0.3033	0.3033	0.3033	0.3033	0.3033		
TON	0.403	0.44	0.0271	0.197	0.0178	0.0273	0.0268	0.0268	0.0268	0.0268	0.0568	0.0538	0.0538	0.0588	0.0588	0.0588	0.0588	0.0588	0.0588		
TOP	0.005	0.0034	0.0047	0.0104	0.0016	0.0016	0.0028	0.0028	0.0033	0.0063	0.003	0.003	0.003	0.003	0.003	0.003	0.003	0.003	0.0044		
TP	0.012	0.005	0.0063	0.012	0.0022	0.0022	0.0034	0.0034	0.0039	0.0069	0.0036	0.0036	0.0036	0.0036	0.0036	0.0036	0.0036	0.0036	0.005		
TSS	4	4	1	1	1.98	1.5	2.4	2.4	2.4	2.4	2.4	2.4	2.4	2.4	2.4	2.4	2.4	2.4	2.4		
VSS						1.98	1.98	1.98	0.9	0.9	0.9	0.9	0.9	0.9	0.9	0.9	0.9	0.9	0.9		

NOTES
 IN 1985 DATA, there was a salinity-related matrix problem with TKNW and TKNF analysis;
 Peter Bergstrom did an analysis and devised a correction factor that effects the DL; worst case DL for TKNW is 0.443 and TKNF is 0.375

Table 4 LE2.3 and Mainstem Detection Limits

NOTE: Due to logistical considerations, sample for the Tributaries station LE2.3 are collected during Mainstem cruises.

CBSeg	Station	1985	1986	1987	1988	1989	1990	1991	1992	1993	1994	1995	1996	1997	1998	1999	2000	2001	2002	2003	2004	2005	2006	2007	2008	2009	2010	2011	2012	2013	2014	2015	2016		
CBTF1	CB1.1																		x	x	x	x	x	x	x		x	x	x	x	x	x			
CBTF1	CB2.1																		x	x	x	x	x	x	x	x		x	x	x	x	x	x		
CB2OH	CB2.2																		x	x	x	x	x	x	x	x		x	x	x	x	x	x		
CB2OH	CB3.1																		x	x	x	x	x	x	x	x		x	x	x	x	x	x		
CB3MH	CB3.2																		x	x	x	x	x	x	x	x		x	x	x	x	x	x		
CB3MH	CB3.3C																		x	x	x	x	x	x	x	x		x	x	x	x	x	x		
CB3MH	CB3.3E																		x	x	x	x	x	x	x	x		x	x	x	x	x	x		
CB3MH	CB3.3W																		x	x	x	x	x	x	x	x		x	x	x	x	x	x		
CB4MH	CB4.1C																		x	x	x	x	x	x	x	x		x	x	x	x	x	x		
CB4MH	CB4.1E																		x	x	x	x	x	x	x	x		x	x	x	x	x	x		
CB4MH	CB4.1W																		x	x	x	x	x	x	x	x		x	x	x	x	x	x		
CB4MH	CB4.2C																		x	x	x	x	x	x	x	x		x	x	x	x	x	x		
CB4MH	CB4.2E																		x	x	x	x	x	x	x	x		x	x	x	x	x	x		
CB4MH	CB4.2W																		x	x	x	x	x	x	x	x		x	x	x	x	x	x		
CB4MH	CB4.3C																		x	x	x	x	x	x	x	x		x	x	x	x	x	x		
CB4MH	CB4.3E																		x	x	x	x	x	x	x	x		x	x	x	x	x	x		
CB4MH	CB4.3W																		x	x	x	x	x	x	x	x		x	x	x	x	x	x		
CB4MH	CB4.4																		x	x	x	x	x	x	x	x		x	x	x	x	x	x		
CB5MH	CB5.1																		x	x	x	x	x	x	x	x		x	x	x	x	x	x		
CB5MH	CB5.2																		x	x	x	x	x	x	x	x		x	x	x	x	x	x		
CB5MH	CB5.3																		x	x	x	x	x	x	x	x		x	x	x	x	x	x		
PAXMH	LE2.3																		x	x	x	x	x	x	x	x		x	x	x	x	x	x		
PAXMH	CB5.1W	x	x	x	x	x	x	x	x	x	x	x	x	x	x	x																			
CHOOH	ET5.1																		x	x	x	x	x	x	x	x									
CHOMH2	ET5.2																		x	x	x	x	x	x	x	x									
PAXMH	LE1.1	x	x	x	x	x	x	x	x	x	x	x	x	x	x	x			x	x	x	x	x	x	x										
PAXMH	LE1.2	x	x	x	x	x	x	x	x	x	x	x	x	x	x	x																			
PAXMH	LE1.3	x	x	x	x	x	x	x	x	x	x	x	x	x	x	x																			
PAXMH	LE1.4	x	x	x	x	x	x	x	x	x	x	x	x	x	x	x																			
PAXMH	LE2.2																		x	x	x	x	x	x	x	x									
PAXMH	RET1.1	x	x	x	x	x	x	x	x	x	x	x	x	x	x	x																			
POTOH	RET2.2																		x	x	x	x	x	x	x	x									
PAXTF	TF1.0	x				x																													
WRBTF	TF1.2	x																																	
PAXTF	TF1.3	x	x																																
PAXTF	TF1.4	x																																	
PAXTF	TF1.5	x	x	x	x	x	x	x	x	x	x	x	x	x	x	x			x	x	x	x	x	x	x	x									
PAXOH	TF1.6	x	x	x	x	x	x	x	x	x	x	x	x	x	x	x																			
PAXOH	TF1.7	x	x	x	x	x	x	x	x	x	x	x	x	x	x	x			x	x	x	x	x	x	x	x									
POTTF	TF2.3																		x	x	x	x	x	x	x	x									
PATMH	WT5.1																		x	x	x	x	x	x	x	x									
WBRTF	WX0001																																		
CB5MH	XCG8613	x	x	x	x	x	x	x	x																										

Table 5 Light Attenuation – Mainstem and Patuxent River Sampling Sites and Dates

Waterbody	Station	1985	1986	1987	1988	1989	1990	1991	1992	1993	1994	1995	1996	1997	1998	1999	2000	2001	2002	2003	2004	2005	2006	2007	2008	2009	2010	2011	2012	2013
Manokin R -Back Ck	BXK0031																			x			x		x	x	x	x	x	
Susquehanna R	CB1.0																						x	x		x			x	
Chicamcomico R	CCM0069																						x							
Eastern Bay	EE1.1								x								x	x		x			x			x				
Choptank	EE2.1										x			x	x							x	x	x		x	x			x
little Choptank	EE2.2												x				x	x	x			x		x	x					
Fishing Bay	EE3.0																			x	x	x								x
Tangier Sound	EE3.1	x	x					x					x							x	x	x								
Tangier Sound	EE3.2					x														x										
Pocomoke sound	EE3.3						x		x	x			x		x						x								x	
Northeast R	ET1.1									x					x									x		x		x		
Pocomoke R	ET10.1									x					x									x		x				x
C & D cannal	ET2.1								x			x											x							x
Bohemia R	ET2.2																				x									
Elk R	ET2.3						x					x		x												x				x
Sassafras R	ET3.1						x																			x	x			
Chester R	ET4.1								x																					
Chester R	ET4.2	x	x				x				x																	x		
Nanticoke	ET6.1														x	x	x													
Nanticoke	ET6.2																													
Wicomico R	ET7.1																							x	x	x		x		
Manokin	ET8.1		x																											
Big Annesmesex R	ET9.1					x																								
Mattawoman R - Pot	MAT0016								x		x	x		x	x															x
Mattawoman R - Pot	MAT0078								x																					
Manokin R	MNK0146																													x
Piscataway Ck - Pot	PIS0033																													
Pocomoke R - Shelltow	POK0014																													
Potomac R	RET2.1																													
Potomac R	RET2.4																													
Piscataway Ck - Pot	TF2.1									x	x																			
Dogue Ck - Pot	TF2.2																													
Potomac R	TF2.4								x																					
Transquaking R	TRQ0088																													
Transquaking R	TRQ0146																													
Transquaking R	TRQ0224																													
Wicomico R - Ferry	WIW0141																													
Bush R	WT1.1		x																											
Gunpowder R	WT2.1					x																								
Middle R	WT3.1																													
Back R	WT4.1																													
Magothy R	WT6.1																													
Severn R	WT7.1																													
South R	WT8.1																													
Rhode R	WT8.2																													
West R	WT8.3																													
Pocomoke R	XAK7810																													
Wicomico R	XCI4078																													
Nanticoke R	XDJ9007																													
Chester R	XGG8251		x																											
Corsica R	XHH4742																													

Table 6 Light Attenuation - Maryland Tributary Sites (Data not collected or submitted by Maryland Department of Natural Resources)